



NEW!

Papyrus™

See page 28



BELGARD®

PAVES THE WAY®

LIFETIME TRANSFERABLE LIMITED WARRANTY

Oldcastle® APG, Inc. ("Belgard") is proud to inform you that all of our interlocking concrete paver and retaining walls ("Products") meet and/or exceed the requirements of ASTM C-936 and ASTM C-1372. Belgard® guarantees its Products against these standards for the lifetime of the Product defined by CMHA. This guarantee does not apply to splitting, chipping or other breakage that could be caused by impact, abrasion or overloading. This warranty is transferable. The original proof of purchase is required.

This warranty is only valid if the material is installed under the guidelines of CMHA (masonryandhardscapes.org) or the Belgard Installation Guideline Manual. Improper installation voids this warranty. This warranty is for residential applications only and does not apply to commercial applications. It is recommended that the job be installed by a Belgard Authorized Contractor participant who guarantees their workmanship for a minimum of 3 years from the date of install. For warranty service, contact Belgard at 877-BELGARD. A service representative will investigate your claim within 10 business days. If the Belgard product fails to meet the specifications, Belgard will replace the defective product at no charge. Color matching cannot be guaranteed. Belgard will not be responsible for any replacement labor, consequential damages or incidental damages. This warranty gives you specific legal rights, and you may also have other rights which vary from state to state. Some states do not allow for the exclusion or limitation of incidental or consequential damages, so the above limitation or exclusion may not apply to you.

For specific information regarding warranty coverage and exclusions in regards to the Elements™ and Porcelain Paver products, please visit: Belgard.com/Warranty.

ABOUT US

At Belgard®, we take our role as industry leaders seriously. Our rigorous research and development program is centered on innovation and quality. We never take it for granted that our products are the best in the business and constantly strive to improve and take the industry to the next level. Our overarching goal is to continue to find new and exciting ways to create beautiful outdoor spaces while maintaining incredibly high standards for product quality and performance.

Since 1995, our locally made and nationally backed products have transformed thousands of residential and commercial properties across North America. With more shapes, styles and textures than any other brand, Belgard's Outdoor Living paving and wall products aren't just functional, they infuse outdoor spaces with distinctive atmosphere and style.

Every day, our network of Belgard Authorized Dealers and Contractors helps customers realize their outdoor dreams. And every year, we strive to improve our product and service offerings by dedicating more than 20,000 hours to research and development. By staying ahead of design trends, we are able to provide design-forward products that homeowners envision for their backyard spaces.

All of our outdoor products—when installed by a Belgard Authorized Contractor—are covered by a transferable lifetime limited warranty. That's just part of our commitment to lasting outdoor beauty.

PAVERS & SLABS

PAVER INSTALLATION GUIDE

- 2 Paving Systems Installation Guide
- 4 Peak Performance from Concrete Pavers

PAVERS & SLABS

- | | | | |
|----|---------------------|----|------------------------|
| 29 | Basalt™ | 55 | Mega-Arbel® Patio Slab |
| 31 | Belgian Cobble® | 57 | Mega-Bergerac® |
| 33 | Brooklyn™ | 59 | Mega-Stone™ |
| 35 | Cambridge Cobble® | 61 | Origins™ 6 |
| 39 | Dimensions™ 6 | 62 | Origins™ 12 |
| 41 | Dimensions™ 12 | 63 | Origins™ 18 |
| 44 | Dimensions™ 18 | 64 | Origins™ Accents |
| 47 | Dimensions™ Accents | 65 | Papyrus™ |
| 48 | Dublin Cobble® | 67 | Travertino |
| 51 | Holland Stone | | |

For basic paver installation information, visit CMHA at masonryandhardscapes.org
For best results blending colors, pull and install pavers from multiple pallets

PAVING SYSTEMS INSTALLATION GUIDE

INSTALL THE EDGE RESTRAINTS



Install edge restraints.

Place edge restraint on one or two sides of the area to be paved to create a square area. If installing a circle or curve, edging can be installed after pavers are placed. Anchor the edging with fasteners, approximately one fastener every 12 inches (follow instructions per edge restraint manufacturers). Before compacting pavers into the sand bed, all edging should be installed. The edging goes on the base, not on top of the sand. Remove excess sand from the edge of the paved area before installing the edging.

INSTALL THE BEDDING SAND



Install bedding sand.

Place at least two pipes of 1-inch outside diameter directly on the base. Place them 6 to 8 feet apart and parallel to each other. Spread the sand between the pipes. Use a shovel and rake to smooth it out. The sand should be moist but not wet or saturated.

Use a straight piece of wood (an 8-foot 2 x 4) to screed the sand smooth.

Pull the wood across the pipes several times until the area of sand is perfectly smooth. Remove the pipes and fill the voids with sand. Level these areas with a trowel. Don't walk on or disturb the screeded and leveled sand.

PLACE THE CONCRETE PAVERS

Start in the corner, if you have one in your design, and check to see that it is a 90-degree corner. Place a border course around the entire edge, then place the pavers in the desired pattern. See pattern and border on pages 105-114 for reference.

Continue to screed bedding sand and place pavers on the sand while maintaining consistent joint widths. String lines will help keep pavers straight.

Cut pavers as needed to fill in at the edges next to the border course. Use a diamond blade to cut the pavers.

Helpful hint for Rinn™ and Texturgard™ pavers; for optimal aesthetics leave joint space between cut pavers.



Place pavers.

INSTALL REMAINING EDGE RESTRAINTS

Installing edge restraints after pavers have been installed allows for adjustments in size of paved area to help reduce pavers needing to be cut. Based on the shape and pattern we are using, our 10- x 20-foot area may come to just under or over without having to cut pavers. When installing remainder of edging remember to remove sand from edge of pavers so edging sits on the base.



Compact pavers.

COMPACT THE PAVERS USING A PLATE COMPACTOR

Make at least two passes over all pavers, starting at the outside of the pavement, working around the edges toward the inside. Then compact back and forth like mowing grass. Remove and replace any pavers that crack from the compaction equipment. Adjust joints so they are consistent. A large screwdriver is effective for aligning paver joints.

SPREAD DRY JOINT SAND OVER THE SURFACE

Sweep some sand into the joints, then vibrate and compact it into the joints, sweeping and compacting as you go. Filling the joints with sand will take several passes with the plate compactor. After compaction, the sand in the joints might settle, especially after rainstorms. Apply extra sand to fill these joints as needed.

NOTE: Many recommend using polymeric jointing sand to fill the joints between pavers, which helps to stabilize the sand in the joints and control ants and weeds. Belgard® carries Techniseal® products such as HP NextGel Jointing sand. Make sure to follow all manufacturer recommendations in using and applying these products.

HELPFUL HINT FOR PAVER PROTECTION

Manufacturers of plate compactors recommend the use of mats or membranes between the compactor and pavers to protect the pavers from surface damage. Most plate compactor manufacturers sell accessories for this purpose.

Pavers with profiled tops, non-tumbled pavers, and Rinn™ and Texturgard™ paver surfaces are more susceptible to damage from plate compactors. We recommend that you always protect the pavers with any of the following materials between the paver and the plate compactor.

- Cardboard
- Thin carpeting
- Luan plywood
- Urethane rubber mat



PEAK PERFORMANCE FROM CONCRETE PAVERS

Quality concrete pavers create a surface that can last for generations when placed on a well-prepared base. They need practically no maintenance when installed to ICPI guidelines. This guide will help you get the most value from your concrete paver installation.

JOINT SAND



During the course of normal use, the sand-filled joints receive dust from traffic on the pavement. This dust settles into the top of the joints, helping to hold the sand in place. Installations exposed to driving winds or runoff, however, may lose some joint sand that can be

simply replenished with dry sand. Stabilized sand can be used instead of mason sand to reduce joint sand loss. Sealers can also help hold the sand in the joints. These are applied over the entire paver surface as a liquid and allowed to soak and cure in the joints. Ask your concrete paver manufacturer or distributor about these products and their application.

PREVENTING WEEDS AND ANTS

Weeds can germinate between pavers from windblown seeds lodged in the joints. They don't grow from the bedding sand, base or soil. Weeds can be removed by hand or with herbicides. Take care in using herbicides to not damage adjacent vegetated areas. Use biodegradable products that won't damage other vegetation or pollute water supplies when washed from the pavement surface. Besides stabilizing the joint sand, sealers can prevent seeds from germinating and discourage ants from entering.



SNOW AND ICE REMOVAL

Concrete pavers offer outstanding freeze-thaw resistance. They can resist damage from de-icing salts better than most pavement surfaces. Snow and ice are removed with shovels or plows like any other pavement. Electric or liquid snow-melting systems work well under concrete pavers, eliminating plowing and reducing slip hazards.



EFFLORESCENCE

Efflorescence is a white haze that may appear on the surface of pavers sometime after installation. It forms as a result of a natural chemical reaction that occurs

when the lime or water soluble calcium oxide, produced by the cement contained in the pavers, reacts with water. When the water enters the microscopic capillaries in the pavers, calcium hydroxide is formed. The calcium hydroxide rises to the surface of the paver, reacts with the carbon dioxide in the air, and forms a white haze of calcium carbonate when the moisture evaporates from the surface. The appearance of efflorescence stops when there isn't any more calcium hydroxide available to move to the surface. This process sometimes can take several months.



Pavers with efflorescence



Pavers after cleaning

Efflorescence does not damage pavers. However, it can be unappealing. The white haze may give the impression that the paver color is fading but this is not the case. Efflorescence may occur randomly or be concentrated in certain areas. Dark colored pavers show efflorescence more than lighter-colored ones. If efflorescence does occur, it can be removed with cleaners specially made for concrete pavers. Careless or improper cleaning can result in damage and discoloration to the concrete paver surfaces. Contact your Belgard sales representative for further information on efflorescence cleaners.

COLOR AND WEAR

Color in concrete pavers is achieved by adding pigment to the concrete mix during production. The cement in the concrete mix holds the pigments in place. They are very stable, showing little change in their properties over time. As the paver wears from traffic or weather, the cement and pigment particles gradually erode causing a color change over time. Like all pavements, concrete pavers receive dirt from foot or tire traffic which also changes the surface color. One way to moderate the rate of color change is by cleaning and sealing the surface of the concrete pavers. Besides enhancing their color, sealers can prevent dirt from lodging in the surface.



Sealed

Unsealed

SETTLEMENT AND UTILITY REPAIRS

Settlement is often caused by inadequate soil or base compaction. Other factors can be water in the base or soil, too thick a layer of bedding sand, or washed out bedding and joint sand. Loose or inadequate edge restraints cause pavers to move apart and can also contribute to settlement. If the base or soil has settled and is stable, remove the pavers and bedding sand, place and compact additional base material to the correct level, then add bedding sand. The removed pavers can then be reinstated with no wasted paving materials or unsightly patches. Concrete pavers can be removed for access to underground utilities, and reinstated after repairs. When utility repairs are complete, fill the trench with base material and compact it. Remove about 18 in. (0.5 m) of pavers on either side of the opening, level the bedding sand and replenish as necessary. Reinstall the pavers, compact, fill the joints with sand and compact the surface again, filling joints as needed.



REMOVING OIL STAINS

Concrete pavers aren't damaged by oil leaking from cars, but the stains can be difficult to remove. Stains should be treated as soon as possible since the longer they remain on the surface, the deeper they penetrate making removal harder. Wipe excess oil from the surface as soon as possible and apply liquid detergent. Allow it to soak for several minutes. Then scrub and wash the pavers with hot water. Several treatments may be necessary for particularly stubborn stains. Cleaners specially made for removing oil stains from concrete pavers are available and yield good results. In some cases, it may be simpler to replace the stained pavers with new ones. Cleaning and sealing concrete pavers early in their life can make removing stains easier since sealers prevent stains from soaking into the surface.



PAVER ESTIMATING FORMULA

AGGREGATE BASE ESTIMATING FORMULA

For this example we are using a 10' x 15' Rectangular patio with a 6" base.

1. Calculate the square footage of the job.
2. Divide the square footage by 200.
(1 ton of loose aggregate covers 200 SqFt at 1" thick)
3. Multiply by the thickness of the base in inches.
4. Multiply by 1.25 to account for the compaction.
5. This gives you the number of tons of aggregate needed.

Project Example:

$15 (L) \times 10 (W) = 150 \text{ SqFt}$
 $150 \text{ SqFt} / 200 = .75 \text{ tons/inch of base}$
 $.75 \times 6 \text{ inches of base} = 4.5 \text{ tons}$
 $4.5 \text{ tons} \times 1.25 = 5.625 \text{ tons}$
5.625 Tons of Aggregate Needed

BEDDING SAND ESTIMATING FORMULA

For this example we are using a 10' x 15' Rectangular patio with a 6" base.

1. Calculate the square footage of the job.
2. Divide the square footage by 200.
(1 ton of loose aggregate covers 200 SqFt at 1" thick)
3. Multiply by the thickness of the base in inches.
4. Multiply by 1.25 to account for the compaction.
5. This gives you the number of tons of bedding sand needed.

Project Example:

$15 (L) \times 10 (W) = 150 \text{ SqFt}$
 $150 \text{ SqFt} / 200 = .75 \text{ tons/inch of base}$
 $.75 \times 1 \text{ inches of sand} = .75 \text{ tons}$
 $.75 \text{ tons} \times 1.25 = .9375 \text{ tons}$
.9375 Tons of Bedding Sand Needed

SOLDIER COURSE ESTIMATING FORMULA

For this example we are using a 10' x 15' Rectangular patio with Holland Stone for the Soldier course.

1. Add up the linear footage of the job.
2. Multiply the linear footage by 12 to convert to inches.
3. Divide by the width of the paving stone being used for the soldier course to get the number of stones needed.
4. Multiply the number of stones by the SqFt/Unit.
5. This gives you the amount of square footage needed.

Project Example:

$15(L1) + 10(L2) + 15(L3) + 10(L4) = 50 \text{ LnFt}$
 $50 \text{ LnFt} \times 12 = 600$
 $600 / 4 = 150$
 $150 \text{ units} \times .215 = 32.25 \text{ SqFt}$
32.25 SqFt Needed

SAILOR COURSE ESTIMATING FORMULA

For this example we are using a 10' x 15' Rectangular patio with Holland Stone for the Sailor course.

1. Add up the linear footage of the job.
2. Multiply the linear footage by 12 to convert to inches.
3. Divide by the length of the paving stone being used for the sailor course to get the number of stones needed.
4. Multiply the number of stones by the SqFt/Unit.
5. This gives you the amount of square footage needed.

Project Example:

$15(L1) + 10(L2) + 15(L3) + 10(L4) = 50 \text{ LnFt}$
 $50 \text{ LnFt} \times 12 = 600$
 $600 / 8 = 75$
 $75 \text{ units} \times .215 = 16.125 \text{ SqFt}$
16.125 SqFt Needed

INTERLOCKING CONCRETE PAVEMENT

Interlocking concrete pavements (ICP) are flexible pavements designed to spread loads imposed on a small area of the pavement surface through a base layer (or series of layers or sub-bases) to a large enough area of the soil subgrade that the soil subgrade can support the load without rutting.

A 1,000 lb. wheel with a footprint of 40-SQIN exerts a load on the pavement surface of 3,600 lbs./SQFT. With proper design and construction, a flexible pavement can expand the footprint to 8-SQFT on the soil subgrade, thus reducing the load on the subgrade to only 125 lbs./SQFT. In a flexible pavement, the pavement surface and base have the ability to move slightly or flex under load then recover when the load is removed.

The unique aspect of interlocking concrete pavements is that the pavers interlock to help spread the imposed loads. There are three kinds of interlock: vertical, rotational and horizontal.

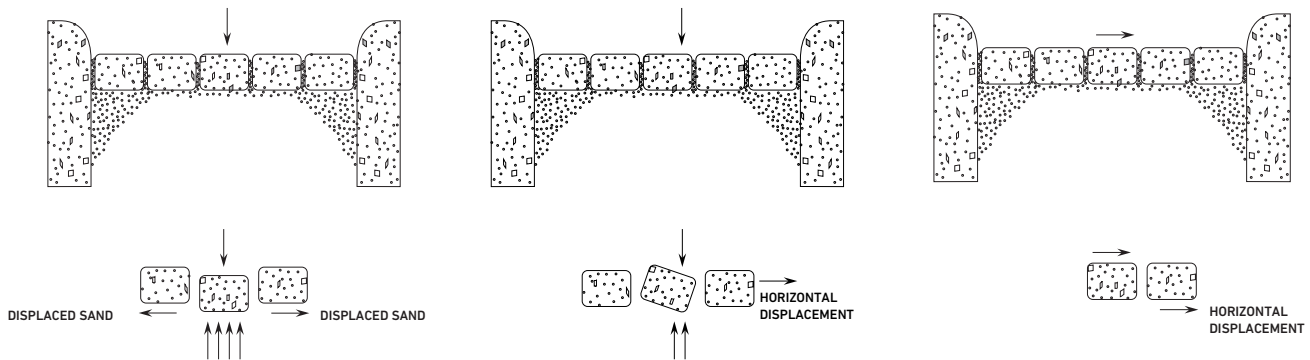

VERTICAL INTERLOCK

This is achieved by the shear transfer of loads to surrounding units through the sand in the joints. This shear transfer also prevents one paver from moving vertically in relationship to its neighbor(s).

ROTATIONAL INTERLOCK

This is achieved through use of the proper paver thickness in relationship to load and use and by a perimeter edge restraint. A slight crown constructed into the pavement will increase rotational interlock and the load bearing capacity of the pavement.

HORIZONTAL INTERLOCK

This is achieved through the use of laying patterns that minimize the length of uninterrupted joint lines and disperse forces from braking, turning and accelerating vehicles. Certain geometrically interlocking paver shapes enhance horizontal interlock. Herringbone laying patterns provide the most effective horizontal interlock and should always be used in vehicular applications.

In summary, the contractor achieves vertical, rotational and horizontal interlock by the interaction of these factors:

JOINT WIDTHS - consistent joint widths of approximately 1/8-in

JOINT SAND - properly selected joint sand

PAVER THICKNESS - 60mm (2 $\frac{3}{8}$ -in) for pedestrian and some residential driveways

80mm (3 $\frac{1}{8}$ -in) for heavy and industrial vehicle applications

EDGE RESTRAINT - non-moving fixed edge restraint

LAYING PATTERN - minimize length of uninterrupted joint lines in all directions. The most commonly used pattern is Herringbone.

See product pages for other acceptable pattern options.

PAVER SHAPE - shapes which allow Herringbone type laying patterns and which geometrically interlock on two or more sides with each other

CROWN - slight crown in pavement cross section

COMPARISON OF PAVEMENT SYSTEMS

Interlocking Concrete Pavements:

- Flex without cracking.
- Do not require expansion joints.
- Resistant to spilled fuel and oil.
- Resistant to freeze/thaw damage.
- Resistant to de-icing compounds.
- Virtually unlimited combination of solid and blended colors, shapes and laying patterns.
- May be used immediately upon completion of installation.
- May be disassembled to repair subgrade or underground services then reinstalled with no unsightly patch.
- Skid and slip resistant surface.
- Cooler surface.
- Easy to work to grade transitions.
- Long design life.
- Low life cycle costs.
- Virtually maintenance free.

Asphalt:

- Flexible, but more apt to crack than ICP.
- Cracks from evaporation of essential oils.
- Dissolved by spilled fuels or oil.
- Limited colors.
- Patches and repairs obvious.
- Relatively short design life.
- Must be sealed on a regular basis.
- Loses strength with increase in temperature.
- Installation requires special equipment.

Poured-in-Place Concrete:

- Cracks from load flexing and from thermal expansion and contraction.
- Difficult to effectively repair and repairs are obvious.
- Less resistant to de-icing compounds than ICP.
- Design life longer than asphalt, less than ICP.
- Must cure before use.
- Subject to environment during curing.
- Needs expansion joints.
- Stamped concrete typically colored only on the top.

COMPONENTS OF THE ICP SYSTEM

Other flexible pavement systems include asphalt (bituminous) pavements. These pavements are designed and function in a similar manner to ICP. Stamped asphalt is in this category.

Rigid pavements are designed to bridge or span soft areas in the soil subgrade. Rigid pavements include poured-in-place Portland cement concrete, regular poured concrete, exposed aggregate concrete, stamped or imprinted concrete and decorative pavements mortared or adhered to a concrete surface or a bituminous layer overlying concrete.

The eight components of the ICP system are:

SUBGRADE

The in-place soil on which the pavement will be constructed. The characteristics of the subgrade soil have a major effect on the design and performance of the pavement and can also impact construction time and cost. The gradation, or distribution of the various size particles making up the subgrade soil, greatly influences the ability of the subgrade to support loads. Soils range from coarse grained sands to silts and clays which contain the smallest particles. The smaller the particle size, the less strength the subgrade will have. Clay soils are, in general, the weakest. The three most common methods used to rate or classify soils are discussed in Appendix A.

A simple way to quickly classify soils in the field is by visual appearance and feel. If coarse grains can be seen and the soil feels gritty when rubbed between the fingers, then it is a sandy soil. If the grains cannot be seen with the naked eye and it feels smooth, then it is a silt or clay. Don't be fooled by the apparent solidity of clay soils, they shift under loads.

A primary factor in the performance of soil under pavement is its ability to hold water. The higher the water holding ability, the worse the soil generally performs as a foundation for pavement. Some easy ways for the contractor to make a quick field identification are described below.

Patty Test - Evaluating the water holding capacity of a soil:

- Mix the soil with enough water to make a putty-like consistency.
- Form the sample into a patty, let it dry completely.
- The greater the effort required to break the patty with fingers, the greater the plasticity, or ability to hold water. In other words, the more water the soil can hold, the less suitable it is under pavement.
- High dry-strength is a characteristic of clays. Silts and silty sands will break easily.

Shake Test - The dilatancy test, or a test for reaction to shaking:

- Mix a tablespoon (15 ml.) of water with the soil sample in the hand. The sample should be soft but not sticky.
- Shake or jolt the sample in a closed palm of the hand a few times.
- If water comes to the surface, the soil is fine sand.
- If none or a little comes to the surface, it is silt or clay.
- If squeezing the soil between the fingers causes the moisture to disappear, the soil is sandy.
- If moisture does not readily disappear, then the soil is silty.
- If moisture does not disappear at all, the soil is clay.

Snake Test - Evaluating the thread toughness for clay content:

- A small sample of soil is moistened to the point where it is soft but not muddy or sticky.
- It is rolled into a thread or "snake" between the hands.
- The longer the thread, and the more it can be rolled without breaking, the higher the clay content.
- The subgrade must be compacted to at least 95 percent of Standard Proctor Density before the base is installed.

GEO TEXTILE

Sometimes called filter cloth or soil separation fabric. A layer of woven or non-woven fabric placed between the subgrade and base to prevent the two layers from mixing under repetitive traffic loading. A Geotextile should be used if the subgrade is clay or is poorly drained and apt to stay wet for extended periods. A greater amount of base does not substitute for a Geotextile fabric in poor soil conditions. Check with your Authorized Belgard Distributor for the proper Geotextile.

SUB-BASE

A compacted layer or layers of specified material placed on the subgrade to support the base. Sub-bases are used primarily in heavy duty pavements or in areas with poor subgrade material.

BASE

A layer of specified material of a designed thickness placed on the subgrade (or sub-base) to support the pavement surface. In an ICP, the most common base material is a compacted layer of Dense Graded Aggregate (DGA). Do not use stone dust or screenings.

The chart at right serves as a guideline for base construction for driveways, patios, walks and pool decks. In very cold winter climates, or in soils that retain excess water, thickness may be increased by two to six inches.

Check with your Authorized Belgard Distributor for the proper DGA for your area.



APPLICATION	BASE THICKNESS
Driveways	6 in. - 8 in.*
Patios	4 in. - 6 in.
Walkways	4 in. - 6 in.
Pool Decks	4 in. - 6 in.

*Add 2 in. for low, wet, clay and silt soils.

EDGE RESTRAINT

A specially designed edging, curb, building or other stationary object that contains the bedding sand and pavers so they do not spread and lose interlock. There are many plastic, aluminum and steel edge restraints specifically designed for use with unit pavers.

In addition to the specially designed edge restraints, properly installed troweled concrete, poured-in-place concrete structures and treated timbers may be used. Troweled concrete is especially applicable in areas of sandy soil which does not allow spiked edge restraints to stay in place. **Check with your Authorized Belgard Distributor for a list of products available.**

SAND SETTING BED

A layer of coarse, clean sand loose screeded to a thickness of one (1) inch over the base layer for bedding the pavers. When the pavers are compacted into the sand bedding layer, some sand enters the joints between the pavers from the bottom and begins the process of vertical interlock. The sand layer also allows the compaction process to achieve a smooth pavement surface, compensating for any minor differences in paver thickness. Do not compact the sand setting bed before setting pavers.

The bedding sand may be natural or man made but should conform to the requirements of ASTM C33. Do not use mason sand, stone dust or screenings. The gradation of ASTM C33 is included in Appendix A.

INTERLOCKING CONCRETE PAVERS

A concrete paver unit meeting requirements of ASTM C936-96. The pavers "shall be capable of being lifted and placed with one hand, and shall have an exposed face (top surface) area less than or equal to 100.75 sq. in. The aspect ratio (that is, overall length divided by thickness) shall be equal to or less than 4. A 12 in. x 12 in. paver does not qualify because it has a top surface area greater than 100.75 sq. in.

Other requirements of concrete pavers are:

- Average compressive strength not less than 8,000 lbs. per sq. in.
- Resistance to freezing and thawing. Less than 5 percent absorption
- Dimensional tolerance

These requirements of ASTM C936 insure a uniform durable paver unit.

Concrete pavers are manufactured in two thicknesses. Pavers 2-3/8 in. (60mm.) thick are used for pedestrian applications such as walkways, patios, plazas and pool decks. They may also be used in residential driveways. Pavers 3-1/8 in. (80mm.) thick are used in vehicular traffic and heavy duty applications.

JOINT SAND

The sand used to fill the joint spaces between pavers to achieve vertical interlock. This sand must be clean, sharp, durable and well graded. Generally, it is best to use the same washed concrete sand (ASTM C33) used for the bedding layer as the joint sand. This is especially important in vehicular trafficked ICP. The sand should be spread, allowed to dry, then swept into the joints. The process can be accelerated if after the initial sweeping, a plate compactor is run over the pavement while

the sweeping is continued. Finer sand conforming to ASTM C144 specifications may be used in pedestrian and residential driveway applications. Bagged "all-purpose" sand may be used in pedestrian ICP but masonry sand, box or play sand as well as stone dust or screenings should not be used. The recommended gradation for the joint sand may be found in Appendix A.

Be sure the joints are filled with sand. In some cases it may be necessary to re-sand the job in two to three weeks.

SUMMARY:

The components of an ICP are:

- Subgrade
- Geotextile (if needed)
- Sub-Base (if needed)
- Base
- Bedding Sand
- Edge Restraint
- Interlocking Concrete Pavers
- Joint Sand

Detailed information on the materials used is contained in Appendix A.

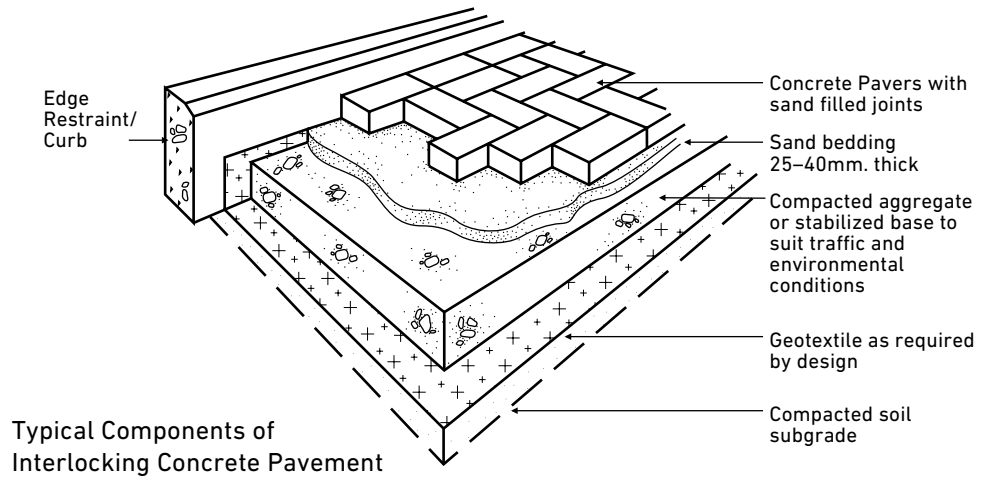

TOOLS, SUPPLIES AND EQUIPMENT

Most of the tools, supplies and equipment needed to install ICP are common to contractors involved in residential site work. The heavier and more expensive equipment may be easily rented if the work volume justifies the purchase. Some tools have been designed especially to facilitate the installation of ICP and are available through your Authorized Belgard Distributor.

QTY		QTY	
1	Folding 6 ft. ruler	1	Steel Garden Rake
1	4 ft. Level	1	Shovel(s) Round Point
2	16 ft. Tapes	1	Push Broom
1	Torpedo Level	1	Slim Jim Pry Bar
1	100 ft. Tape	1	Contractor's Wheel Barrow
1	Line Level	1	36 in. Crow Bar
1	Steel or Aluminum Carpenter Square	1	Screed Board (Magnesium) or 10 ft.-12 ft. wood 2x4's
1	Mason Trowel - Rectangular	2	Large Flat Blade Screw Drivers
1	Claw Hammer	6	Screed Rails 3/4 in. ID Steel Pipe or 1 in. Square Steel tubing approximately 10 ft. long (a couple of 4 ft. pieces are handy)
1	Mason Trowel - Pointed	1	Hacksaw
1	Mason Hammer	1	Carpenter's Saw
1	Mason Wood Float	1	Plumb Bob
1	3 lb. Maul	1	Garden Hose (75 ft.-100 ft.)
1	4 in. Brickset (Mason Chisel)	1	Chalk Line
1	12 lb. Sledge Hammer	1	Hand Tamper
1	Pair Metal Snips		
1	Rubber or Deadblow Hammer		
1	Shovel(s) Square Point		

Some special tools designed specifically for the ICP industry are:

- Paver Cart - to transport full straps of pavers
- Paver Extractor - to remove installed pavers
- Dead Blow Rubber Hammer - to help adjust pavers
- Paver Scribe - to mark pavers for cutting
- Paver Adjuster - to move installed pavers to straighten lines

Personal Safety and Comfort Supplies:

- Eye Protection
- Ear Protection (muffs or plugs)
- Dust Mask (disposable)
- Steel Toed Shoes
- Gloves
- Knee Pads
- Back Support
- Finger Tape (can use duct tape)
- First Aid Kit
- Water Cooler

Expendable Supplies :

- Mason String Line
- Chalk for Chalk Line
- Marking Crayon (keel)
- Flagging Tape
- 2 ft. Wood Stakes
- Diamond Saw Blades
- Fuel & Oil
- Spray Marking Paint

Equipment:

Installation equipment may be owned or rented. The most common equipment needed is:

- Builders level or transit level with tripod and rod. Laser levels are excellent.
- Vibratory plate compactor rated minimum 5000 ft. lbs.
- Masonry saw
- Table saw, wet or dry, or a hand held cut-off saw. Either should be gasoline powered. A hand held cut-off saw is the most flexible and productive.

Heavy Equipment:

- Skid-Steer Loader capable of lifting 5000 lbs. - equipped with interchangeable bucket, forks and rotary broom
- Vibratory Roller - used for subgrade and base compaction on larger jobs
- Jumping Jack Compactor - for compacting trenches
- Backhoe - for excavation (especially demolition)
- Dump Truck - to haul excavated materials and to deliver material to job site

CONSTRUCTING THE ICP

UTILITY LOCATION

Before beginning any phase of the construction process, make sure that all underground utilities, services and structures have been located and clearly marked on the ground surface in all areas involved in the construction process including access lanes. In many areas, a single number such as Miss Utilities may be called.

Items to be located are:

- Electrical
- Sanitary sewer
- Gas
- Septic tank
- Water supply
- Telephone
- Storm sewer
- Cable TV
- Drainfield
- Irrigation piping

Double check; there may be other items particular to the job site.

SITE ACCESS

Before any demolition, delivery or construction equipment is allowed on site, make sure that there are no hazardous conditions such as overhead electric lines in the way. Plan all activities so that no damage will occur to existing pavements, structures, trees, shrubbery, gardens or other site amenities.

LAYOUT

Identify the area to be excavated and mark it on the ground with spray paint. Make sure the area to be excavated is at least 12 in. wider on all outside edges than the size of the pavement.

Place grade stakes with string lines just outside the area to be excavated, making sure that the excavation is at least 12 in. wider than the edge of pavement. Mark the elevations on the stakes so that the depth of excavation can be checked as it progresses. Use nylon mason's line and set it at the finished elevation of the pavement. Measure all excavations and base thickness from these lines. Set the initial elevations and check them at the beginning of each day with a builders level. The stakes can be moved at night by mischievous persons.

String lines set at final or finished elevations should be sloped. All lines (and final elevations of the pavement) should slope away from the house or building. The minimum recommended slope is 1.5 percent or a drop of 3/16 in. for every foot of pavement. Many pavements are sloped at 2 percent or 1/4 in. per every foot of pavement as this will better facilitate drainage. The maximum slope for comfortable walking is 7 degrees or about 12 percent. A builders level should be used to establish elevations using marks on stakes set around the area to be paved.

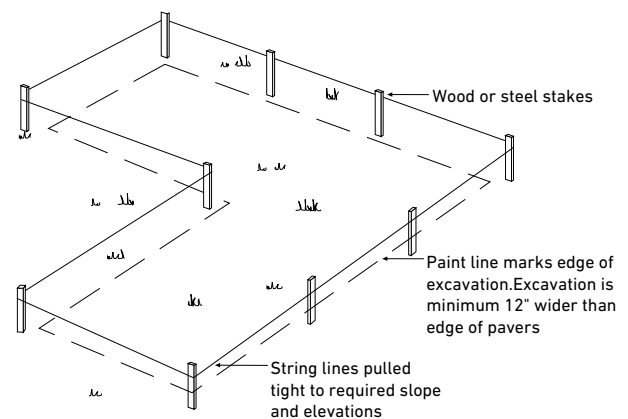

Job Layout and Staking

EXCAVATION / SUBGRADE

Make sure that the area to be excavated is at least 12 in. wider than the limits of the ICP. This provides a firm base to support the edge of the pavement and the edge restraint.

Make sure that the depth to be excavated is measured from finished pavement surface elevations and is marked on all grade stakes. The bottom of excavations, below finished pavement elevation, should equal the total thickness of the designed base, sand bed (after paver installation and compaction) and the paver being used.

Try not to disturb the subgrade below the planned excavation depth. Over excavation is costly and can cause future problems.

When all excavation is completed, compact the subgrade with a vibratory plate compactor. Make sure that compaction is thorough, uniform and complete. If soft spots are encountered, they should be removed and backfilled with the material to be used for the base. If the subgrade is too wet to compact, allow it to dry or try adding a few inches of dry base material before compacting.

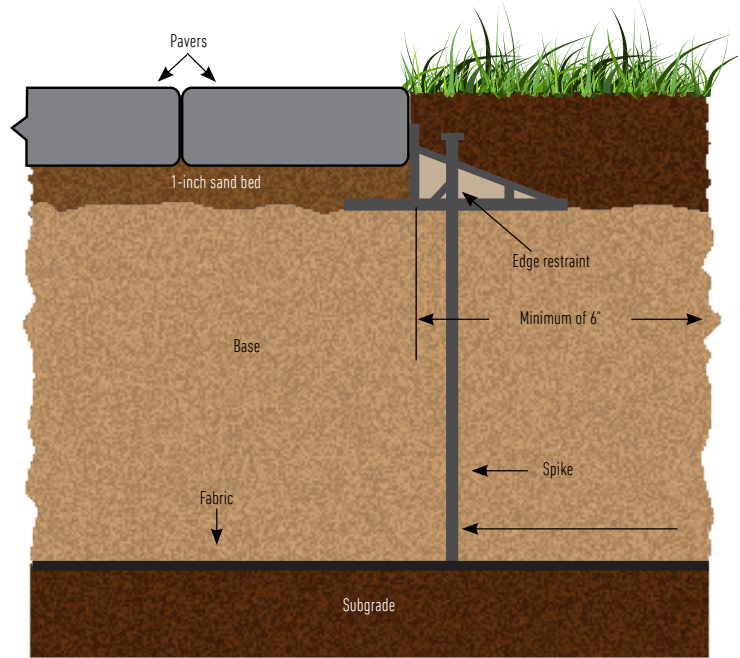

TYPICAL CROSS SECTION

EXAMPLE:

Sub-base (if any)	0-in
Base (compacted)	6-in
Sand bedding (compacted)	5/8-in
Paver thickness	2 3/8-in
Total Depth	9-in

EXCAVATION CHART

Remove existing sod and soil

PAVERS	WELL DRAINED AREA/ UNDISTURBED SOIL		POORLY DRAINED AREA/ DISTURBED SOIL		PAVER THICKNESS
	Granular base	Bedding course	Granular base	Bedding course	
PEDESTRIAN TRAFFIC, PATIOS, WALKWAYS, POOL DECKS	4" (100 MM)	1" (25 MM)	6" (150 MM)	1" (25 MM)	2 3/8" (60 MM) 2 3/4" (70 MM)
VEHICULAR TRAFFIC RESIDENTIAL DRIVEWAYS	8" (200 MM)	1" (25 MM)	12" (300 MM)	1" (25 MM)	2 3/8" (60 MM) 2 3/4" (70 MM) 3 1/8" (80 MM)
Total excavation = Granular base + bedding course + paver thickness - 1/2" (13 mm) for an uncompacted bedding thickness					

BASE

The recommended DGA base material (see Appendix A) should be spread in layers of uniform thickness then compacted. The thickness of the layer depends on the method of compaction and the planned use of the pavement. While compaction of the subgrade and base layers is key to the performance of any pavement, it is absolutely essential to pavements trafficked by vehicles. The 4 in. 6 in. base for patios, walkways and pool decks may be placed in two or three layers and compacted with a vibratory plate compactor of 5,000 ft. lbs. of force or greater. The 6 in. - 8 in. base for driveways may be placed in two lifts of 3 in. - 4 in. if a vibratory roller is used.

Place and compact the base material as recommended, making sure to keep the material lightly dampened. If free water appears on the base surface during compaction, the material is too wet and should be allowed to dry (or add a layer of dryer base material) before continuing compaction.

Be sure to thoroughly compact along edges, in corners and around structures. These are the most difficult areas to treat and the most apt to cause future settlement problems.

Do not use frozen base material and do not place base material over a frozen subgrade.

Be sure that the outside limits are at least 12 in. wider than the outside limits of the pavement.

When proper compaction of DGA has been achieved, the surface should be smooth, leave no areas into which the bedding sand can migrate. It may be necessary to fill any such areas with a finer material then recompact. The finished base surface should be flat (no more than 3/8 in. plus or minus variation under a 10 ft. straight edge) and uniformly true to grade.

Summary:

- Base must be 12 in. wider than pavement on all sides.
- Use proper base material.
- Do not place frozen base material.
- Do not place base material over frozen subgrade.
- Place and fully compact base in layers.

EDGE RESTRAINT

Edge restraints must be installed on that part of the pavement edge which is not restrained by an existing structure such as a building, concrete curb or concrete slab.

Edge restraints are typically placed before installing the bedding sand and pavers. Some edge restraints can be installed after placement of the pavers and before compaction. Troweled concrete edge restraint is installed after the pavers have been placed.

A detailed description of the various types of edge restraints is contained in Appendix A. Consult your Authorized Belgard Distributor for the edge restraint(s) recommended for your area. Also refer to ICPI Tech Spec 3 "Edge Restraints for Interlocking Concrete Pavements".

Be sure that any area where bedding or joint sand can escape through or under the edge restraint is lined with a strip of Geotextile. Loss of sand will cause eventual settlement of the pavers.

Back fill outside of edge restraint as soon as possible to prevent sand from escaping under the edge restraint.

SAND SETTING BED

Loose screed the washed concrete sand (see Appendix A) to an uniform thickness of 1 in. over the compacted base course. In no case should the sand be greater than 1-1/2 in. thick.

If the edge restraint has already been installed, the screed board may be notched to ride on the edge restraint on one or both ends. The notch should be cut to allow for the screeding of a 1 in. thick sand layer.

If the edge restraint cannot be used to carry the screed board, screed rails must be used. Screed rails

may be wood, plastic or iron pipe or square steel tubing. The rails should be sized to allow for a 1 in. thick sand bed. For example, a 3/4 in. iron pipe (3/4 in. is the inside pipe diameter) has an outside diameter of approximately 1 in.

Place the screed rails parallel to each other and close enough together to enable the screed board to be pulled along the rails without falling off. Set the top of the rails to the desired elevation below grade lines and stabilize by hand packing sand along both sides of the rail.

Place the washed concrete sand between the screed rails and rough screed with a shovel, steel rake or lute. Excess sand makes the screed board difficult to pull. Place screed board on the rails and draw forward leaving a smooth surface. Fill in and rescreed any open streaks.

When a screed rail is no longer needed, it should be carefully removed and the void filled with sand and hand floated. Do not compact the sand setting bed before laying pavers.

PAVERS

In most ICP projects, the pavers, regardless of paver shape, are laid in patterns where two sets of joints run perpendicular to each other. Radii or curves are cut into the pavement after the field pavers have been laid but not compacted. Straight joint lines not only make the finished pavement look clean and sharp but make installation much easier. If pavers shaped to geometrically interlock with each other are not laid in straight lines, they will not fit together.

To keep joint lines straight, parallel string lines or chalk lines snapped on the sand setting bed should be used. The lines should be spaced five to ten feet apart with the spacing equal to the laying modulus of the paver shape being installed. This can be determined by laying a course of pavers in the proper pattern with 1/8 in. joints and measuring the distance between at the desired line separation distance.

Procedure:

- Snap a string line on the screeded sand in the center of the area(s) to be placed.
- The line should be perpendicular to the laying face.
- Place pavers in the given laying pattern on both sides of the line.
- If additional lines are snapped, they should be parallel to each other. Check this by measuring the distances at the opposite ends of each line. They should be equal.
- If they are not parallel, they can be erased and snapped again. Parallel chalk lines snapped in bedding sand or string lines pulled above sand and pavers. Parallel string lines are also used to pave around openings in the pavement such as manholes or swimming pools.

Procedure:

- Pull perpendicular string or snap chalk lines on all four sides of the opening.
- Lay pavers on one side, then the other.
- Count the courses needed to surround the openings on each side. They should be equal in number on both sides.
- Then fill around the remaining side of the opening.
- Cut pavers to fit and fill against the edge restraint around the opening.

Plan your installation to begin along a straight line and preferably in a corner which is easily accessible. Make absolutely certain that the beginning corner is a true 90 degree angle. If the intersection of 2 sides is not a true 90 degree angle, you must establish a 90 degree starting point.

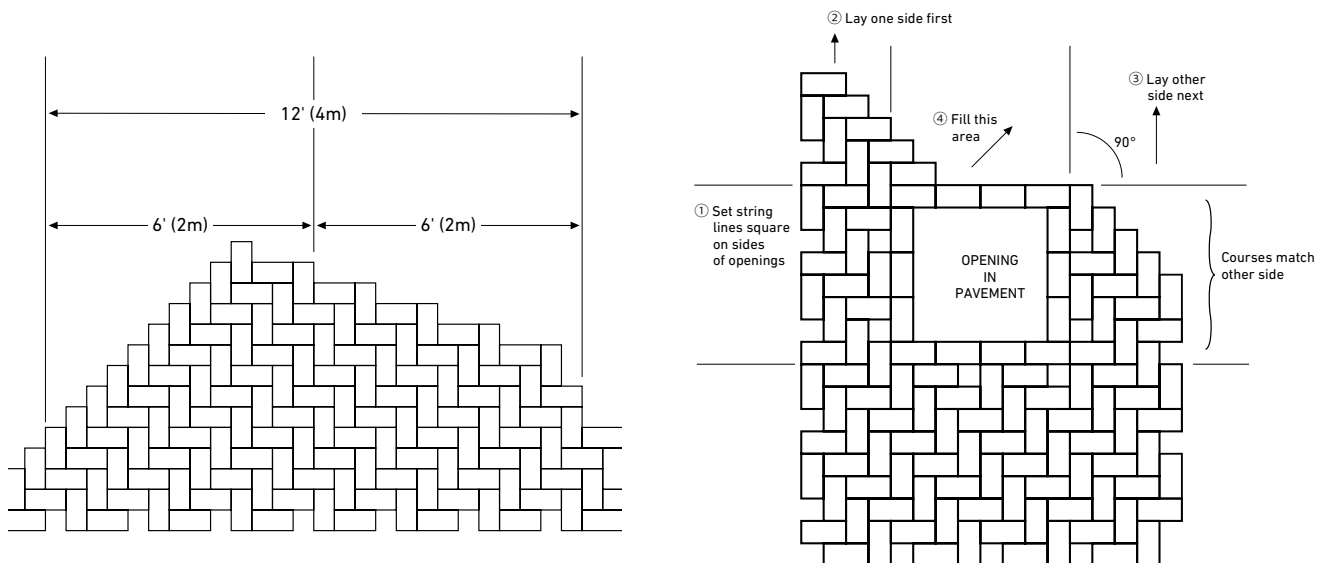

3:4:5 Triangle may be used to establish a 90 degree angle or to check existing corners:

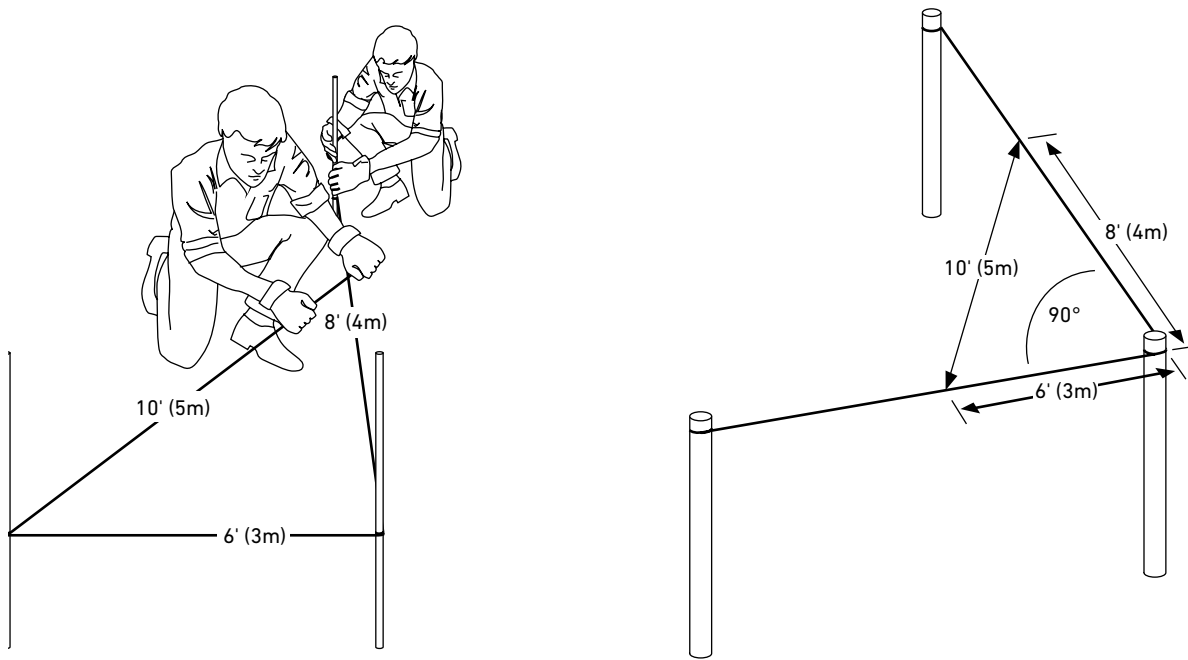

A quick way to establish a line perpendicular to an edge (no corner walls) is with the following procedure:

- Measure and mark the length of the edge, or line, from which paving will begin. The line can be 10-20 ft. (3-7m.) long. This line is where an edge restraint will be placed, or where one is already placed.
- Mark exactly the half way point on the line that was just measured. In other words, divide the line in half.
- Take one tape measure and extend it from the other end of the line at an angle toward the center. Be sure the tape extends past the middle of the line by a foot or two (0.2m.-0.6m).
- Take a second tape measure and extend it from the other end of the line at an angle toward the center.
- Overlap one tape on the other and match the length of both tapes. The same marked dimensions on each tape should be touching each other.
- Snap a line from the point where the two tape measures cross to the center of the line.
- This line is perpendicular to the line from which paving will begin.

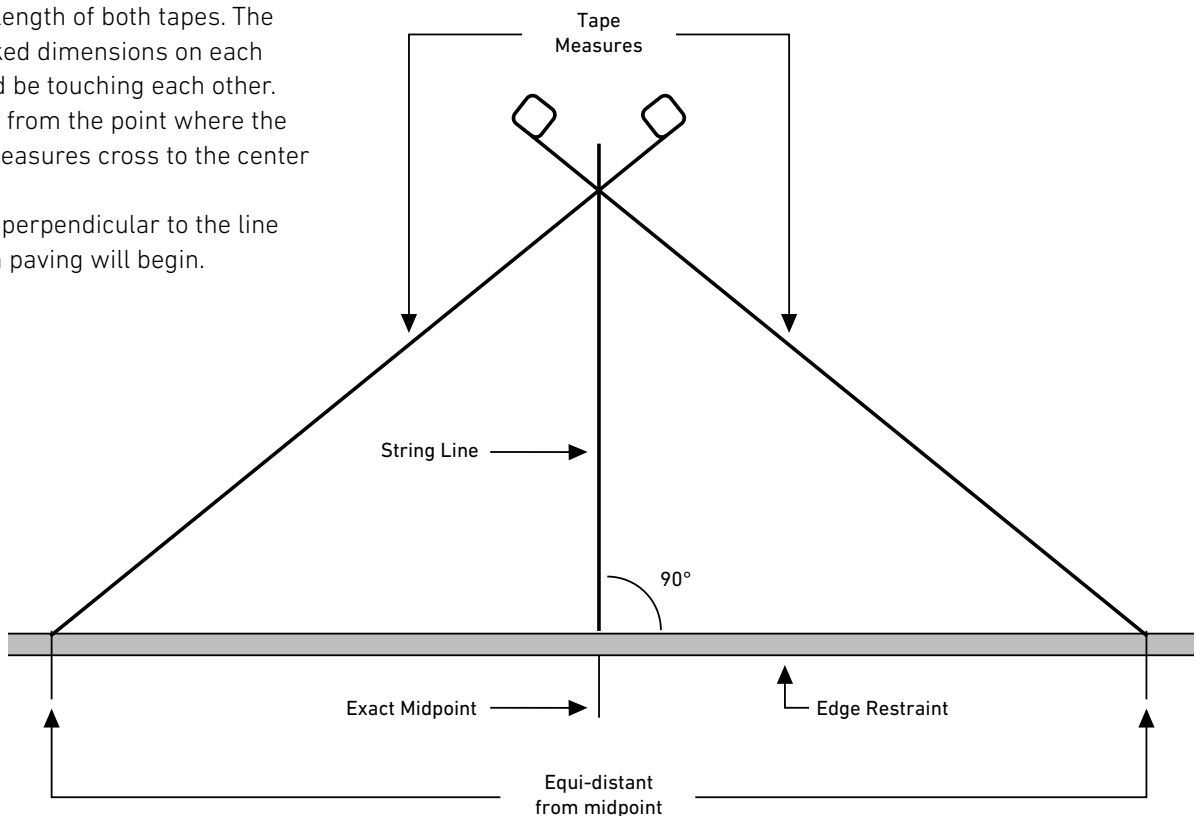

STARTING LAYING PATTERNS

Starting the first few rows of the pavement requires attention to the order of placing the pavers. The proper order for beginning herringbone patterns with a rectangular paver is illustrated below. The installation begins at a 90 degree corner.

When placing the pavers, it is important to maintain consistent joint spacing of 1/16 in. to 3/16 in. Consistent joint width of approximately 1/8 in. will spread loads (vertical interlock) better than wider joints. Consistent joint spacing will result in a neat and orderly appearance of the finished pavement.

The 1/16 in. spacer ribs molded into the sides of pavers are to ensure a minimal joint and that at least some sand can enter the joints between pavers. They are not intended to be the spacing mechanism. The best way to maintain joint consistency during paving is by the "click and drop" method.

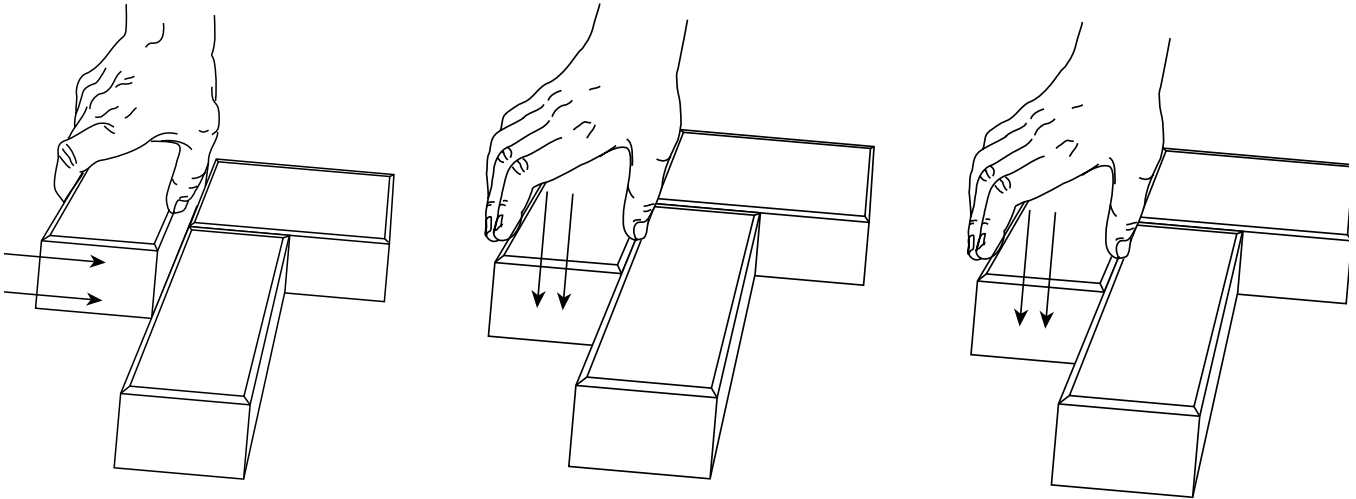

Click and Drop Procedure:

- While holding a paver, the bottom 1/4 in. to 1/2 in. should "click" firmly against the top portion of the side of the pavers already placed.
- Do not hit the previously placed pavers so hard that they move.
- Release grip, dropping the paver an inch or so directly downward. A slight pressure with fingers will ensure that the paver does not move away from those already placed.

CUTTING PAVERS

Pavers may be cut with any one of three basic pieces of equipment. They are:

- Mechanical or guillotine splitter
- Masonry saw
- Hand held cut-off saw

Mechanical or guillotine cutters are relatively inexpensive to buy but produce the least desirable results. Masonry saws may be either gasoline engine or electric motor driven. They may be hand held or mounted on a stand. Hand held cut-off saws are the most convenient and produce the best overall combination of quality and productivity.

EDGE PAVERS AND PAVER CUTTING

Especially manufactured edge units are available for some paver shapes. Check with your Authorized Belgard Dealer for availability of these units.

In most cases, pavers along the pavement edges will need to be cut. The four types of cutting equipment generally available are:

- Mechanical cutter or guillotine splitter. This equipment cuts pavers between two steel blades through hydraulic or mechanical pressure. The cutting process is quick but the cut edge tends to be rough. The equipment is relatively inexpensive.
- Gasoline or electric powered saws mounted on a stand. These saws are generally set up to be run wet but can be run with a dry diamond blade. Very accurate cuts can be made but in most cases the pavers must be marked, brought to the saw, cut, then returned to the edge and installed. The process is labor intensive. Gasoline powered saws may be mounted on a coxet to facilitate the process.
- Walk behind diamond saw. Powered in most cases by a gasoline engine, the units roll on wheels while cutting. They are usually set up to run wet but can use a dry diamond blade. The advantage is that the pavers may be cut in place. The quality of cut is excellent but the saws are awkward to maneuver.
- Gasoline powered cut-off or quick saws. These hand held saws are similar to chain saws with the diamond saw blade replacing the chain. While some cut-off saws can be run wet, most are used with dry blades. These units provide good output and, in the hands of an experienced operator, excellent quality of cut. Cut-off saws have become the most used equipment for cutting pavers.

Tips

Diamond saw blades come in wet or dry versions. Dry blades may be run wet but wet blades should never be run dry. Use of water with either type blade extends blade life.

Care must be taken to make sure that the slurry (mixture of water and cutting dust) from wet saws or dust from dry saws is washed off installed pavers immediately before it dries. Surrounding structures, vegetation and automobiles should be protected from the dust. Cut-off saws with dust collection capability have recently become available. Check with your Authorized Belgard Dealer for the proper cutting equipment.

Cuffing Procedure

Mark lines to be cut with lumber pencil or crayon, chalk, welders soapstone or water-base liquid marker. Do not use a marker which will not eventually come off. It is best to use a color which is easily visible against the color of the paver. Curved lines may be marked by using a garden hose as a guide.

The pavement will perform best if the size of cut units left in the pavement is as large as possible. Thin pieces tend to break or displace with time and use. In most cases, the pattern may be adjusted at or near the edge to allow for larger cut pieces. A border or header course of whole pavers between the field pavers and the edge restraint tends to keep the cut field pavers in place better than the edge restraint alone. The border pavers also add a neat finished appearance to the pavement.

Cut and place all edger pieces before compacting the pavers and applying joint sand.

Summary:

- Use proper hand, eye, ear and respiratory protection equipment.
- Mark lines to be cut.
- Maximize size of cut pieces to remain in pavement.
- Make clean neat cuts.
- Make all cuts before compacting pavement.
- Clean all cut residue from pavement immediately.
- Use paver border or header course as often as possible

PAVEMENT COMPACTION AND JOINT SANDING

Compaction of the ICP evens the tops of the pavers and begins the process of vertical interlock by forcing some of the bedding into the joints from the bottom.

On small jobs, compaction should take place after all pavers, including cut edges, are in place. On jobs lasting more than one day, all pavers placed should be compacted and the joints filled at the end of the workday. Do not compact or fill joints within 3 ft. of any unrestrained or incomplete edge. Do not spread joint sand before initial compaction of pavement.

Using a gasoline powered vibratory plate compactor with a minimum compaction force of 5000 ft. lbs. for 3-1/8 in. pavers, follow this procedure:

Compacting Procedure

- Start on one edge of the pavement and compact the perimeter.
- Compact in overlapping rows on the rest of pavement.
- Compact the pavement again but in the opposite direction. All pavers will need to be exposed to at least two passes of the compactor.
- Do not compact within 3 ft. of an unrestrained edge or the pavers will creep out.
- The operator looks for broken pavers just behind the plate compactor and marks them while compacting. The broken pavers are removed with a paver extractor and replaced with whole units.

JOINT SANDING

After compaction of pavement and replacement and recompaction of replacement pavers, spread the joint sand. Refer to Section 2, Joint Sand for recommended sands. Dry sand works best, so if the sand is damp, allow it to dry. Sweep the dry sand into the joints. If necessary, dry bagged sand conforming to ASTM C144 may be used (see Appendix A). Do not use mason sand, play sand or sandbox sand. After the initial sweeping, the filling of the joints can be expedited by alternating sweeping and passes of the vibratory plate compactor. Continue until all joints are filled. It is a good idea to reinspect a job two to three weeks after completion at which time it may be necessary to re-sweep sand into the joints.

Figure 3 Right

Compaction sequence working from the perimeter to the center of the pavement. All pavers should have two passes of the plate vibrator over them prior to filling the joints. After the joints are filled with sand, follow the same compaction sequence from the perimeter to the center.

Appendix A). Do not use mason sand, play sand or sandbox sand. After the initial sweeping, the filling of the joints can be expedited by alternating sweeping and passes of the vibratory plate compactor. Continue until all joints are filled. It is a good idea to reinspect a job two to three weeks after completion at which time it may be necessary to re-sweep sand into the joints.

Summary:

- Compact pavement after pavers are installed and before joint sand is spread.
- Replace broken pavers while compacting and before applying joint sand.
- Spread and dry joint sand.
- Sweep joint sand into joints and fill by alternating sweeping and vibrating.
- Check job in 2-3 weeks and re-sand if necessary.
- Sweep off excess sand. On some commercial jobs, excess sand may be left on the pavement to help ensure joints are filled.

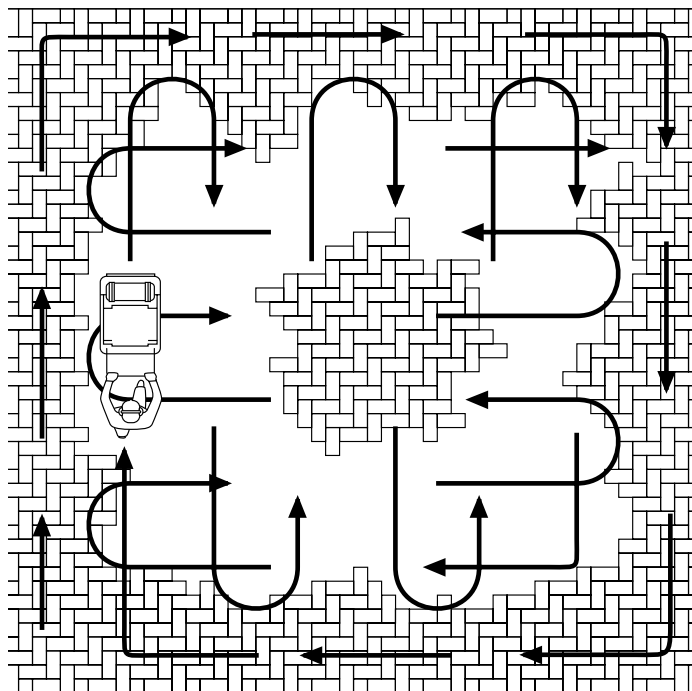

COMPLETION OF PROJECT

When the installation has been completed, clean up the site. Some pavers of each shape and color used may be left with owner for possible future replacement. Store these pavers neatly where the owner directs. Walk the job with the owner and address any problems immediately. Review maintenance procedures with the owner and leave information regarding care and maintenance with him/her.

ESTIMATING MATERIALS

EXCAVATION

Calculate the area to be excavated. Remember to include the 12 in. outside the area to be paved. If an electronic digitizer is not available, break the area down into geometric shapes (squares, rectangles, triangles or circles), calculate the area of each, then add all together to arrive at total area in square feet.

Calculate volume of soil to be excavated by multiplying the total area in square feet by the depth to be excavated in feet. This will give the total cubic feet of soil to be excavated. In most residential projects, the depth to be excavated is uniform or easily averaged over the area to be paved. If the pavement is to be cut into a hill slope or will be built partially over an area to be filled, be sure to consider these conditions in your estimate. In the first case, more material will need to be excavated and disposed of. Some or all of that material may possibly be used as fill.

When soil is excavated it expands in volume. This expansion is called "swell" and ranges from 30 percent for clay to 15 percent for sand with "average" soil expanding about 25 percent. If the average soil expands 25 percent then the volume after excavation, or loose volume, is 125 percent greater than the volume of the soil in place. Thus, if the calculated in place volume of the soil to be excavated is 100 cubic yards, the volume to be hauled is approximately 125 cu. yds. (100×1.25).

Since the volume of soil increases when excavated, the weight per unit of volume must decrease.

The average soil weighs approximately 3250 lbs. (1.625 tons) per cubic yard in place and approximately 2600 lbs. (1.3 tons) per cu. yds. after excavation. Thus, the 125 cu. yds. to be hauled in the last example would weigh 162.5 tons (125×1.3).

Knowing the volume and weight of soil to be excavated, hauled and disposed of is absolutely necessary to accurately estimate time and cost. More detailed information is contained in Appendix A-Materials.

BASE

Calculate the base material by multiplying the area excavated in square feet by the design depth of the base in feet after compaction. Divide the result by 27 to obtain the cubic yards of base material needed in the compacted state.

Since the base material will usually be purchased by the ton, the volume needed after compaction must be converted from cubic yards to tons. This conversion can be made accurately if the bulk density of the base material is known. If the bulk density is not known, multiply the calculated volume needed by 1.6 to get tons needed.

EDGE RESTRAINT

The lineal feet of edge restraint required is simply the total feet of pavement edge which must be restrained by the specified edge restraint system. In many cases, both straight and curved restraints must be installed. Total quantities of each should be estimated.

If the edge restraint to be used requires stakes or spikes, this quantity must also be estimated. Space stakes or spikes as recommended by the manufacturer of the edge restraint system used. This information may be obtained from your Authorized Belgard Dealer.

BEDDING SAND

The quantity of bedding sand will vary with the thickness of the loose screeded sand bed, 1 in. to 1-½ in., and with the moisture content of the sand being delivered. A good rule of thumb, however, is to order 1/2 ton of ASTM C33, washed concrete sand for every 100 sq. ft. of installed pavement. This should suffice for both the bedding and joint filling.

PAVERS

In simple straightforward projects requiring no cutting loss, the quantity of pavers to be ordered is equal to the area of the pavement, plus a 2 percent cull factor rounded up to the next highest package unit. In some cases it may be possible to order pavers in straps or section quantities while in others it may be necessary to order full cubes.

An additional quantity must be added for portions of pavers lost on edges which must be cut. A good rule of thumb is to add 30 sq. ft. of pavers for each 100 linear ft. of cut edge.

Edge pavers must be calculated separately for each paver shape. This information is available in the Product Guide available from your Authorized Belgard Dealer. Remember, edge pavers are only available for a limited number of paver shapes and may only be used on straight edges parallel to the laying pattern.

Border pavers, such as a header course, must be calculated based on the paver shape being used and the border pattern to be installed. In the common soldier course border using a 4 in. x 8 in. rectangular paver, 3 pavers are needed per 1 ft. of border or 0.67 sq. ft. of 4 in. x 8 in. pavers. The ordered quantity would be 0.67 x the lineal feet of border plus 2 percent rounded up to the next package unit.

If bands are to be inset into the paver field, it is usually best to lay the entire field then saw cut and remove field pavers to install the band pavers. In this case, do not deduct the quantity of band pavers from the gross field pavers required.

JOINT SAND

If the same sand used to fill the joints is used for the sand setting bed, the quantity will be included in the bedding sand estimate.

In non-vehicular residential projects, such as patios, dry bagged sand may be used. Use an all purpose or construction sand. Do not use play sand or sandbox sand. All purpose sand is generally packaged in 60 lb. bags. Use the table below to estimate quantity needed:

	<u>Lbs./100 sq. ft.</u>
6 cm. (2 ¾ in.) pavers w/ ⅛ in. joint	200 lbs.
8 cm. (3 ⅛ in.) pavers w/ ⅛ in. joint	265 lbs.
6 cm. (2 ¾ in.) pavers w/ rounded corners	300 lbs.
8 cm. (3 ⅛ in.) pavers w/ rounded corners	400 lbs.

JOINT SAND

If the sand used for the sand setting bed is not used for filling the joints, the sand used should meet the gradation requirements of ASTM C144.

ASTM C144 - Gradation of Joint Sand

Sieve Size	Percent Passing
No. 4	100
No. 8	95-100
No. 16	70-100
No. 30	40-75
No. 50	20-40
No. 100	10-25
No. 200	0-10

NOTE:

- Do not use sandbox or play sand.
- Do not use stone dust.
- Do not use Mason sand.

EDGE RESTRAINTS

Restraints hold the pavers tightly together, enabling consistent interlock of the units across the entire pavement. They prevent pavers from spreading due to horizontal forces from tires and minor settlement. Edge restraints are designed to remain stationary while receiving occasional impacts from tires.

When a compacted aggregate base supports the paver and bedding sand, the base should extend beyond the restraint. The rule of thumb is that the base should extend beyond the restraint the same dimension as the thickness of the base material. For example, if the base is 6 in. thick, then it should extend at least 6 in. beyond the outside edge of the restraints. This contributes stability to the restraint and pavement edge especially in soils subject to heaving. Soil backfill is never a suitable edge restraint and should never be installed on top of the bedding sand.

If there is a possibility of sand loss from beneath the pavers, or between the joints of the edge restraint, Geotextile (filter cloth) is recommended to prevent its migration. A 12 in. (0.3m.) wide strip can be applied along the base and turned up along the sides of the restraints. Filter cloth generally is not required across the entire surface of the base, nor should it be placed on top of the bedding sand.

There are two general types of edge restraints. Those made elsewhere and installed at the site include precast concrete, plastic, cut stone, aluminum, steel and timber. Restraints formed on-site are made of poured-in-place concrete.

Full depth precast concrete or cut stone edging generally extends the depth of the base material. They can be compacted soil (not subject to heaving), compacted aggregate or concrete backfill. The preferred method of installation with vehicular pavements is for the curb to rest on the compacted aggregate road base.

Partial depth precast concrete edge restraints may be used for residential and light duty commercial applications. These precast units are anchored on a compacted aggregate base with steel spikes. The spikes are typically 3/8 in. diameter. Depending on the design, the top on the concrete edge can be hidden or exposed.

Aluminum and steel edging should be selected to provide a smooth vertical surface against the pavers. L-shaped edging provides additional stability. Stakes fastened to the edging should be below the pavers or on the outside of the restraints. Steel should be painted or galvanized so that rust does not stain the pavers. Spikes to secure steel and aluminum edging should extend well into the base course. Consult manufacturer's literature for recommended spacing of the spikes. Aluminum and steel edgings are manufactured in different thickness. The thickest edging is recommended when pavers are subjected to vehicular traffic.

Timber should only be used to restrain residential patios and walks. It should be treated to resist insects and rot. A nominal 6 in. x 6 in. minimum dimension will restrain the bedding sand and 2 3/8 in. thick pavers. Smaller dimensioned lumber will likely warp. Stakes should be placed on the outside of the lumber, or below the pavers if placed on the inside. The stakes should extend into the base.

Plastic edging installs quickly and will not rust or rot. Plastic edging should be specifically designed for use with pavers. It can be used with light duty residential, commercial or on some heavy duty, industrial applications, depending on the design. It should be firmly anchored into the compacted aggregate base course with steel spikes. Consult the manufacturer's literature for the recommended spacing of the spikes. Edging for planting beds and lower gardens is not an acceptable restraint for interlocking concrete pavements.

Elevations should be set accurately for restraints that rest on the base. For example, 2 3/8 in. thick pavers with 1 1/4 in. of bedding sand would have a base elevation set 3 in. below that of the finish elevation of the pavers. This allows 1/4 in. settlement from compaction and 1/8 in. for minor settling over time.

Restraints formed on-site, poured-in-place concrete curbs, or combination curb and gutters required by municipalities make suitable restraints for pavers. Exposed concrete edges should have a 1/8 in. radius edge to reduce the likelihood of chipping. As with precast, the side of the curbs should extend well below the sand bedding course.

Troweled concrete from a bag mix, or batched on-site, can be applied without forms against edge pavers and on the compacted base. If the top of the concrete edge is recessed and slopes away from the pavers, grass can grow next to them. The depth below the surface of the pavers must be sufficient to prevent the concrete from becoming a heat sink that dries the grass and topsoil. This edge restraint is suitable for pavers subjected to pedestrian traffic and for residential driveways. Troweled edges should be at least 6 in. wide. Steel reinforcing such as DuraWall should be placed in the concrete to increase service life.

Troweled concrete curbs are not recommended in freezing climates as they may crack and be an on-going maintenance problem. The second letter describes a secondary soil type, the gradation or the ability of the soil to retain water. Gradation (variation in particle sizes)

W = well-graded (high variation - good for pavements)

P = poorly graded (low variation - not good for pavements)

Liquid Limit Symbols (Liquid limit is the ability of the soil to hold water)

H = high (can hold water, does not drain well - not good for pavements)

L = low (does not hold water, drains well - good for pavements)

BASE MATERIAL

The specification for aggregate base materials for use under flexible asphalt pavement are suitable for use as base material under ICP. If no municipal, county or state specifications are available, use material meeting the specifications of ASTM D 2940 as shown below.

Sieve Size	Percent Passing
2 in	100
1-1/2 in	95-100
3/4 in	70-89
3/8 in	50-70
No. 4	35-55
No. 30	12-55
No. 200	0-8

The material meeting this specification is suitable for bases more than 4 in. thick. For bases less than 4 in. thick, the material should have 100 percent passing the 1-1/2 in. sieve and 95-100 percent passing the 3/4 in. sieve. In either case, the material passing the No. 200 sieve must not be greater than 10 percent.

SAND SETTING BED

The setting bed materials must be a coarse, sharp, washed sand. It may be a processed natural sand or a man made sand. It must meet the gradation specifications of ASTM C33. The most common term for the proper sand is "Washed Concrete Sand".

ASTM C33 - Gradation to Bedding Sand.

NOTE:

1. Do not use stone dust or unwashed screenings.
2. Do not use mason or bank sand.

THE 14 USCS SOIL GROUPS AND THEIR RESPECTIVE SUITABILITY FOR USE AS A SUBGRADE FOR A PAVEMENT SYSTEM ARE:

SYMBOL	SOIL DESCRIPTION	SUBGRADE SUITABILITY			
		Poor	Med	Good	Excellent
GW	Well-graded gravels and gravel sand mixtures, little or no fines				X (1)
GP	Poorly graded gravels and gravel sand mixtures, little or no fines				X (1)
GM	Silty gravels, gravel-silt-clay mixtures				X (1)
GC	Clay gravels, gravel-sand-clay mixtures				X (1)
SW	Well-graded sand and gravelly sands, little or no fines				X (1)
SP	Poorly graded sands and gravelly sands, little or no fines			X (1)	
SM	Silty sands, sand-silt mixtures			X (1)	
SC	Clay sands, sand-silt mixtures			X (1)	
ML	Inorganic silts, very fine sands, rock flour, silty or clayish fine sands		X (2)		
CL	Inorganic clays of low to medium plasticity, gravelly clays, silty clays, lean clays		X (2)		
MH	Inorganic silts, micaceous or diatomaceous fine sands or silts, plastic silts	X (3)			
CH	Inorganic clays or high plasticity fat clays	X (3)			
OH	Organic clays of medium to high plasticity	X (3)			
Pt	Peat	X (3)			

(1) Use 6 in. compacted base in driveways.

(2) Use Geotextile between subgrade and base and thickness base to 8-in in driveways.

(3) Use Geotextile between subgrade and base and thickness base to 8-in in driveways and thicken driveway base to 10-in.

PLASTIC EDGE RESTRAINT

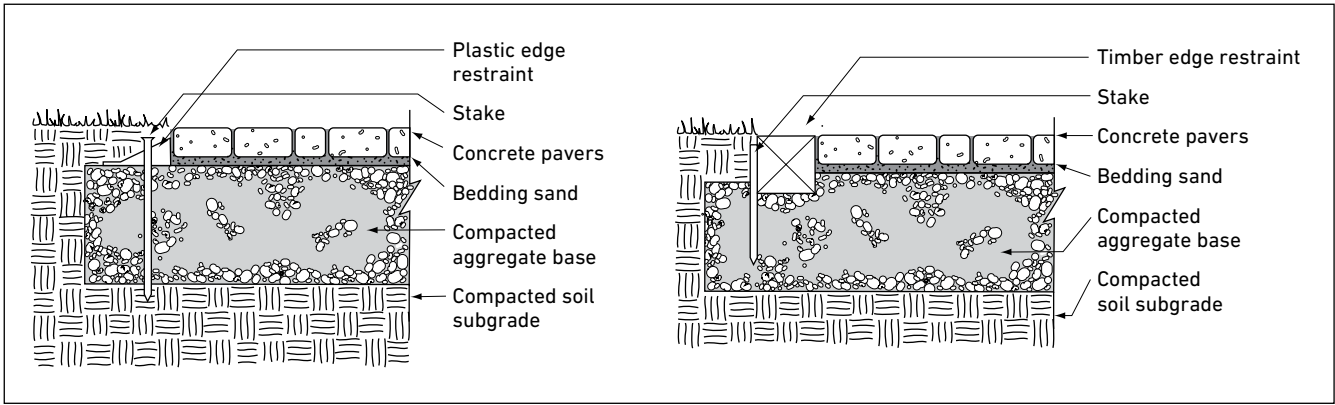

TIMBER EDGE RESTRAINT

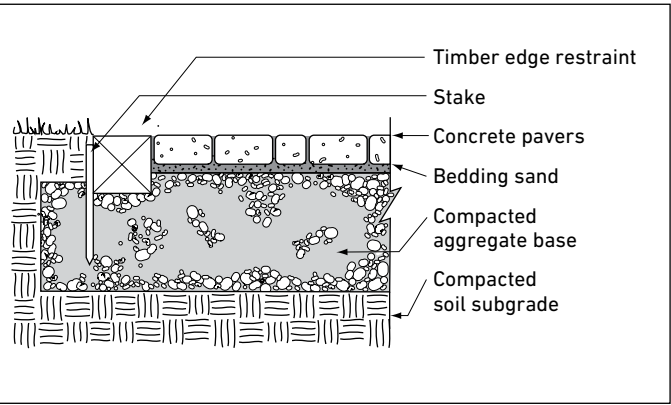

ALUMINUM AND STEEL EDGING

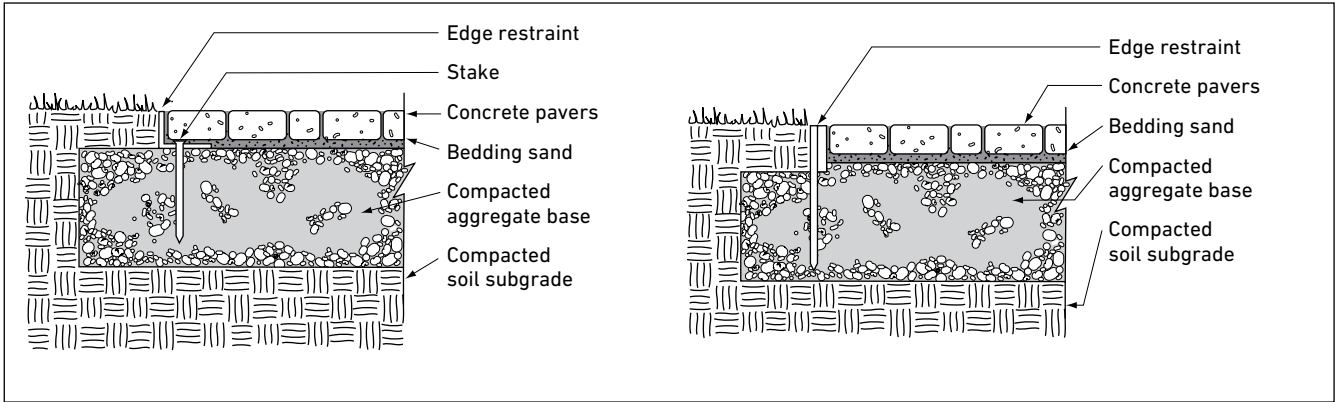

TROWELED CONCRETE AND "SUBMERGED CURB" EDGES

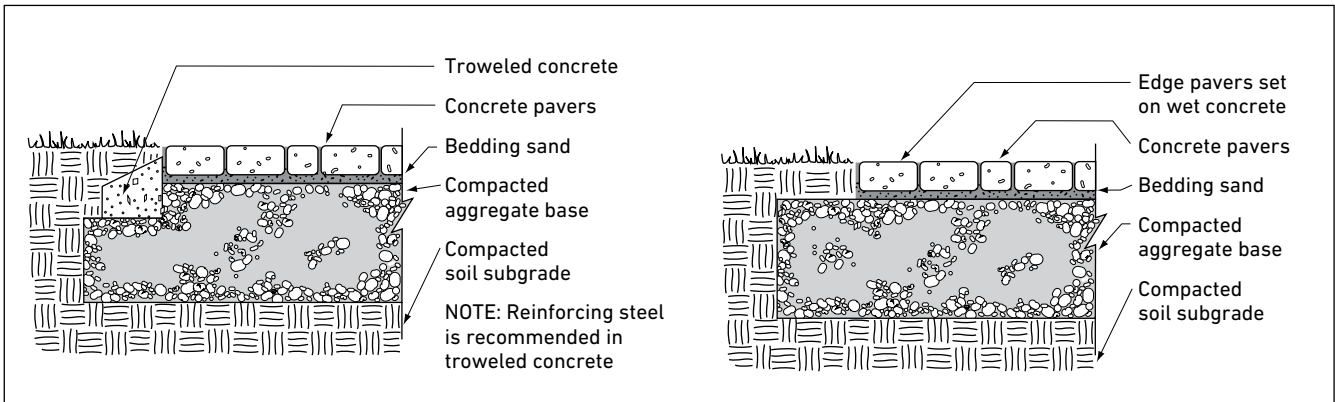

POURED-IN-PLACE CONCRETE CURBS

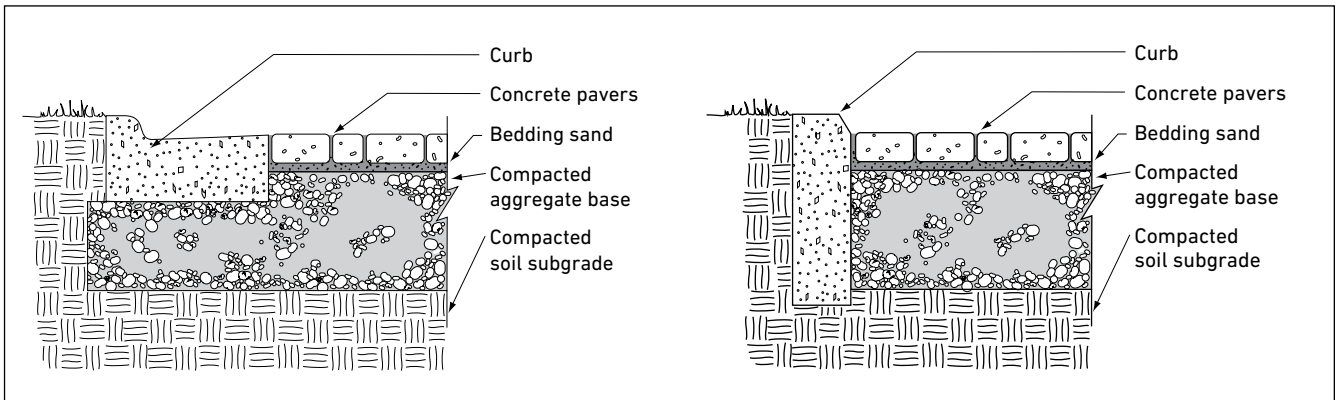

PARTIAL DEPTH PRECAST CONCRETE EDGE

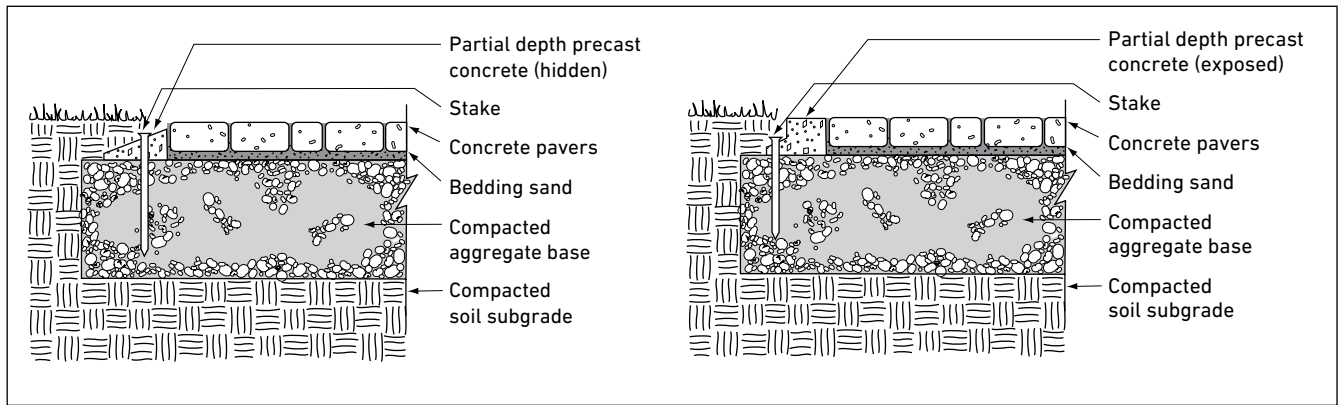

PRECAST CONCRETE/CUT STONE

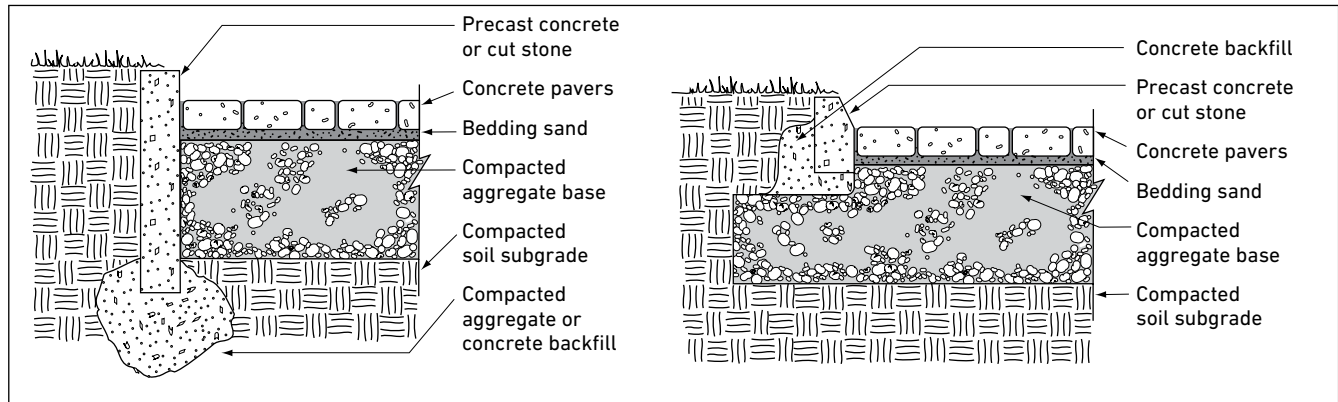

UTILITY MANHOLE

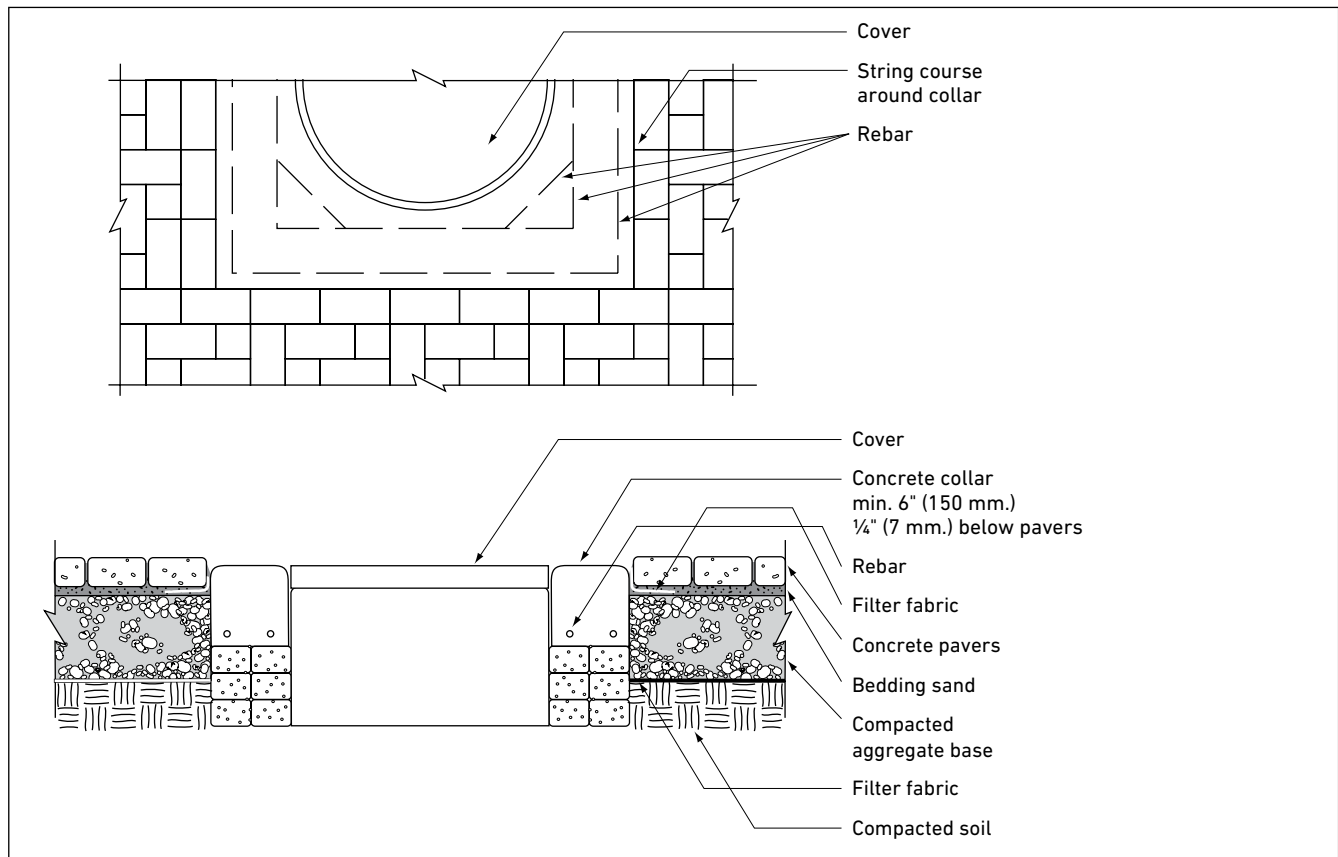

APPENDIX A

MATERIALS

GENERAL

Gradation of subgrade soil, base material and bedding and joint sands is an important property of these materials. The size and distribution of their particle sizes greatly influence their performance under interlocking concrete pavements and therefore the performance of the pavement. Gradation is determined by placing a known weight of dry material in the uppermost of a stack of sieves or screens. Each sieve going down the stack has smaller openings than the one above it with the bottom unit a pan to catch the finest particles. After the sieves are shaken for a specified amount of time, the material retained on each sieve is weighed and the percentage of material passing each sieve is calculated. There are standardized ASTM tests for determining the gradations of soils, base materials, bedding and joint sands.

SUBGRADE SOILS

Subgrade soils range in particle size from coarse grained sands to fine grained silts and the finest grained clays.

Most soils are a combination of the three particle size categories. In general, the soils containing a high percentage of clay particles are less suitable for good subgrade support of a pavement.

Of the several systems used to classify soils with respect to their ability to support a pavement system, the Unified Soil Classification System (USCS) used by the Army Corps of Engineers is probably the easiest to use. This system is also described as ASTM D 2487, Standard Classification

of Soils for engineering purposes. In this system, soils are separated into 15 groups which are each designated by a two letter code.

The first letter describes the predominate soil type:

G = gravels or gravelly soils

S = sand or sandy soils

M = silt - non-plastic (non putty-like when wet), or very slightly plastic, and having little or no strength when air dry

C = clay - plastic (putty-like when wet), and having considerable strength when wet.

Pt = peat - vegetation in various stages of decomposition usually black or dark brown in color

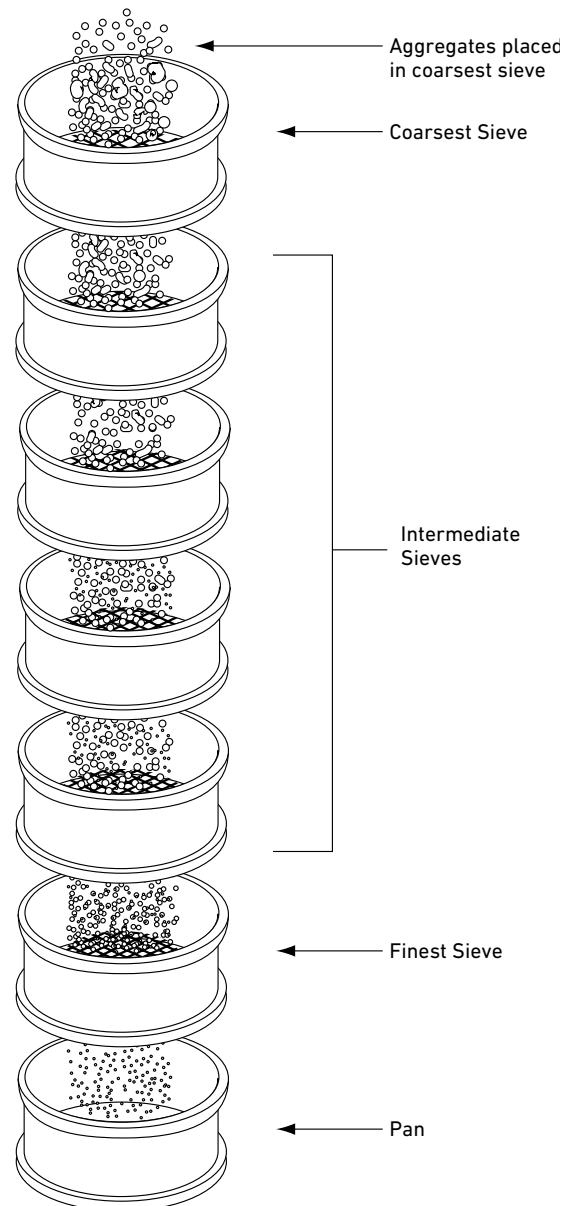



Scan for additional
product information

PEDESTRIAN	LIGHT/REGULAR TRAFFIC	HEAVY TRAFFIC	PERMEABLE	ADA	DURAFUSION PROCESS
✓				✓	✓

SHAPES & SIZES

12 x 24



12 x 24 x 2³/₈

UNIT	SQFT/ PALLET	SQFT/ LAYER	LAYER/ PALLET	UNITS/ PALLET	UNITS/ LAYER	UNITS/ SQFT	WEIGHT/ PALLET
60MM							
12 X 24 X 2 ³ / ₈	120	12	10	60	6	.5	3120

NOTES:

AutoCAD® hatch pattern files can be downloaded from belgard.com for use in architectural drawings

Some patterns may not necessarily reflect the percentages of stone sizes within a particular pallet. In some cases you may have extras in one or more of the sizes. This must be accounted for in your planning and design.

Percentages are based on area by paver.

3-PIECE PATTERN A

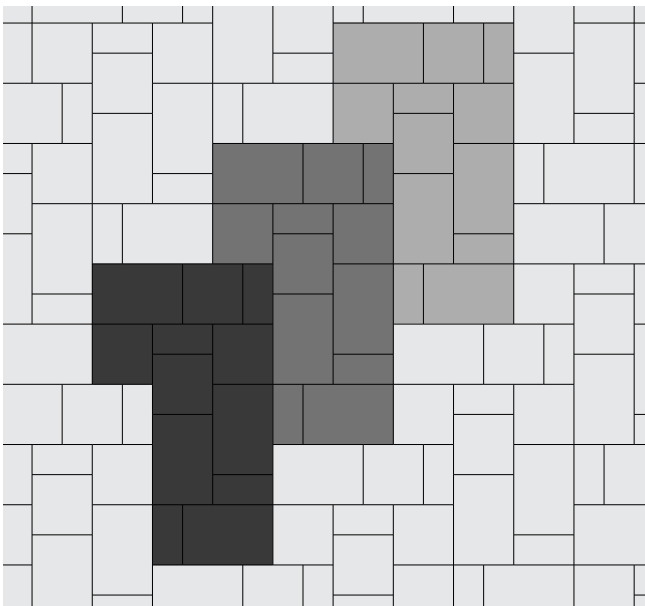

3-PIECE PATTERN B

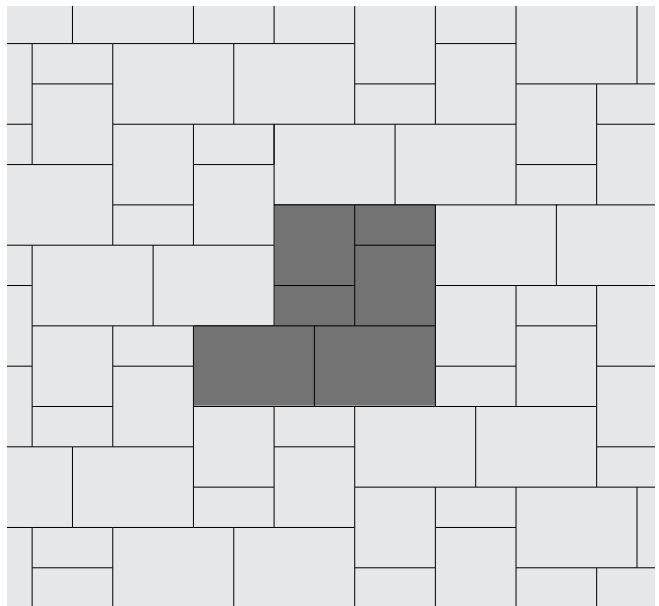

3-PIECE HERRINGBONE PATTERN

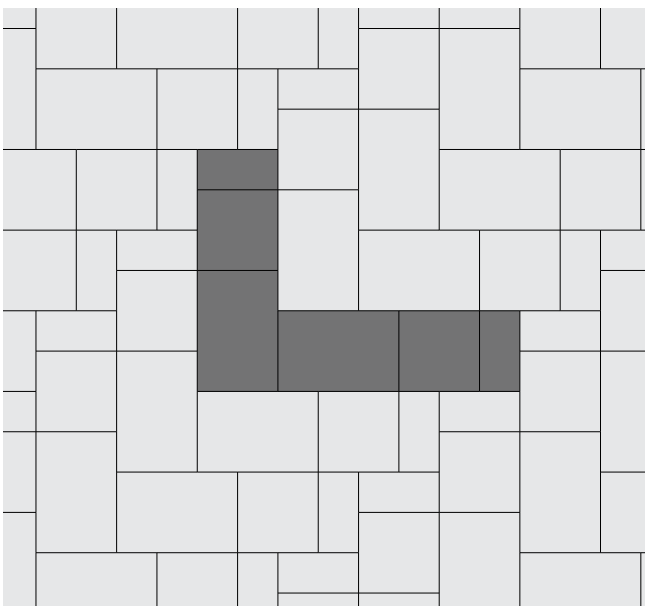



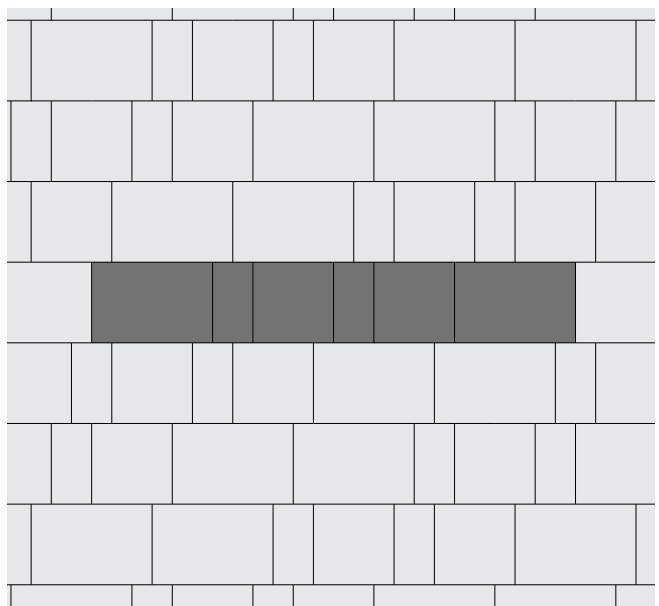

3-PIECE RUNNING BOND PATTERN





Scan for additional
product information

PEDESTRIAN	LIGHT/REGULAR TRAFFIC	HEAVY TRAFFIC	PERMEABLE	ADA
				
✓			✓	

SHAPES & SIZES

Multi-Piece



Variable x 2³/₈

UNIT	SQFT/ PALLET	SQFT/ LAYER	LAYER/ PALLET	UNITS/ PALLET	UNITS/ LAYER	UNITS/ SQFT	WEIGHT/ PALLET
MULTI-PIECE							
VARIABLE X 2³/₈	85	9	8	–	–	–	2040

NOTES:

AutoCAD® hatch pattern files can be downloaded from belgard.com for use in architectural drawings





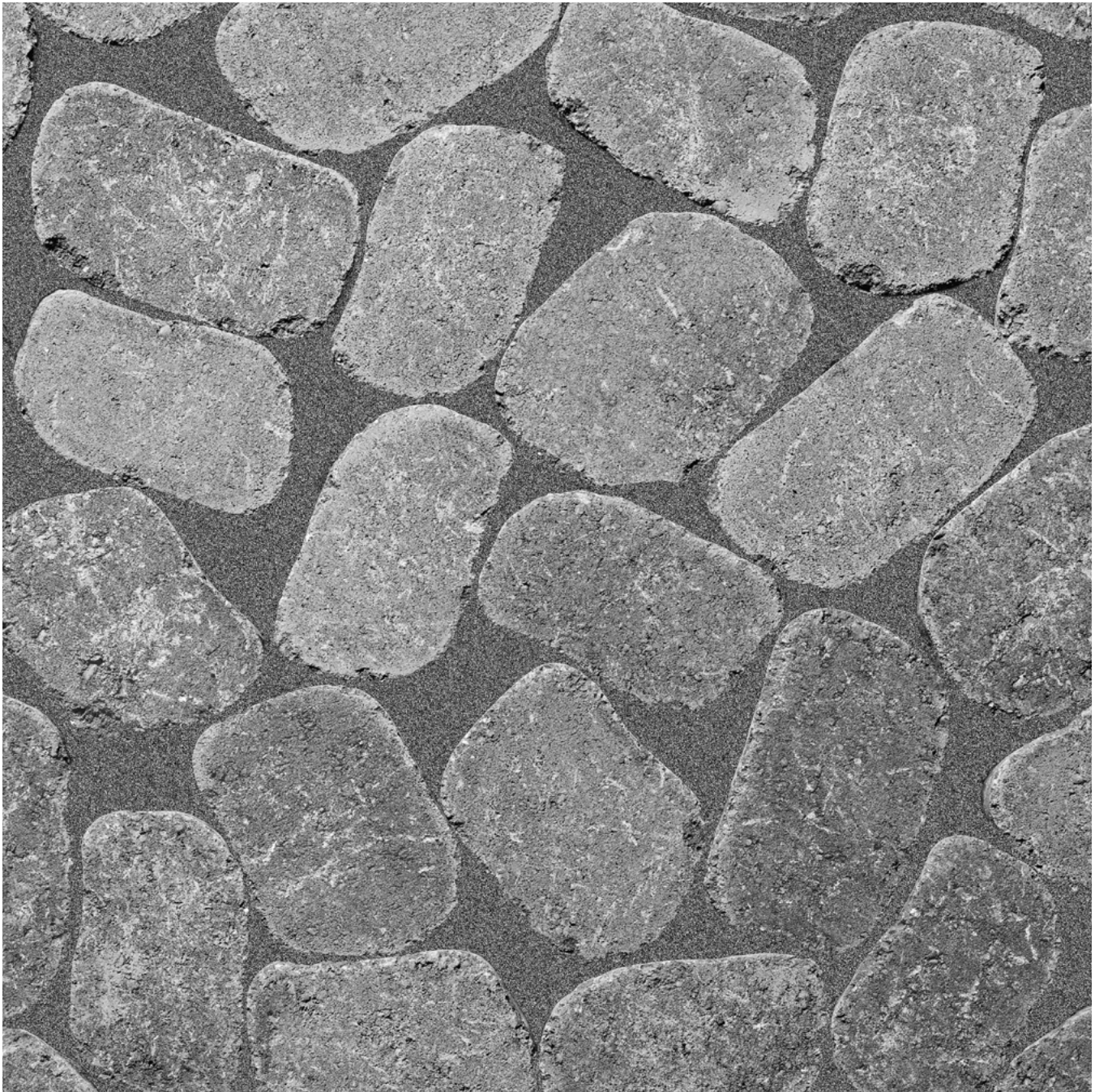

Some patterns may not necessarily reflect the percentages of stone sizes within a particular pallet. In some cases you may have extras in one or more of the sizes. This must be accounted for in your planning and design.

Percentages are based on area by paver.





Scan for additional
product information

PEDESTRIAN	LIGHT/REGULAR TRAFFIC	HEAVY TRAFFIC	PERMEABLE	ADA	DURAFUSION PROCESS
					
✓	✓				✓

SHAPES & SIZES

3 x 9



3 x 9 x 2³/₈

UNIT	SQFT/ PALLET	SQFT/ LAYER	LAYER/ PALLET	UNITS/ PALLET	UNITS/ LAYER	UNITS/ SQFT	WEIGHT/ PALLET
------	-----------------	----------------	------------------	------------------	-----------------	----------------	-------------------

MULTI-PIECE

3 X 9 X 2 ³ / ₈	99.5	9.95	10	550	55	5.33	2784
---------------------------------------	------	------	----	-----	----	------	------

NOTES:

AutoCAD® hatch pattern files can be downloaded from belgard.com for use in architectural drawings

Some patterns may not necessarily reflect the percentages of stone sizes within a particular pallet. In some cases you may have extras in one or more of the sizes. This must be accounted for in your planning and design.

Percentages are based on area by paver.

1-PIECE RUNNING BOND PATTERN

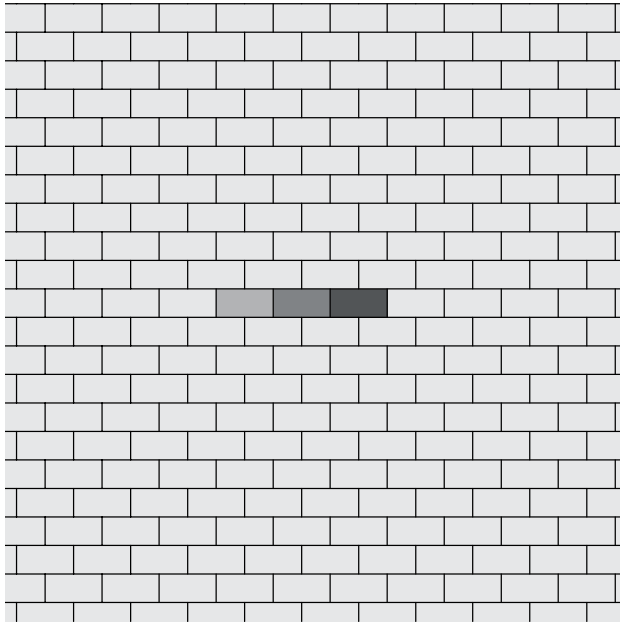

1-PIECE HERRINGBONE PATTERN

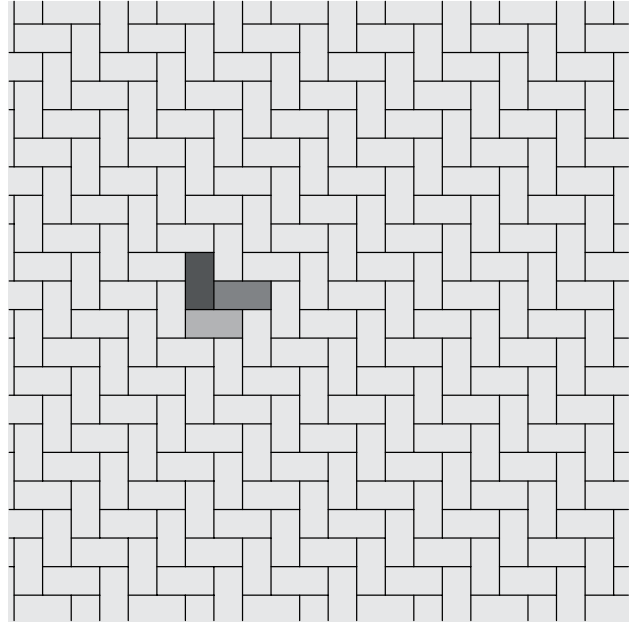



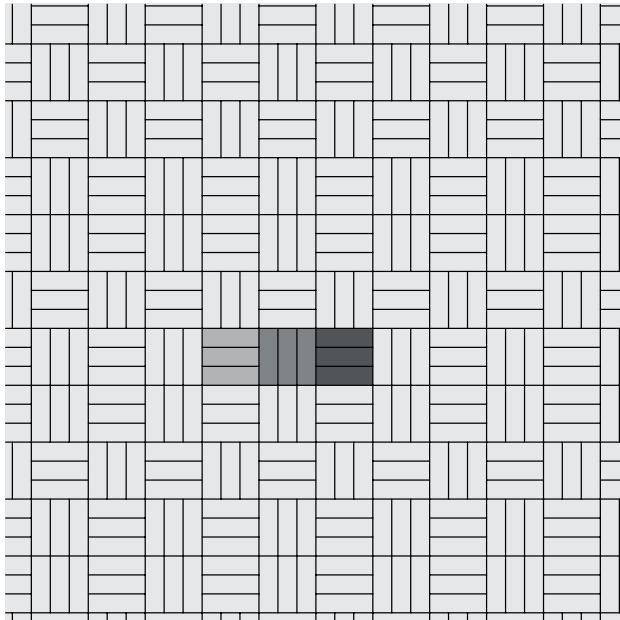

1-PIECE BASKET WEAVE PATTERN





Scan for additional product information

PEDESTRIAN	LIGHT/REGULAR TRAFFIC	HEAVY TRAFFIC	PERMEABLE	ADA
				
✓	✓			

SHAPES & SIZES

2-Piece

6 x 9

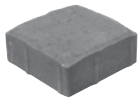

6 x 6 x 2³/₈

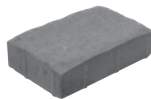

6 x 9 x 2³/₈



6 x 9 x 2³/₈

UNIT	SQFT/ PALLET	SQFT/ LAYER	LAYER/ PALLET	UNITS/ PALLET	UNITS/ LAYER	UNITS/ SQFT	WEIGHT/ PALLET
2-PIECE							
6 X 6 X 2 ³ / ₈	27	2.25	–	108	9	4	–
6 X 9 X 2 ³ / ₈	85.5	7.125	–	228	19	2.67	–
TOTAL	112.5	9.375	12	336	–	–	2868
6 X 9							
6 X 9 X 2 ³ / ₈	112.5	11.25	10	300	30	2.67	2970

Cambridge 2pc sourced from our Greensboro and Cowpens production facilities are 112.5 SqFt per pallet.
Cambridge 2pc sourced from our Holly Hill production facility is packaged 108 SqFt per pallet and 12 SqFt per layer.

NOTES:

AutoCAD® hatch pattern files can be downloaded from belgard.com for use in architectural drawings

Some patterns may not necessarily reflect the percentages of stone sizes within a particular pallet. In some cases you may have extras in one or more of the sizes. This must be accounted for in your planning and design.

Percentages are based on area by paver.

100% 6 x 9 Rectangles

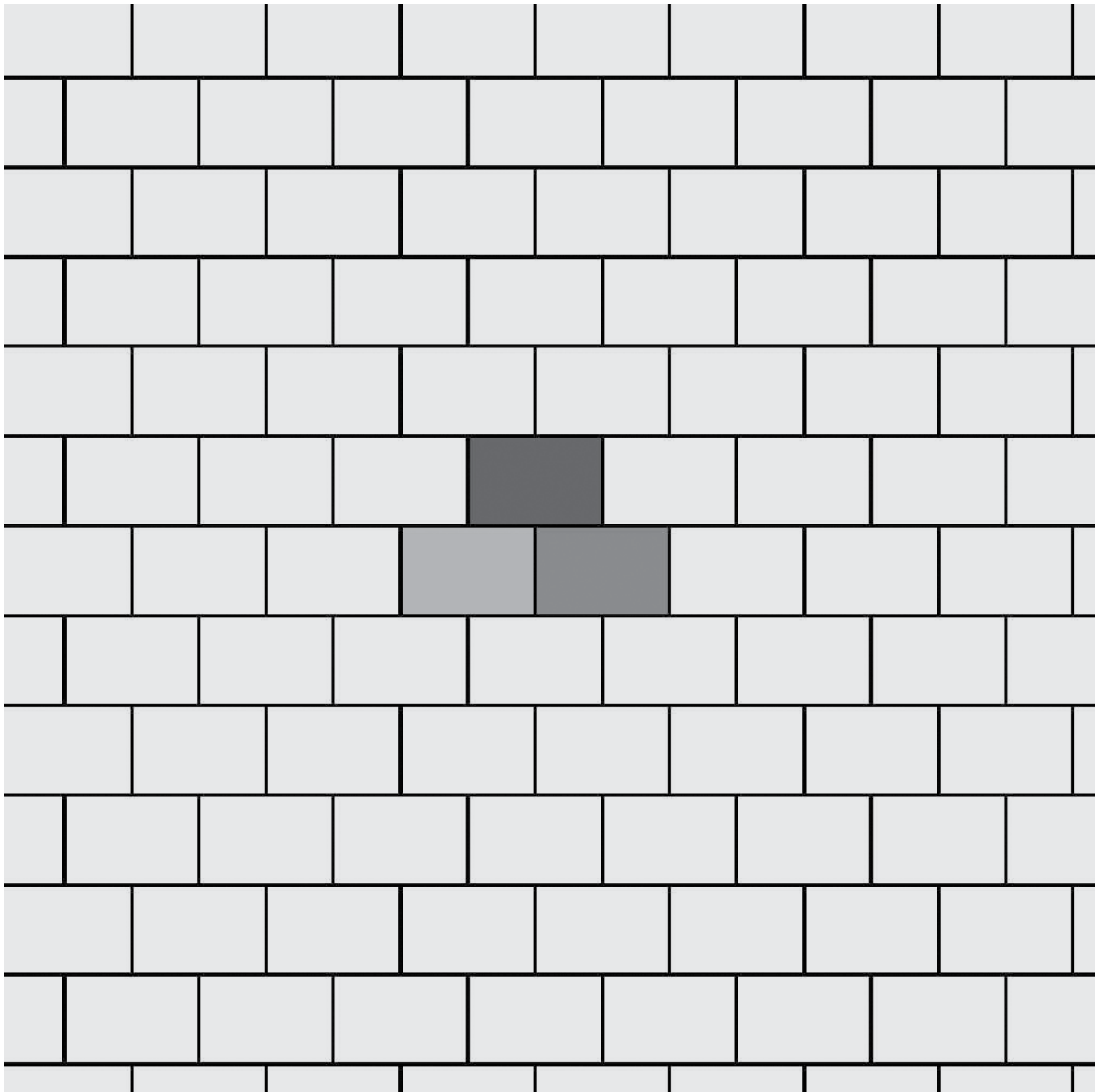

NOTES:

AutoCAD® hatch pattern files can be downloaded from belgard.com for use in architectural drawings

Some patterns may not necessarily reflect the percentages of stone sizes within a particular pallet. In some cases you may have extras in one or more of the sizes. This must be accounted for in your planning and design.

Percentages are based on area by paver.

100% 6 x 9 Rectangles

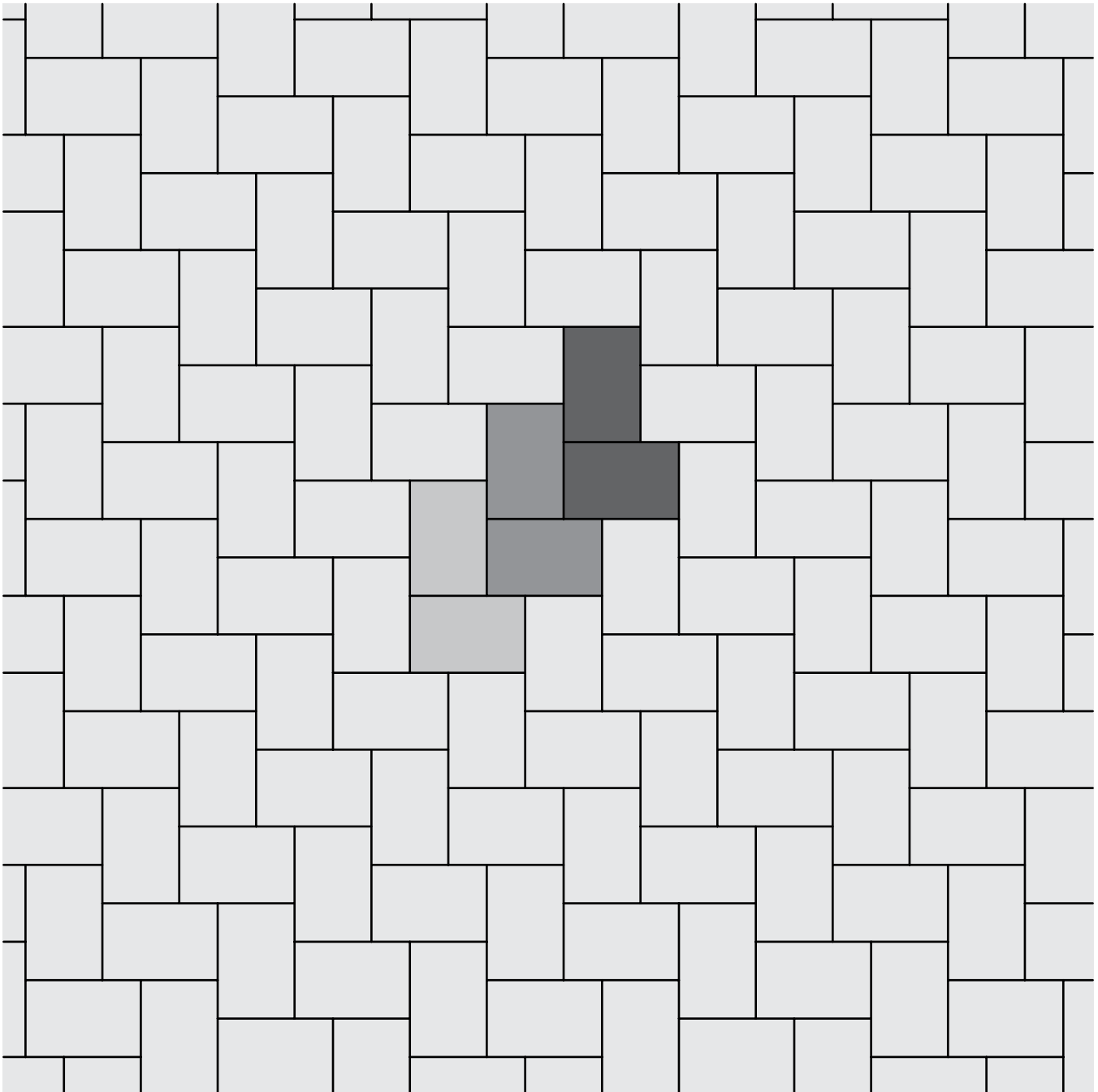

NOTES:

AutoCAD® hatch pattern files can be downloaded from belgard.com for use in architectural drawings

Some patterns may not necessarily reflect the percentages of stone sizes within a particular pallet. In some cases you may have extras in one or more of the sizes. This must be accounted for in your planning and design.

Percentages are based on area by paver.

25% 6 x 6 Squares



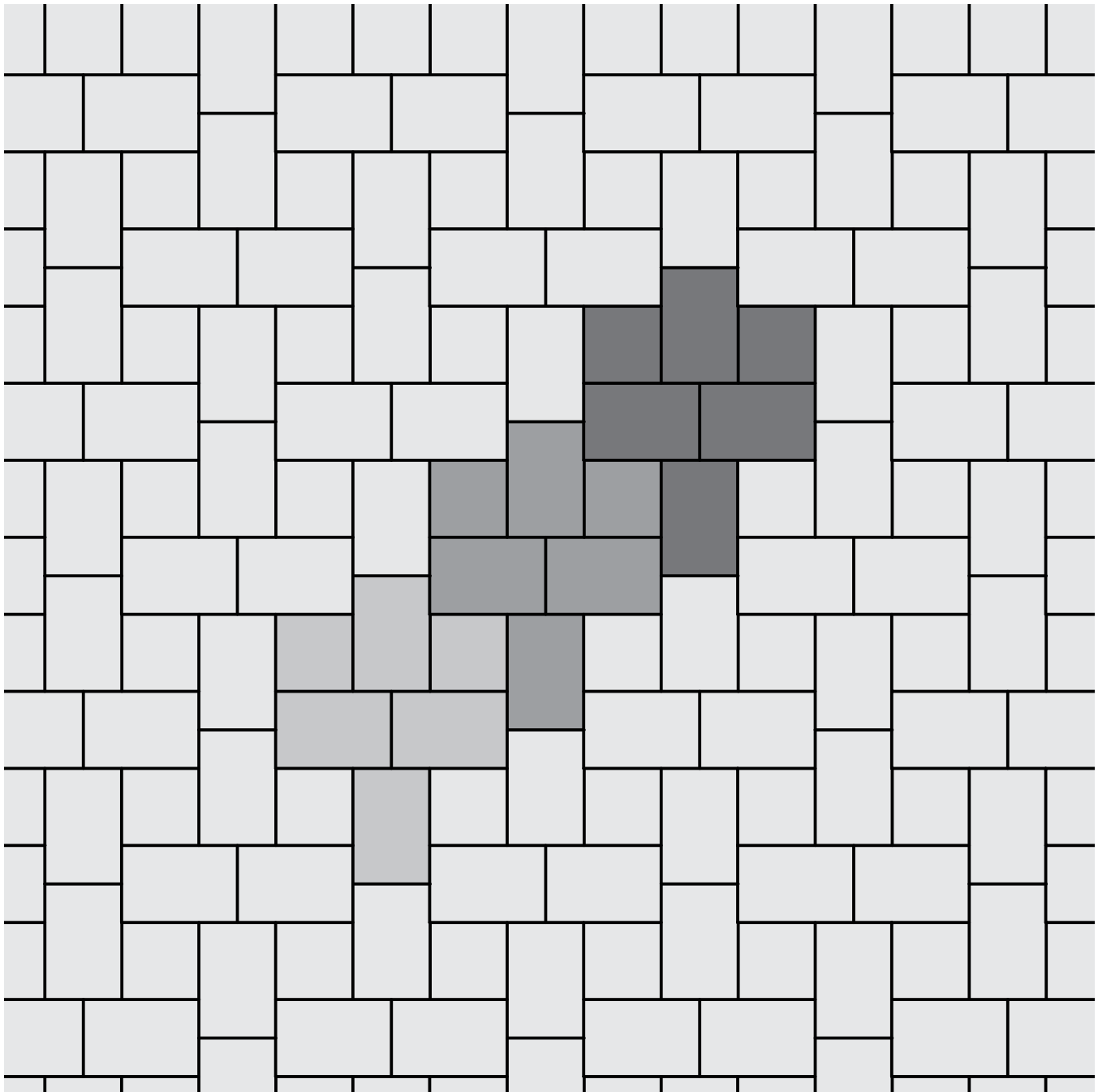

75% 6 x 9 Rectangles



DIMENSIONS™ 6



Scan for additional
product information

PEDESTRIAN	LIGHT/REGULAR TRAFFIC	HEAVY TRAFFIC	PERMEABLE	ADA
				
✓	✓			✓

SHAPES & SIZES

3-Piece



3 x 6 x 2³/₈



6 x 6 x 2³/₈



6 x 9 x 2³/₈

UNIT	SQFT/ PALLET	SQFT/ LAYER	LAYER/ PALLET	UNITS/ PALLET	UNITS/ LAYER	UNITS/ SQFT	WEIGHT/ PALLET
3-PIECE							
3 X 6 X 2³/₈	20	2	–	160	–	8	–
6 X 6 X 2³/₈	40	4	–	160	–	4	–
6 X 9 X 2³/₈	60	6	–	160	–	2.67	–
TOTAL	120	12	10	480	48	–	3180



NOTES:

AutoCAD® hatch pattern files can be downloaded from belgard.com for use in architectural drawings

Some patterns may not necessarily reflect the percentages of stone sizes within a particular pallet. In some cases you may have extras in one or more of the sizes. This must be accounted for in your planning and design.

Percentages are based on area by paver.

17% 3 x 6

33% 6 x 6

50% 6 x 9



Scan for additional laying pattern options



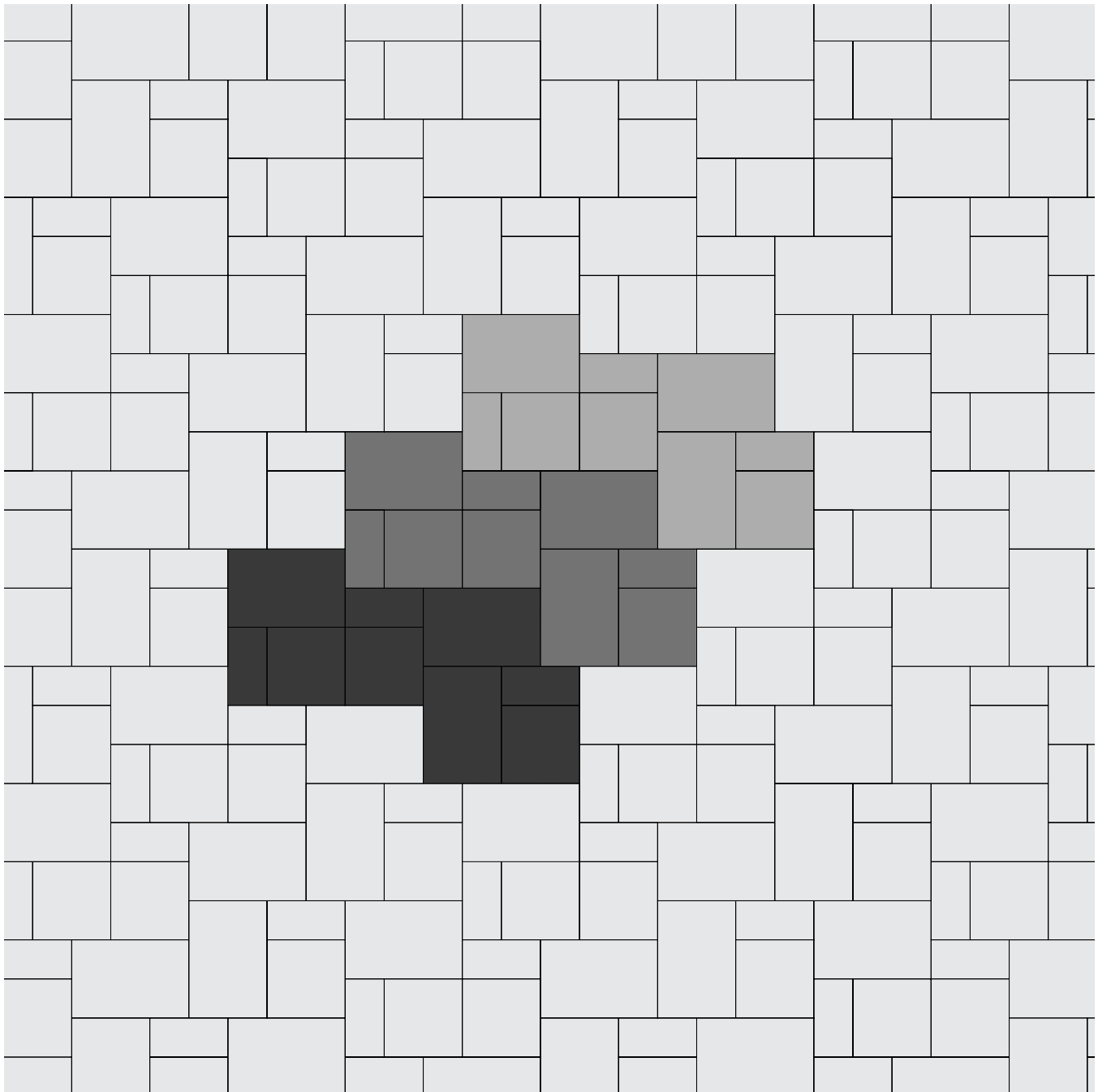



Pattern can also used for Origins™ 6 found on page 61.



DIMENSIONS™ 12



Scan for additional
product information

PEDESTRIAN	LIGHT/REGULAR TRAFFIC	HEAVY TRAFFIC	PERMEABLE	ADA	DURAFUSION PROCESS
					
✓				✓	✓*

SHAPES & SIZES

3-Piece



6 x 12 x 2³/₈

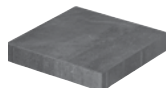

12 x 12 x 2³/₈



12 x 18 x 2³/₈

UNIT	SQFT/ PALLET	SQFT/ LAYER	LAYER/ PALLET	UNITS/ PALLET	UNITS/ LAYER	UNITS/ SQFT	WEIGHT/ PALLET
3-PIECE							
6 X 12 X 2³/₈	20	2	–	40	–	2	–
12 X 12 X 2³/₈	40	4	–	40	–	1	–
12 X 18 X 2³/₈	60	6	–	40	–	0.67	–
TOTAL	120	12	10	120	12	–	3180

*Dimensions 12 available in Durafusion.



NOTES:

AutoCAD® hatch pattern files can be downloaded from belgard.com for use in architectural drawings

Some patterns may not necessarily reflect the percentages of stone sizes within a particular pallet. In some cases you may have extras in one or more of the sizes. This must be accounted for in your planning and design.

Percentages are based on area by paver.

17% 6 x 12

33% 12 x 12

50% 12 x 18



Scan for additional laying pattern options

Pattern can also used for Origins™ 12 found on page 62.

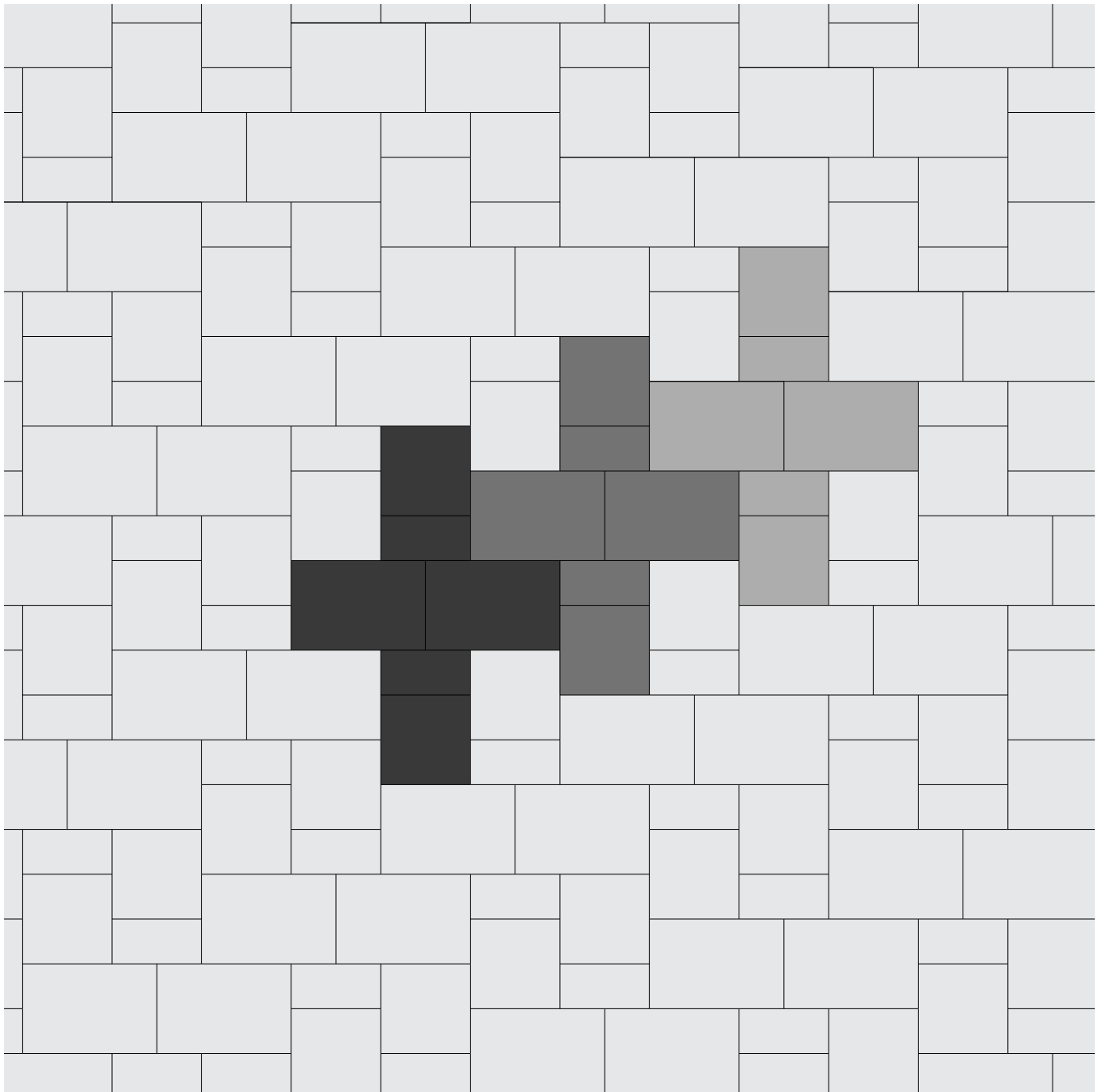



NOTES:

AutoCAD® hatch pattern files can be downloaded from belgard.com for use in architectural drawings

Some patterns may not necessarily reflect the percentages of stone sizes within a particular pallet. In some cases you may have extras in one or more of the sizes. This must be accounted for in your planning and design.

Percentages are based on area by paver.

17% 6 x 12

33% 12 x 12

50% 12 x 18



Scan for additional laying pattern options



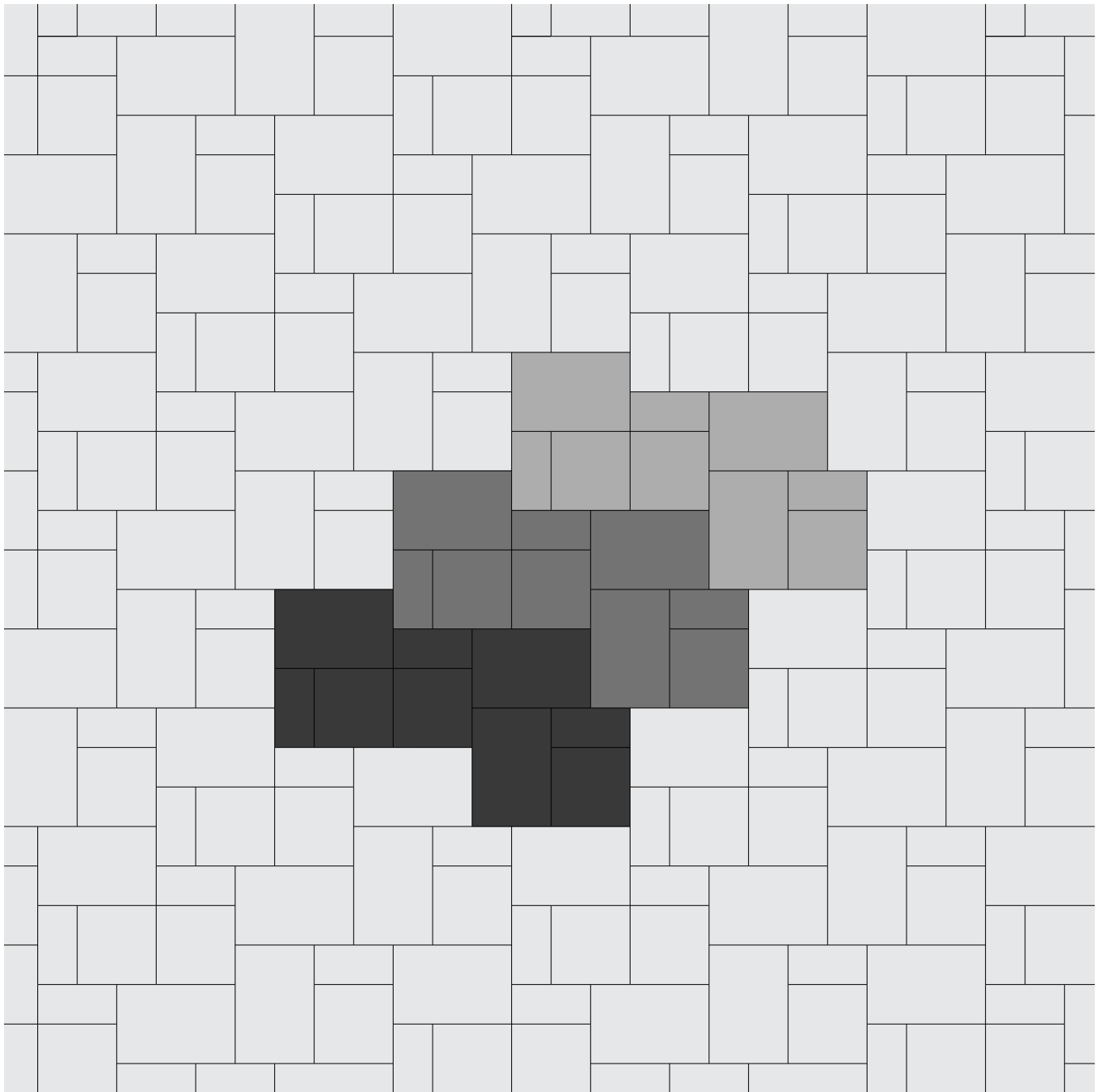



Pattern can also used for Origins™ 12 found on page 62.



DIMENSIONS™ 18



Scan for additional
product information

PEDESTRIAN	LIGHT/REGULAR TRAFFIC	HEAVY TRAFFIC	PERMEABLE	ADA	DURAFUSION PROCESS
					
✓				✓	✓*

SHAPES & SIZES

3-Piece

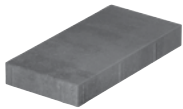

9 x 18 x 2³/₈

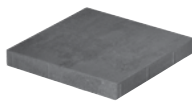

18 x 18 x 2³/₈

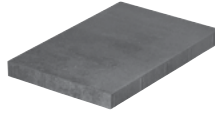

18 x 27 x 2³/₈

UNIT	SQFT/ PALLET	SQFT/ LAYER	LAYER/ PALLET	UNITS/ PALLET	UNITS/ LAYER	UNITS/ SQFT	WEIGHT/ PALLET
3-PIECE							
9 X 18 X 2³/₈	22.5	2.25	–	20	2	0.89	–
18 X 18 X 2³/₈	22.5	2.25	–	10	1	0.44	–
18 X 27 X 2³/₈	67.5	6.75	–	20	2	0.30	–
TOTAL	112.5	11.3	10	50	5	–	2981.3

*Dimensions 18 available in Durafusion.



NOTES:

AutoCAD® hatch pattern files can be downloaded from belgard.com for use in architectural drawings

Some patterns may not necessarily reflect the percentages of stone sizes within a particular pallet. In some cases you may have extras in one or more of the sizes. This must be accounted for in your planning and design.

Percentages are based on area by paver.

17% 9 x 18

33% 18 x 18

50% 18 x 27



Scan for additional laying pattern options

Pattern can also used for Origins™ 18 found on page 63.

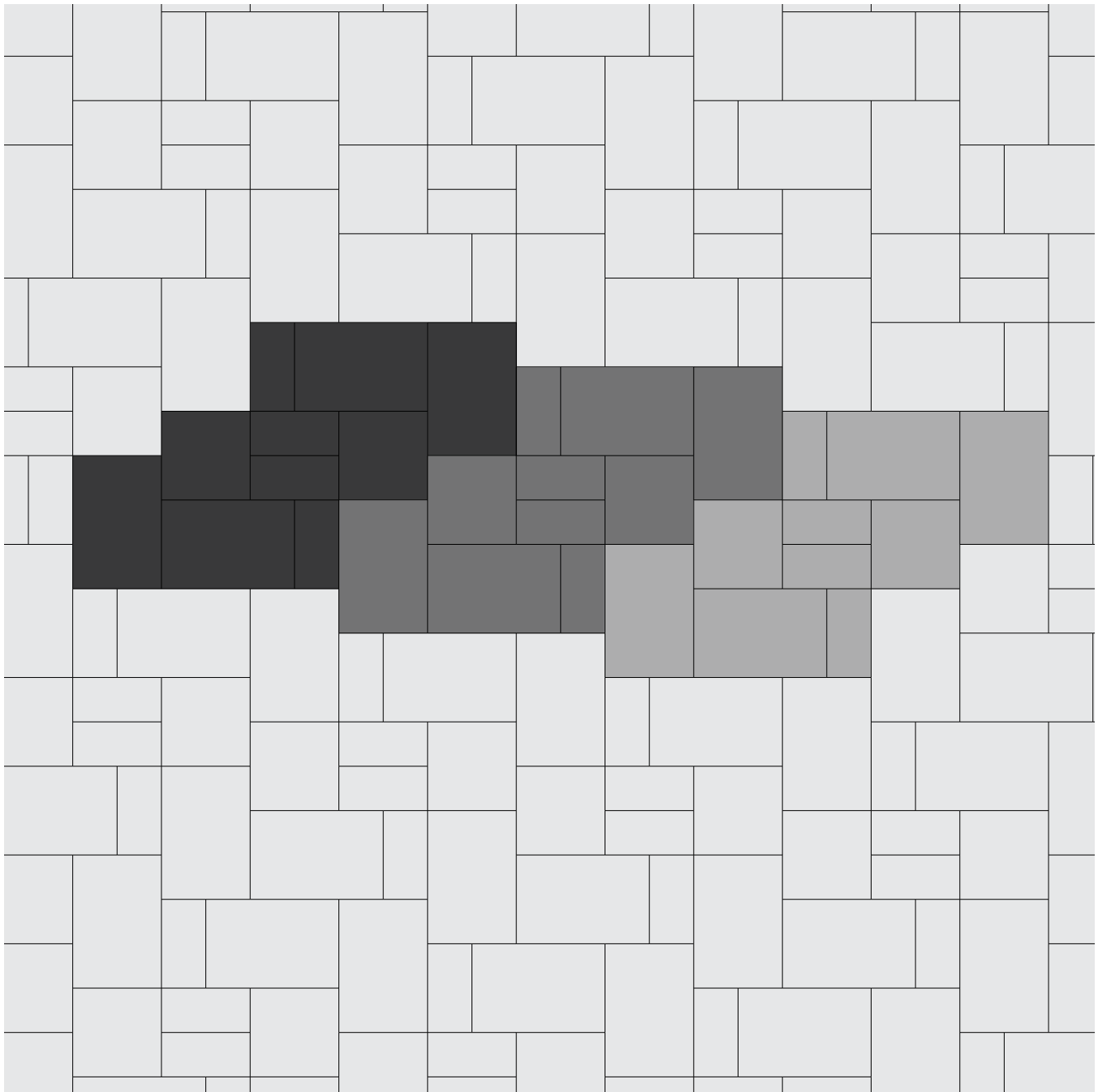



NOTES:

AutoCAD® hatch pattern files can be downloaded from belgard.com for use in architectural drawings

Some patterns may not necessarily reflect the percentages of stone sizes within a particular pallet. In some cases you may have extras in one or more of the sizes. This must be accounted for in your planning and design.

Percentages are based on area by paver.

30% Dimensions 6

15% Dimensions 12

55% Dimensions 18



Scan for additional laying pattern options



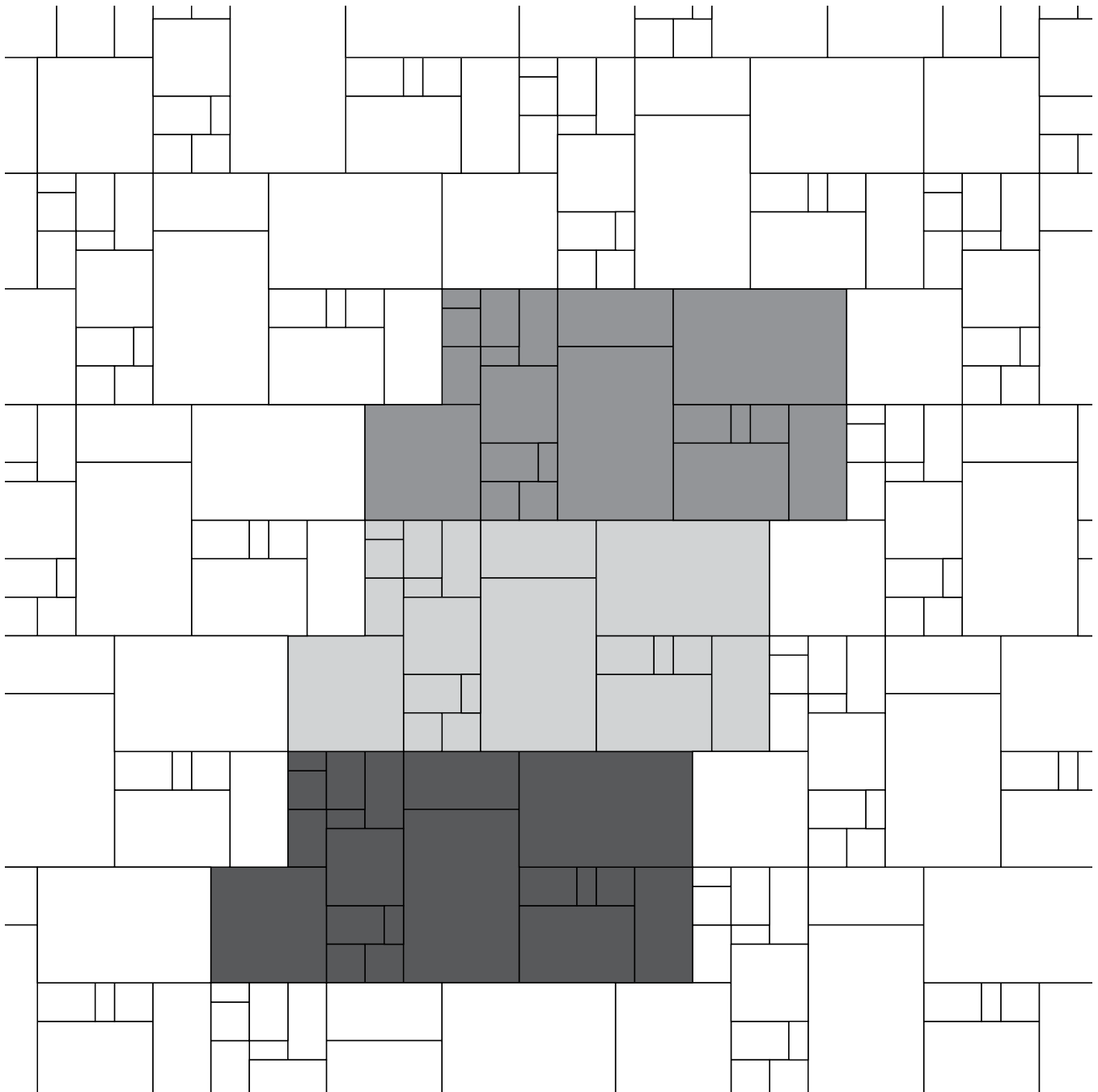

Pattern can also used for Origins™ found on pages 61-63.



DIMENSIONS™ ACCENT



Scan for additional
product information

PEDESTRIAN	LIGHT/REGULAR TRAFFIC	HEAVY TRAFFIC	PERMEABLE	ADA
				
✓				✓

*Durafusion Accent 6 x 9 only

SHAPES & SIZES

3 x 3



3 x 3 x 2³/₈

3 x 9



3 x 9 x 2³/₈

6 x 6



6 x 6 x 2³/₈

6 x 9*







6 x 9 x 2³/₈

UNIT	SQFT/ PALLET	SQFT/ LAYER	LAYER/ PALLET	UNITS/ PALLET	UNITS/ LAYER	UNITS/ SQFT	WEIGHT/ PALLET
3 X 3							
3 X 3 X 2³/₈	96.25	9.62	10	1540	–	16	2551
3 X 9							
3 X 9 X 2³/₈	103.1	10.3	10	550	–	5.33	2732.9
6 X 6							
6 X 6 X 2³/₈	120	12	10	480	–	4	3180
6 X 9							
6 X 9 X 2³/₈	112.5	–	10	300	–	2.67	2985



Scan for additional
product information

PEDESTRIAN	LIGHT/REGULAR TRAFFIC	HEAVY TRAFFIC	PERMEABLE	ADA
				
✓	✓			

SHAPES & SIZES

3-Piece



3 x 6 x 2³/₈

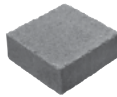

6 x 6 x 2³/₈

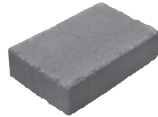

6 x 9 x 2³/₈

6 x 9

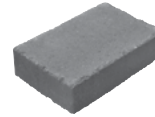

6 x 9 x 2³/₈

UNIT	SQFT/ PALLET	SQFT/ LAYER	LAYER/ PALLET	UNITS/ PALLET	UNITS/ LAYER	UNITS/ SQFT	WEIGHT/ PALLET
------	-----------------	----------------	------------------	------------------	-----------------	----------------	-------------------

3-PIECE

3 X 6 X 2 ³ / ₈	20.79	1.89	–	176	16	8	–
6 X 6 X 2 ³ / ₈	42.57	3.87	–	176	16	4	–
6 X 9 X 2 ³ / ₈	64.35	5.85	–	176	16	2.67	–
TOTAL	128	11.6	11	528	48	–	3445

6 X 9

6 X 9 X 2 ³ / ₈	112.5	11.25	10	300	30	2.67	2970
---------------------------------------	-------	-------	----	-----	----	------	------

NOTES:

AutoCAD® hatch pattern files can be downloaded from belgard.com for use in architectural drawings

Some patterns may not necessarily reflect the percentages of stone sizes within a particular pallet. In some cases you may have extras in one or more of the sizes. This must be accounted for in your planning and design.

Percentages are based on area by paver.

17% 3 x 6 x 2³/₈

33% 6 x 6 x 2³/₈

50% 6 x 9 x 2³/₈

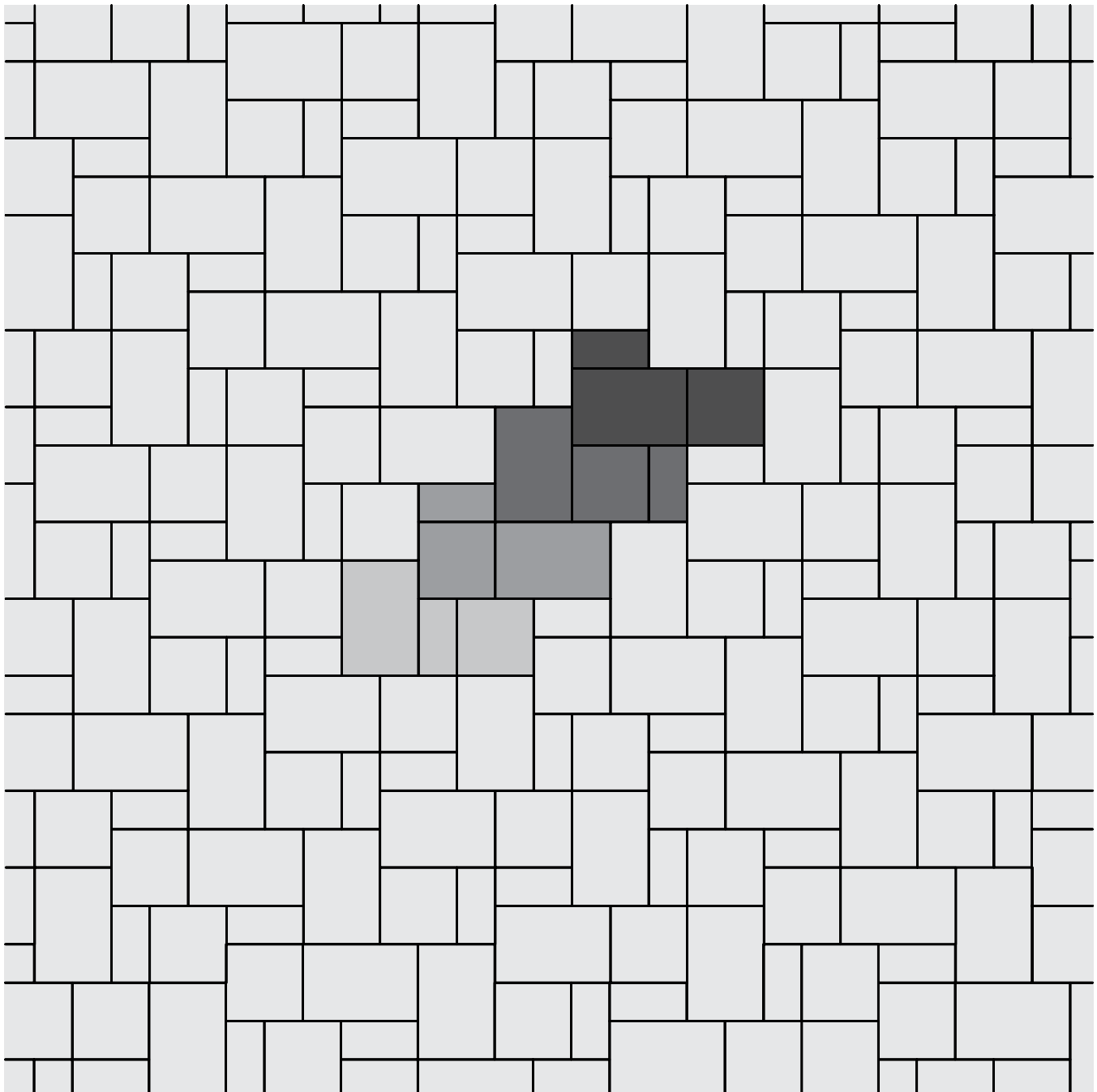

NOTES:

AutoCAD® hatch pattern files can be downloaded from belgard.com for use in architectural drawings

Some patterns may not necessarily reflect the percentages of stone sizes within a particular pallet. In some cases you may have extras in one or more of the sizes. This must be accounted for in your planning and design.

Percentages are based on area by paver.

17% 3 x 6 x 2³/₈

33% 6 x 6 x 2³/₈

50% 6 x 9 x 2³/₈

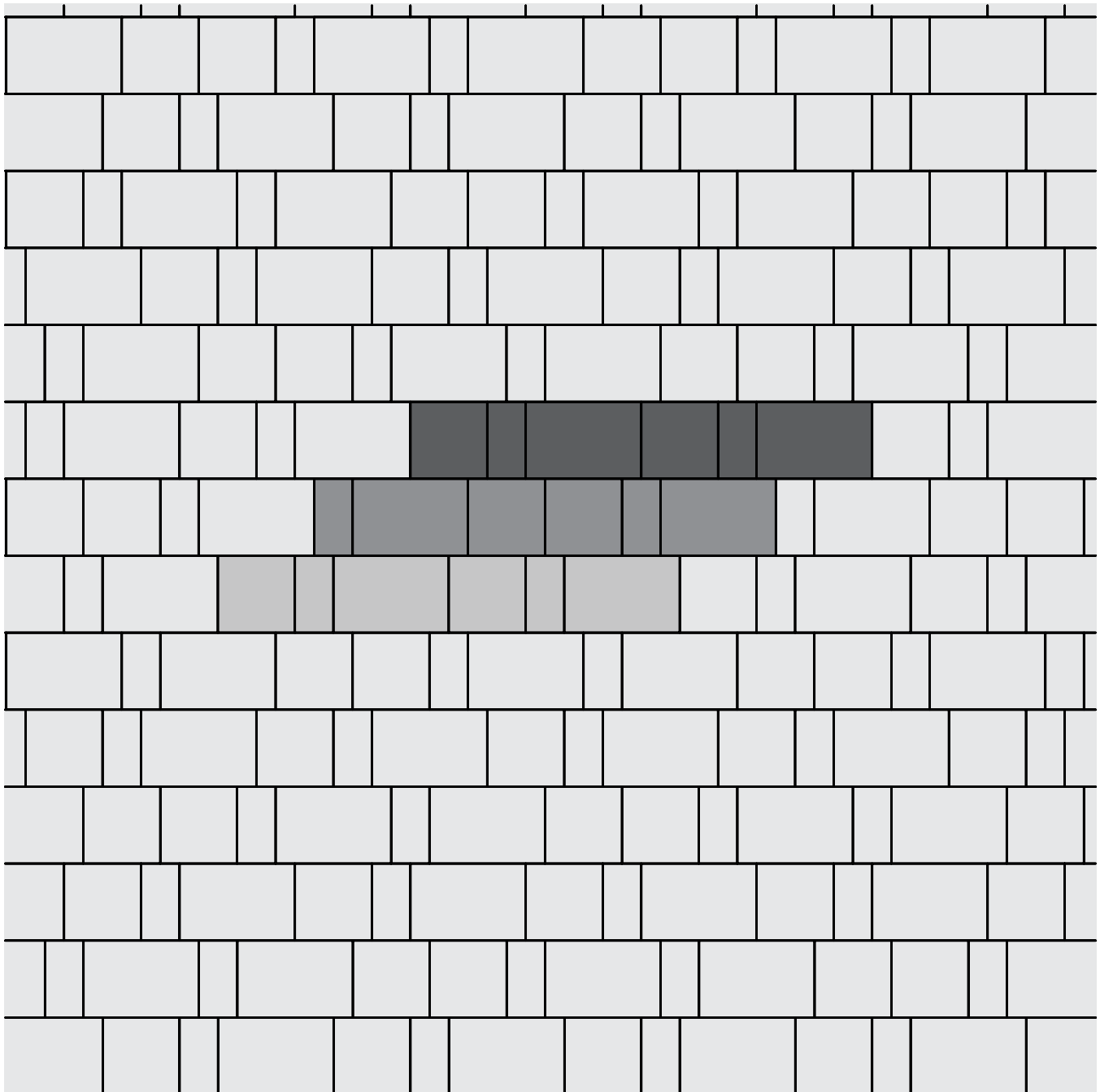



Scan for additional product information

PEDESTRIAN	LIGHT/REGULAR TRAFFIC	HEAVY TRAFFIC	PERMEABLE	ADA
✓	✓	✓*		✓

*80MM only

SHAPES & SIZES

60MM



4 x 8 x 2³/₈

80MM**

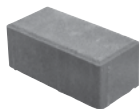

4 x 8 x 3¹/₈

UNIT	SQFT/PALLET	SQFT/LAYER	LAYER/PALLET	UNITS/PALLET	UNITS/LAYER	UNITS/SQFT	WEIGHT/PALLET
60MM							
4 X 8 X 2³/₈	120	12	10	540	54	4.5	3120

Holland Stone 60mm sourced from our Holly Hill production facility is packaged 120 SqFt per pallet, 9 layers per pallet and 13.33 SqFt per layer.

**80mm Holland Stone is available upon special order: Please contact your local Belgard Representative for availability and lead times.

NOTES:

AutoCAD® hatch pattern files can be downloaded from belgard.com for use in architectural drawings

Some patterns may not necessarily reflect the percentages of stone sizes within a particular pallet. In some cases you may have extras in one or more of the sizes. This must be accounted for in your planning and design.

Percentages are based on area by paver.

100% 4 x 8

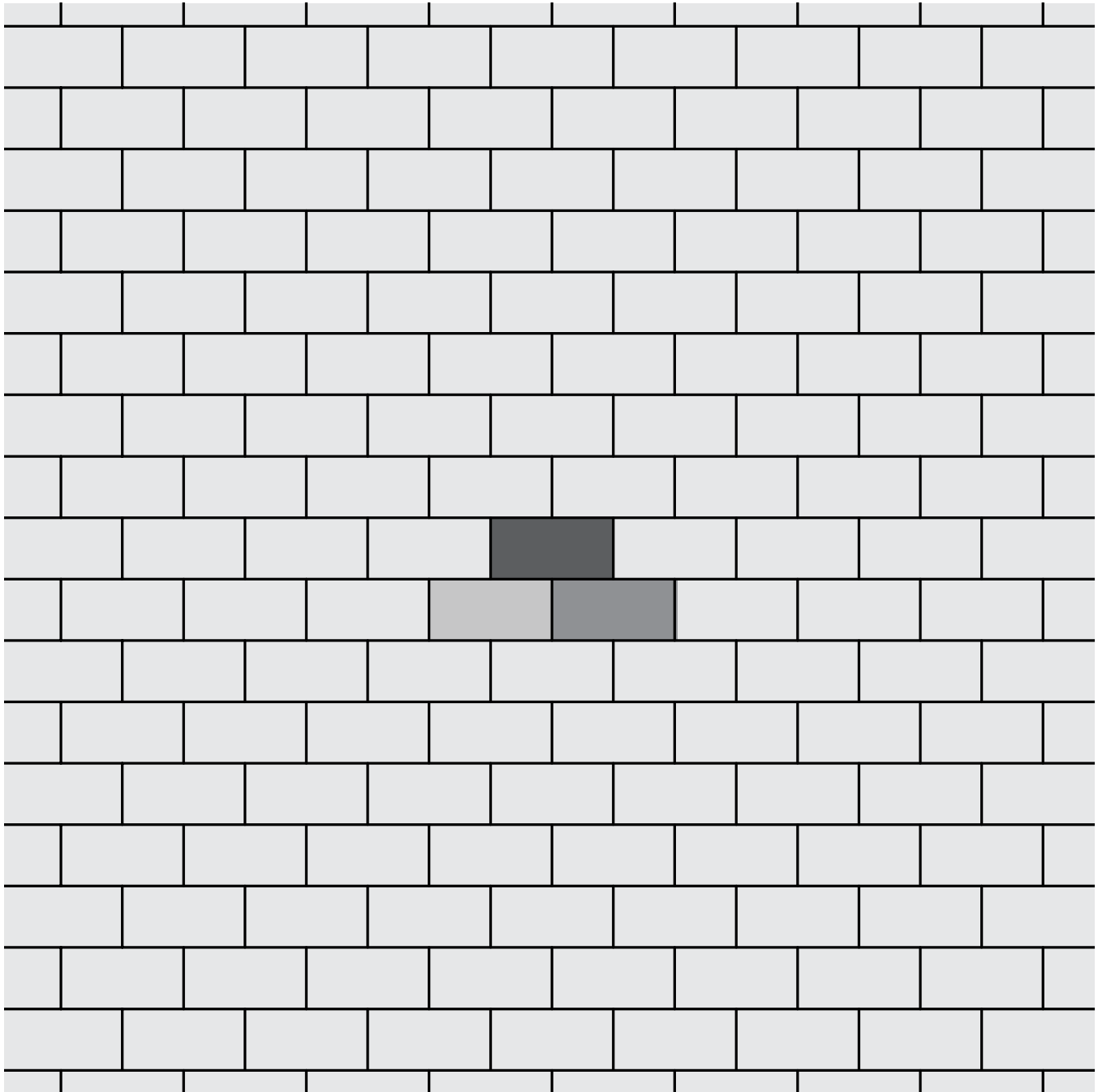

NOTES:

AutoCAD® hatch pattern files can be downloaded from belgard.com for use in architectural drawings

Some patterns may not necessarily reflect the percentages of stone sizes within a particular pallet. In some cases you may have extras in one or more of the sizes. This must be accounted for in your planning and design.

Percentages are based on area by paver.

100% 4 x 8

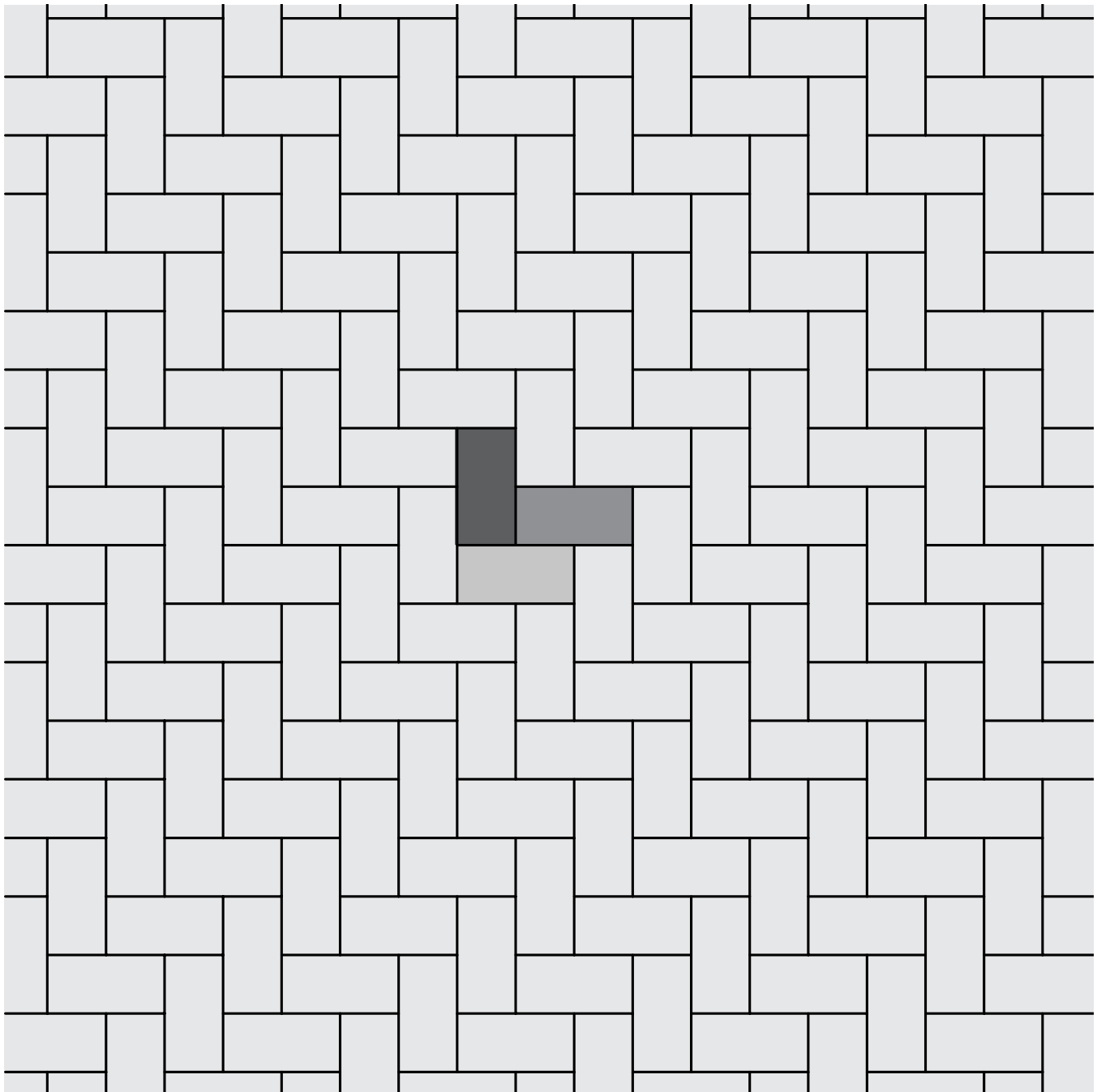

NOTES:

AutoCAD® hatch pattern files can be downloaded from belgard.com for use in architectural drawings

Some patterns may not necessarily reflect the percentages of stone sizes within a particular pallet. In some cases you may have extras in one or more of the sizes. This must be accounted for in your planning and design.

Percentages are based on area by paver.

100% 4 x 8

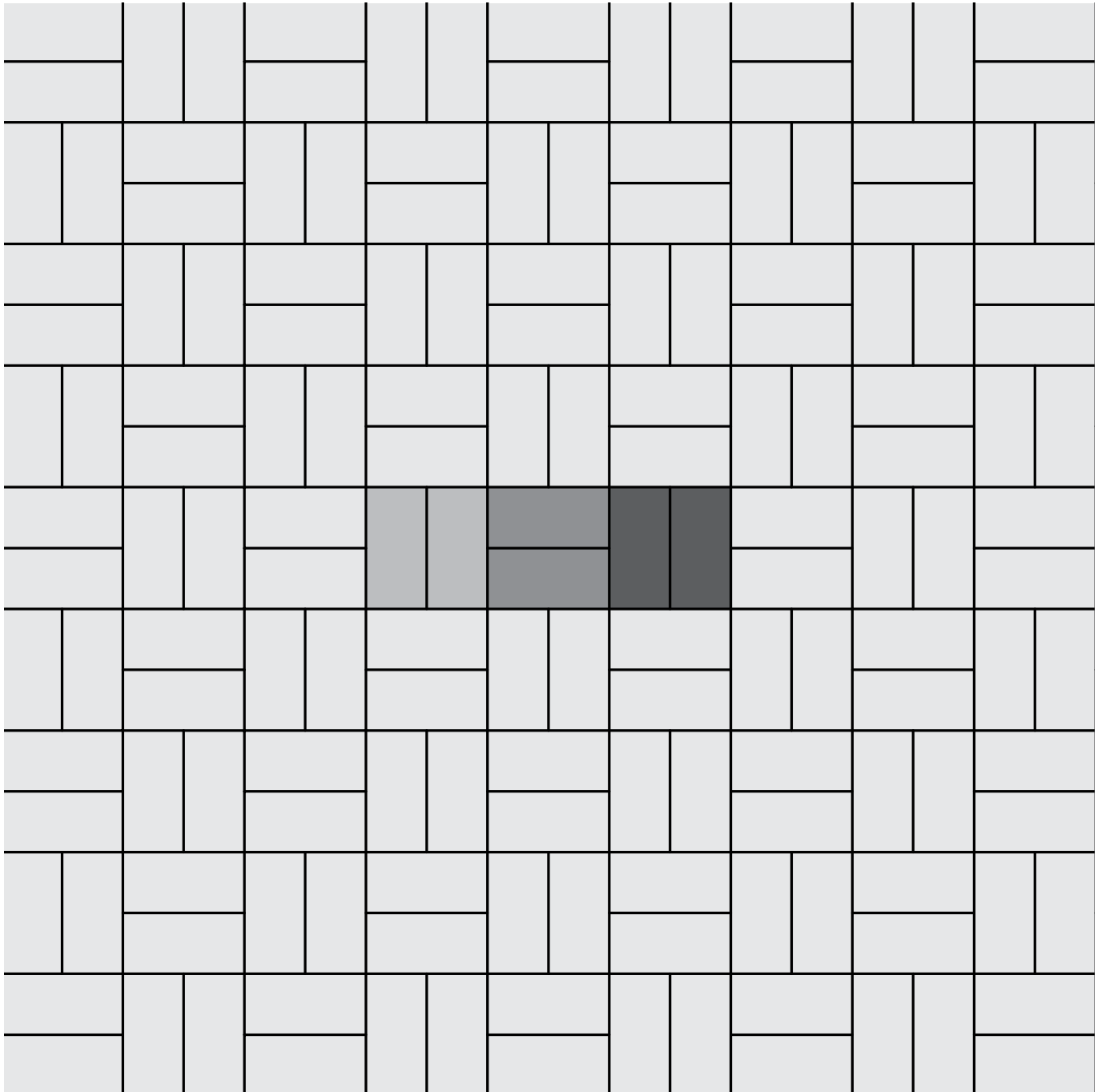





MEGA-ARBEL® PATIO SLAB

NATURAL
COLLECTION 



Scan for additional
product information

PEDESTRIAN	LIGHT/REGULAR TRAFFIC	HEAVY TRAFFIC	PERMEABLE	ADA
				
✓				

SHAPES & SIZES

UNIT



15³/₈ x 21 x 2³/₈

UNIT	SQFT/ PALLET	SQFT/ LAYER	LAYER/ PALLET	UNITS/ PALLET	UNITS/ LAYER	UNITS/ SQFT	WEIGHT/ PALLET
UNIT							
15 ³ / ₈ X 21 X 2 ³ / ₈	104.4	8.7	12	72	6	0.7	2925

MEGA-ARBEL® PATIO SLAB



SAMPLE 1-PIECE CLOVERLEAF PATTERN

NOTES:

AutoCAD® hatch pattern files can be downloaded from belgard.com for use in architectural drawings

Some patterns may not necessarily reflect the percentages of stone sizes within a particular pallet. In some cases you may have extras in one or more of the sizes. This must be accounted for in your planning and design.



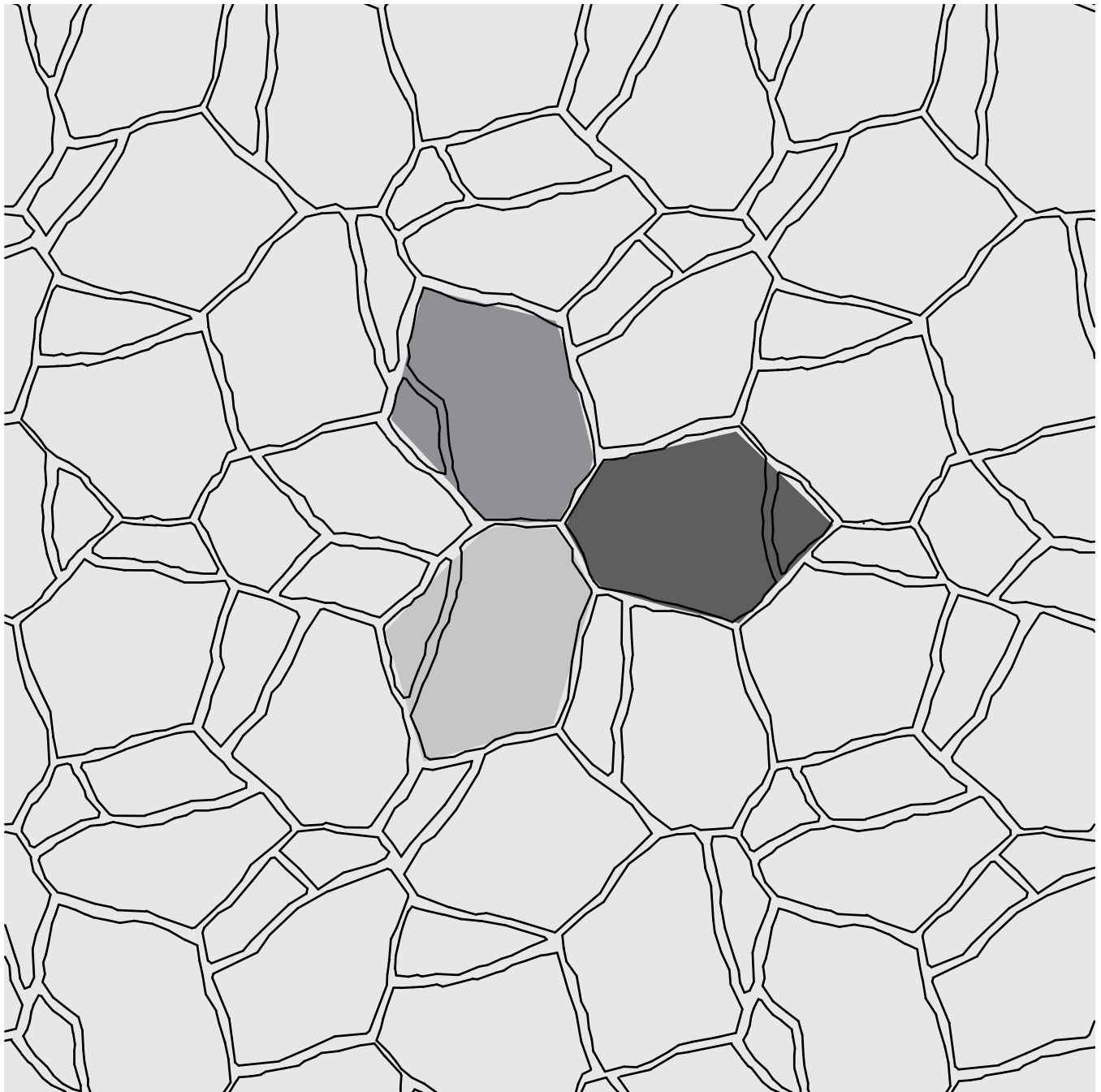

Percentages are based on area by paver.

100% 15³/₈ x 21 x 2³/₈





Scan for additional
product information

PEDESTRIAN	LIGHT/REGULAR TRAFFIC	HEAVY TRAFFIC	PERMEABLE	ADA
				
✓	✓			

SHAPES & SIZES

3-Piece



4³/₄ x 9¹/₂ x 3¹/₈

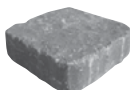

9¹/₂ x 9¹/₂ x 3¹/₈



9¹/₂ x 14¹/₄ x 3¹/₈

UNIT	SQFT/ PALLET	SQFT/ LAYER	LAYER/ PALLET	UNITS/ PALLET	UNITS/ LAYER	UNITS/ SQFT	WEIGHT/ PALLET
3-PIECE							
4 ³ / ₄ X 9 ¹ / ₂ X 3 ¹ / ₈	13.95	1.55	–	45	5	3.21	–
9 ¹ / ₂ X 9 ¹ / ₂ X 3 ¹ / ₈	33.48	3.72	–	54	6	1.61	–
9 ¹ / ₂ X 14 ¹ / ₄ X 3 ¹ / ₈	50.22	5.58	–	54	6	1.08	–
TOTAL	98	10.85	9	153	17	–	3420



NOTES:

AutoCAD® hatch pattern files can be downloaded from belgard.com for use in architectural drawings

Some patterns may not necessarily reflect the percentages of stone sizes within a particular pallet. In some cases you may have extras in one or more of the sizes. This must be accounted for in your planning and design.

Percentages are based on area by paver.

17% $4\frac{3}{4} \times 9\frac{1}{2} \times 3\frac{1}{8}$



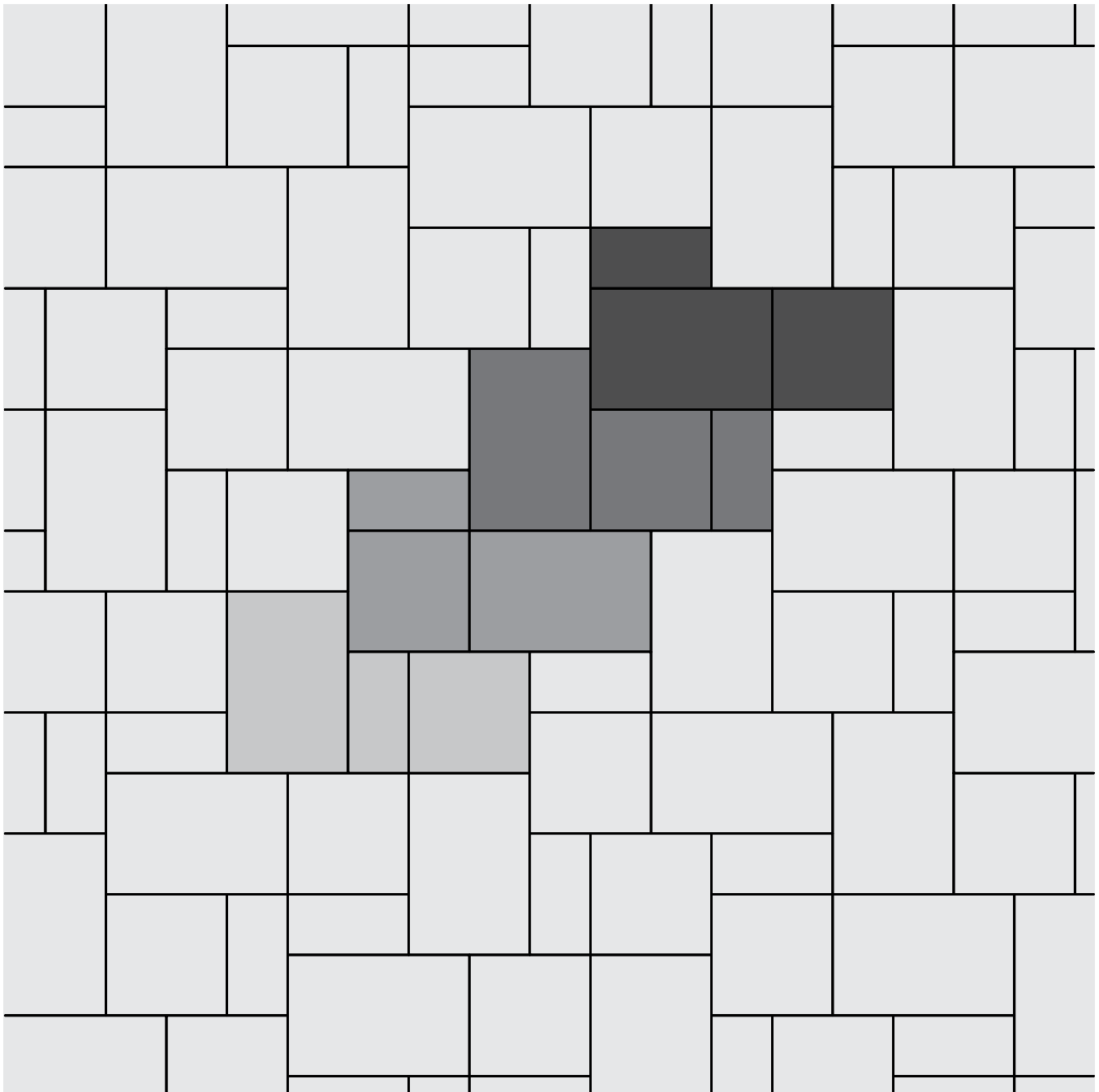

33% $9\frac{1}{2} \times 9\frac{1}{2} \times 3\frac{1}{8}$

50% $9\frac{1}{2} \times 14\frac{1}{4} \times 3\frac{1}{8}$





Scan for additional
product information

PEDESTRIAN	LIGHT/REGULAR TRAFFIC	HEAVY TRAFFIC	PERMEABLE	ADA
				
✓	✓			

SHAPES & SIZES

5 x 10



4¾ x 9½ x 3⅛

UNIT	SQFT/ PALLET	SQFT/ LAYER	LAYER/ PALLET	UNITS/ PALLET	UNITS/ LAYER	UNITS/ SQFT	WEIGHT/ PALLET
5 X 10							
4¾ X 9½ X 3⅛	98	10.9	9	315	5	3.21	3347

NOTES:

AutoCAD® hatch pattern files can be downloaded from belgard.com for use in architectural drawings

Some patterns may not necessarily reflect the percentages of stone sizes within a particular pallet. In some cases you may have extras in one or more of the sizes. This must be accounted for in your planning and design.



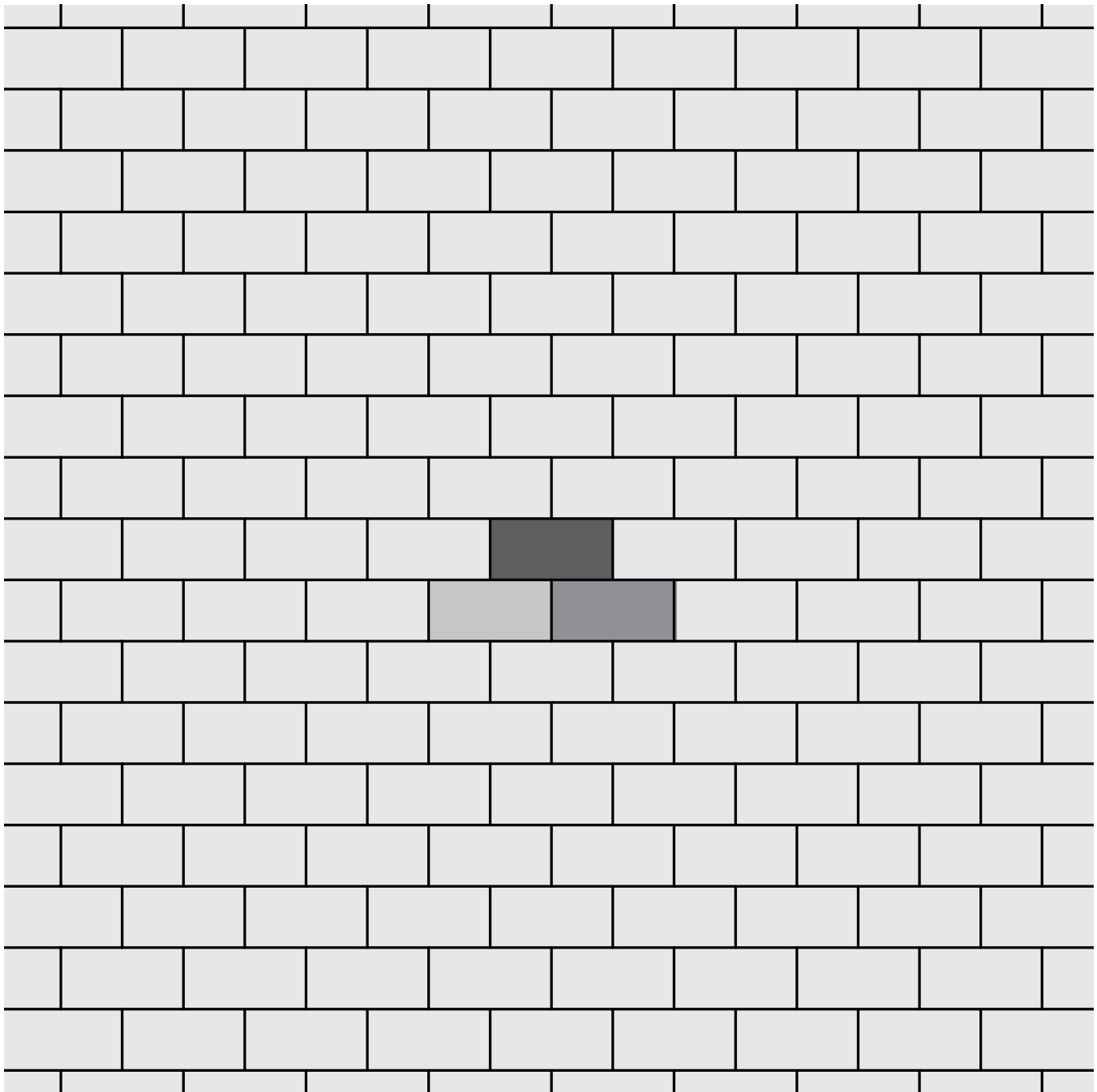

Percentages are based on area by paver.

100% 5 x 10





Scan for additional
product information

PEDESTRIAN	LIGHT/REGULAR TRAFFIC	HEAVY TRAFFIC	PERMEABLE	ADA
				
✓	✓			✓

SHAPES & SIZES

3-Piece

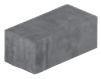

3 x 6 x 2³/₈



6 x 6 x 2³/₈







6 x 9 x 2³/₈

UNIT	SQFT/ PALLET	SQFT/ LAYER	LAYER/ PALLET	UNITS/ PALLET	UNITS/ LAYER	UNITS/ SQFT	WEIGHT/ PALLET
3-PIECE							
3 X 6 X 2³/₈	20	2	–	160	–	8	–
6 X 6 X 2³/₈	40	4	–	160	–	4	–
6 X 9 X 2³/₈	60	6	–	160	–	2.67	–
TOTAL	120	12	10	480	48	–	3312

Please refer to page 11 for laying pattern options.



Scan for additional
product information

PEDESTRIAN	LIGHT/REGULAR TRAFFIC	HEAVY TRAFFIC	PERMEABLE	ADA
				
✓				✓

SHAPES & SIZES

3-Piece



6 x 12 x 2³/₈

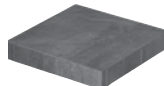

12 x 12 x 2³/₈

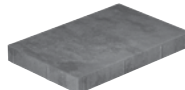





12 x 18 x 2³/₈

UNIT	SQFT/ PALLET	SQFT/ LAYER	LAYER/ PALLET	UNITS/ PALLET	UNITS/ LAYER	UNITS/ SQFT	WEIGHT/ PALLET
3-PIECE							
6 X 12 X 2 ³ / ₈	20	2	–	40	–	2	–
12 X 12 X 2 ³ / ₈	40	4	–	40	–	1	–
12 X 18 X 2 ³ / ₈	60	6	–	40	–	0.66	–
TOTAL	120	12	10	120	12	–	3180

Please refer to page 13-14 for laying pattern options.



Scan for additional
product information

PEDESTRIAN	LIGHT/REGULAR TRAFFIC	HEAVY TRAFFIC	PERMEABLE	ADA
				
✓				✓

SHAPES & SIZES

3-Piece

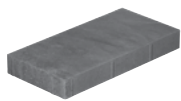

9 x 18 x 2³/₈

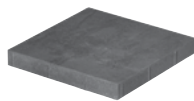

18 x 18 x 2³/₈

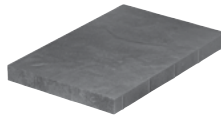





18 x 27 x 2³/₈

UNIT	SQFT/ PALLET	SQFT/ LAYER	LAYER/ PALLET	UNITS/ PALLET	UNITS/ LAYER	UNITS/ SQFT	WEIGHT/ PALLET
3-PIECE							
9 X 18 X 2³/₈	22.5	2.25	–	20	2	0.88	–
18 X 18 X 2³/₈	22.5	2.25	–	10	1	0.44	–
18 X 27 X 2³/₈	67.5	6.75	–	20	2	0.30	–
TOTAL	112.5	11.3	10	50	5	–	2981.3

Please refer to page 16 for laying pattern options.



Scan for additional
product information

PEDESTRIAN	LIGHT/REGULAR TRAFFIC	HEAVY TRAFFIC	PERMEABLE	ADA
				
✓	✓			✓

SHAPES & SIZES

3 x 3



3 x 3 x 2³/₈

3 x 9



3 x 9 x 2³/₈

6 x 6



6 x 6 x 2³/₈

UNIT	SQFT/ PALLET	SQFT/ LAYER	LAYER/ PALLET	UNITS/ PALLET	UNITS/ LAYER	UNITS/ SQFT	WEIGHT/ PALLET
3 X 3							
3 X 3 X 2³/₈	96.25	9.6	10	1540	–	16	2550.6
3 X 9							
3 X 9 X 2³/₈	103.1	10.3	10	550	–	5.33	2732.9
6 X 6							
6 X 6 X 2³/₈	120	12	10	480	–	4	3180



Scan for additional
product information

PEDESTRIAN	LIGHT/REGULAR TRAFFIC	HEAVY TRAFFIC	PERMEABLE	ADA	DURAFUSION PROCESS
✓				✓	✓

SHAPES & SIZES

3-Piece



9 x 18 x 2³/₈



18 x 18 x 2³/₈



18 x 27 x 2³/₈

UNIT	SQFT/ PALLET	SQFT/ LAYER	LAYER/ PALLET	UNITS/ PALLET	UNITS/ LAYER	UNITS/ SQFT	WEIGHT/ PALLET
3-PIECE							
9 X 18 X 2³/₈	22.5	2.25	–	20	2	0.88	–
18 X 18 X 2³/₈	22.5	2.25	–	10	1	0.44	–
18 X 27 X 2³/₈	67.5	6.75	–	20	2	0.30	–
TOTAL	112.5	11.3	10	50	5	–	2981

Please refer to page 16 for laying pattern options.

NOTES:

AutoCAD® hatch pattern files can be downloaded from belgard.com for use in architectural drawings

Some patterns may not necessarily reflect the percentages of stone sizes within a particular pallet. In some cases you may have extras in one or more of the sizes. This must be accounted for in your planning and design.

Percentages are based on area by paver.

3-PIECE PATTERN A

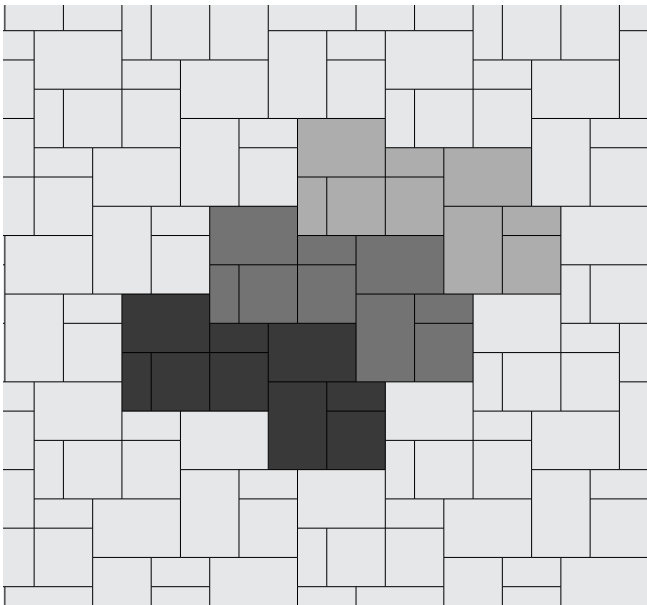

3-PIECE PATTERN B

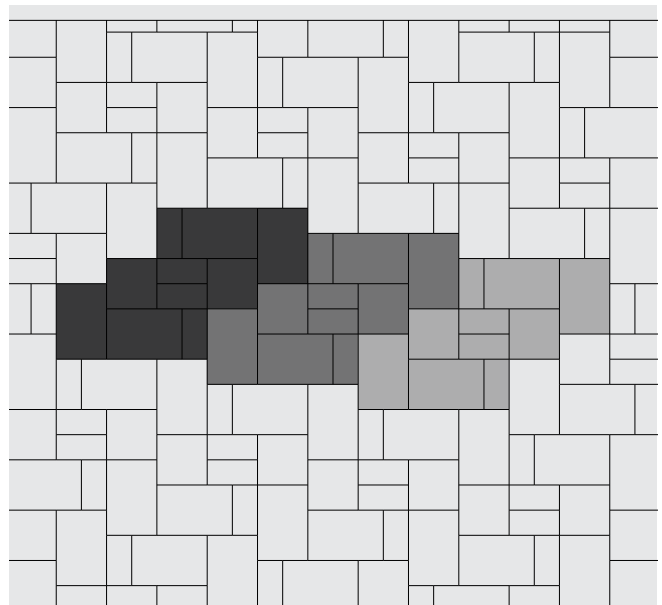



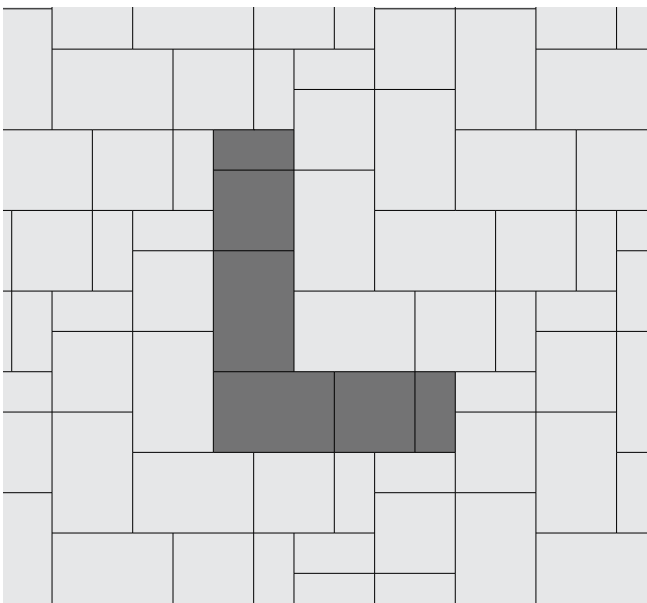



3-PIECE PATTERN C



TRAVERTINO



Scan for additional
product information

PEDESTRIAN	LIGHT/REGULAR TRAFFIC	HEAVY TRAFFIC	PERMEABLE	ADA	DURAFUSION PROCESS
					
✓				✓	✓

SHAPES & SIZES

3-Piece



6 x 12 x 2³/₈

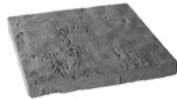

12 x 12 x 2³/₈

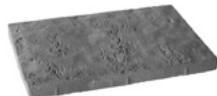

12 x 18 x 2³/₈

UNIT	SQFT/ PALLET	SQFT/ LAYER	LAYER/ PALLET	UNITS/ PALLET	UNITS/ LAYER	UNITS/ SQFT	WEIGHT/ PALLET
3-PIECE							
6 X 12 X 2 ³ / ₈	20	6	–	40	4	2	–
12 X 12 X 2 ³ / ₈	40	4	–	40	4	1	–
12 X 18 X 2 ³ / ₈	60	2	–	40	4	.67	–
TOTAL	120	12	10	120	12	–	3180

ENVIRONMENTAL PAVERS

PERMEABLE PAVER INSTALLATION GUIDE

69 Basic PICP Systems

PERMEABLE PAVER

72 Aqualine™ Series

CONCRETE GRID PAVER

74 Turfstone™

For basic paver installation information
visit icpi.org

PERMEABLE INTERLOCKING CONCRETE PAVEMENT (PICP)

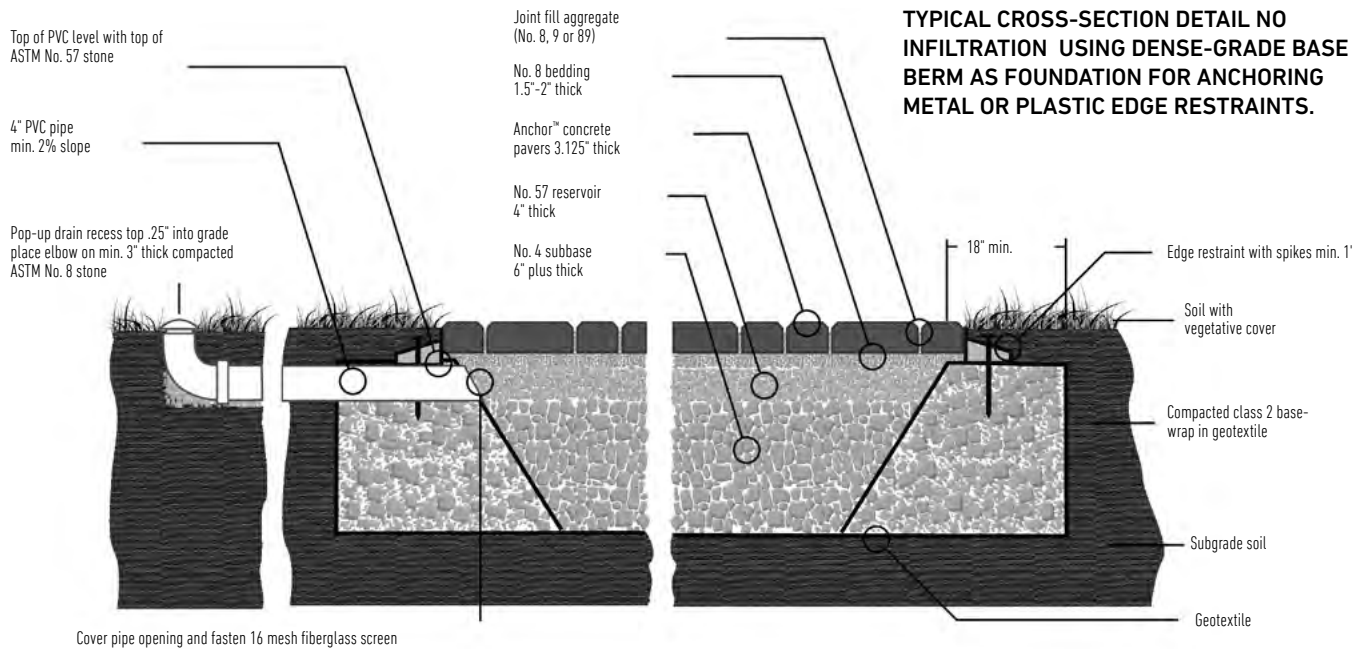

Cover pipe opening and fasten 16 mesh fiberglass screen

INSTALL GEOTEXTILES, IMPERMEABLE LINERS AND DRAIN PIPES IF REQUIRED IN THE PLANS AND SPECIFICATIONS

Geotextiles are used in some permeable pavement applications per the design engineer. If there are no concrete curbs and soil is restraining the sides of the base/subbase at its perimeter, then geotextile should be applied to prevent lateral migration of soil into the base/subbase aggregates. Geotextile is applied vertically against the soil with at least 1 foot (0.3 m) extending horizontally under the subbase and resting on the soil subgrade. A minimum 1-foot (0.3 m) overlap is recommended in stronger subgrade soils and 2-feet (0.6 m) overlap on poor-draining weaker soils (CBR<5%).

Drain pipes are installed according to plans and specifications and should be rigid PVC. Designs should



Use 13,500 lbf (60 kN) plate compactor minimum two passes.

have curb cut-outs or drain pipes from the PICP entering swales or storm sewer catch basins to handle overflow conditions.

Place and compact the aggregate subbase

Subbase material should be spread in minimum 6-inch (150 mm) lifts. Compaction is typically done with a 10 ton (9 T) steel vibratory roller or a 13,500 lbf (60 kN) plate compactor. Greater lift thicknesses are normal (e.g., 12 inch or 0.3 m) when using either of these compactors. When using a roller, the first two passes are in vibratory mode and the last two are in static mode. Compaction is completed when no visible movement can be seen in the base when rolled by the compactor.

INSTALL CURBS OR OTHER EDGE RESTRAINTS

For pedestrian areas and residential driveways, an edge restraint option is using compacted, dense-graded berms around PICP base perimeter with plastic or metal edging fastened to their surface. The dense-graded base is a foundation for metal or plastic edging secured with steel spikes. These edge restraints are installed on the dense-graded berms in a manner identical to those on interlocking concrete pavement driveways. The edge restraint contains some of the bedding layer such that at least the bottom half of the pavers is also contained by the edging.

Place and compact the aggregate base

The ASTM No. 57 base layer is spread and compacted as one 4-inch (100 mm) lift. Like the subbase aggregate, the initial passes with the roller can be with vibration to consolidate the base material or a plate compactor also

can be used to compact the No. 57 base layer. Surface tolerance of the compacted No. 57 stone shall be $\pm \frac{3}{4}$ -inch (19 mm) over a 10 feet (3 m) straight edge.

Place and screed the bedding layer

When subbase and base lifts are compacted the surface should then be topped with a 1½ to 2-inch (50 mm) thick layer of No. 8 crushed stone bedding. This layer is screeded and leveled over the No. 57 base. Metal rails are placed on the compacted No. 57 layer and are used to guide screeding elevations. The surface tolerance of the screeded No. 8 bedding material should be $\pm \frac{3}{8}$ -inch over 10 feet (± 10 mm over 3 m). Install the pavers manually or with mechanical installation equipment.



Manually screeding the No. 8 stone setting bed.

Geotextiles are used in some permeable pavement applications per the design engineer. If there are no concrete curbs and soil is restraining the sides of the base/subbase at its perimeter, then geotextile should be applied to prevent lateral migration of soil into the base/subbase aggregates. Geotextile is applied vertically against the soil with at least 1 foot (0.3 m) extending horizontally under the subbase and resting on the soil subgrade. A minimum 1-foot (0.3 m) overlap is recommended in stronger subgrade soils and 2-feet (0.6 m) overlap on poor-draining weaker soils (CBR<5%).

Drain pipes are installed according to plans and specifications and should be rigid PVC. Designs should have curb cut-outs or drain pipes from the PICP entering swales or storm sewer catch basins to handle overflow conditions.

Place and compact the aggregate subbase

Subbase material should be spread in minimum 6-inch (150 mm) lifts. Compaction is typically done with a 10 ton (9 T) steel vibratory roller or a 13,500 lbf (60 kN) plate compactor. Greater lift thicknesses are normal (e.g., 12 inch or 0.3 m) when using either of these compactors. When using a roller, the first two passes are in vibratory mode and the last two are in static mode. Compaction is completed when no visible movement can be seen in the base when rolled by the compactor.



PICP paver compaction shows that pavers need to be set about $\frac{3}{4}$ -inch (19 mm) above their final elevation before compaction and $\frac{3}{8}$ -inch (10 mm) after compaction to account for downward movement.

After screeding the bedding material, the pavers are placed on this layer. Paver installation can be by hand or with mechanical equipment. Border courses consisting of mostly whole (uncut) pavers are typically used against curbs at PICP edges and at transitions to other pavement surfaces. Paving units abutting border courses should be cut to fill spaces prior to compaction. Cuts should provide gaps around the entire perimeter of the stone that are consistent with the typical joint size — this will allow for proper interlock between units and prevent direct paver-on-paver contact. Cut units should be no smaller than one-third of a whole unit if subject to vehicular traffic.

Fill the paver joints and sweep the surface clean

The paver joints are filled with ASTM No. 8, 9 or 89 stone. Depending on the PICP area, spreading and sweeping can be done with shovels and brooms, or larger areas with machines, sweeping into the paver joints with powered brooms or sweepers. Once the joints are full (within $\frac{1}{4}$ -inch or 6 mm of the paver surface), the surface must be swept clean prior to compaction as loose stones on the surface can mar the pavers when in contact with a plate compactor.

Compact the pavers

After the PICP surface is swept clean, compact it with a plate compactor. Make a minimum of two passes with the second pass in a perpendicular direction from the first pass. The plate compactor should exert a minimum 5,000 lbf (22 kN) at 75-90 Hz.

Top up joints with joint filling stone as needed and sweep the surface clean

Compaction can cause some settlement of the aggregates inside the joints. If the aggregates are more than ¼-inch (6 mm) from the paver surface, they should be topped up to this level with additional aggregates.





**Additional resources and technical specifications online at www.icpi.org.
Source: ICPI Tech Spec, issue number 18**

AQUALINE™ SERIES



Scan for additional product information

Mechanical Installation Available 
Please contact your local Belgard Representative for more info.

PEDESTRIAN	LIGHT/REGULAR TRAFFIC	HEAVY TRAFFIC	PERMEABLE	ADA
				
✓	✓	✓	✓	✓

SHAPES & SIZES

3-Piece

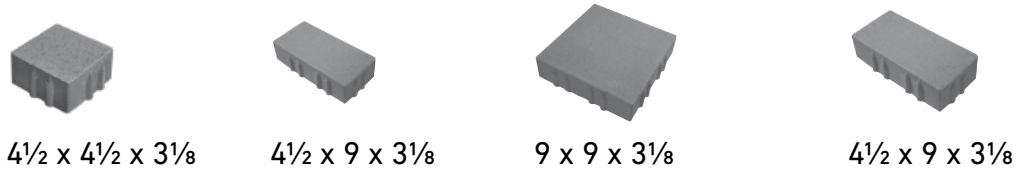

4 1/2 x 4 1/2 x 3/8

4 1/2 x 9 x 3/8

9 x 9 x 3/8

4 1/2 x 9 x 3/8

UNIT	SQFT/PALLET	SQFT/LAYER	LAYER/PALLET	UNITS/PALLET	UNITS/LAYER	UNITS/SQFT	WEIGHT/PALLET
------	-------------	------------	--------------	--------------	-------------	------------	---------------

3-PIECE

4 1/2 X 4 1/2 X 3/8	20.30	2.538	–	144	18	7.11	–
4 1/2 X 9 X 3/8	47.21	5.901	–	168	21	3.56	–
9 X 9 X 3/8	22.48	2.81	–	40	5	1.77	–
TOTAL	90	11.25	8	352	44	–	3150

4 1/2 X 9

4 1/2 X 9 X 3/8	90	11.25	8	320	40	3.56	3105
-----------------	----	-------	---	-----	----	------	------

NOTES:

AutoCAD® hatch pattern files can be downloaded from belgard.com for use in architectural drawings

Some patterns may not necessarily reflect the percentages of stone sizes within a particular pallet. In some cases you may have extras in one or more of the sizes. This must be accounted for in your planning and design.

Percentages are based on area by paver.

3-PIECE PATTERN A

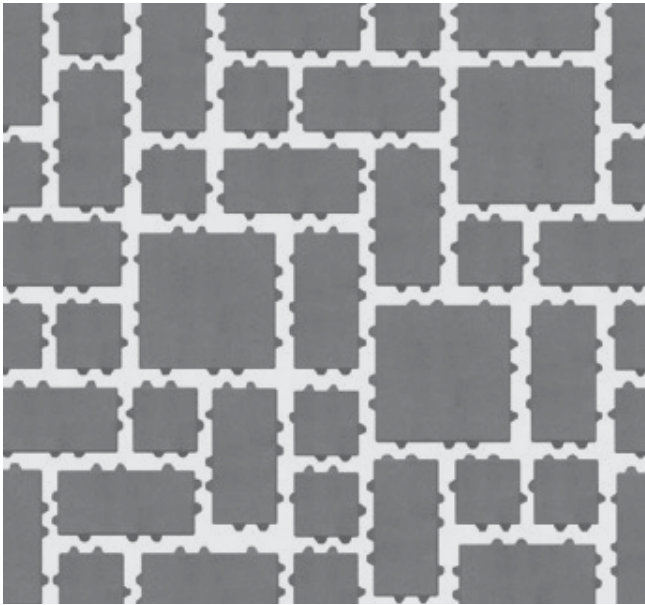

1-PIECE HERRINGBONE

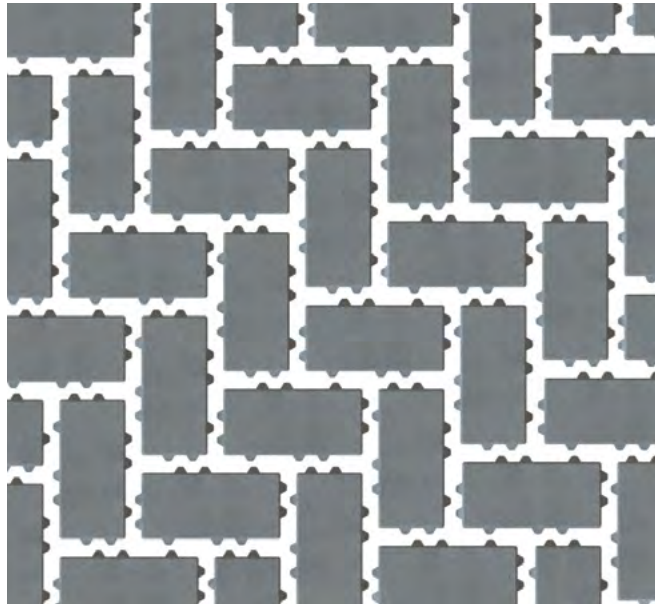



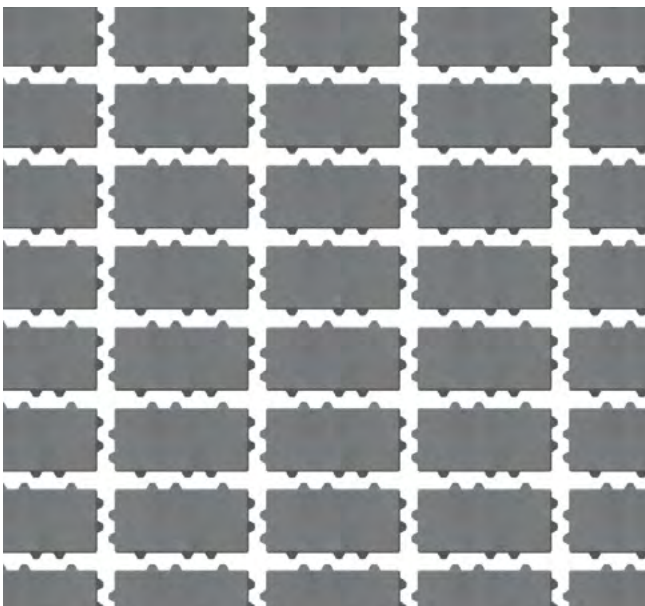

1-PIECE STACKBOND





Scan for additional
product information

PEDESTRIAN	LIGHT/REGULAR TRAFFIC	HEAVY TRAFFIC	PERMEABLE	ADA
				
✓	✓			

SHAPES & SIZES

Unit



15³/₄ x 23⁵/₈ x 3¹/₈

UNIT	SQFT/ PALLET	SQFT/ LAYER	LAYER/ PALLET	UNITS/ PALLET	UNITS/ LAYER	UNITS/ SQFT	WEIGHT/ PALLET
UNIT							
15 ³ / ₄ X 23 ⁵ / ₈ X 3 ¹ / ₈	128	12.8	10	50	5	0.39	3000



NOTES:

AutoCAD® hatch pattern files can be downloaded from belgard.com for use in architectural drawings

Some patterns may not necessarily reflect the percentages of stone sizes within a particular pallet. In some cases you may have extras in one or more of the sizes. This must be accounted for in your planning and design.

Percentages are based on area by paver.

100% 15³/₄ x 23⁵/₈ Units

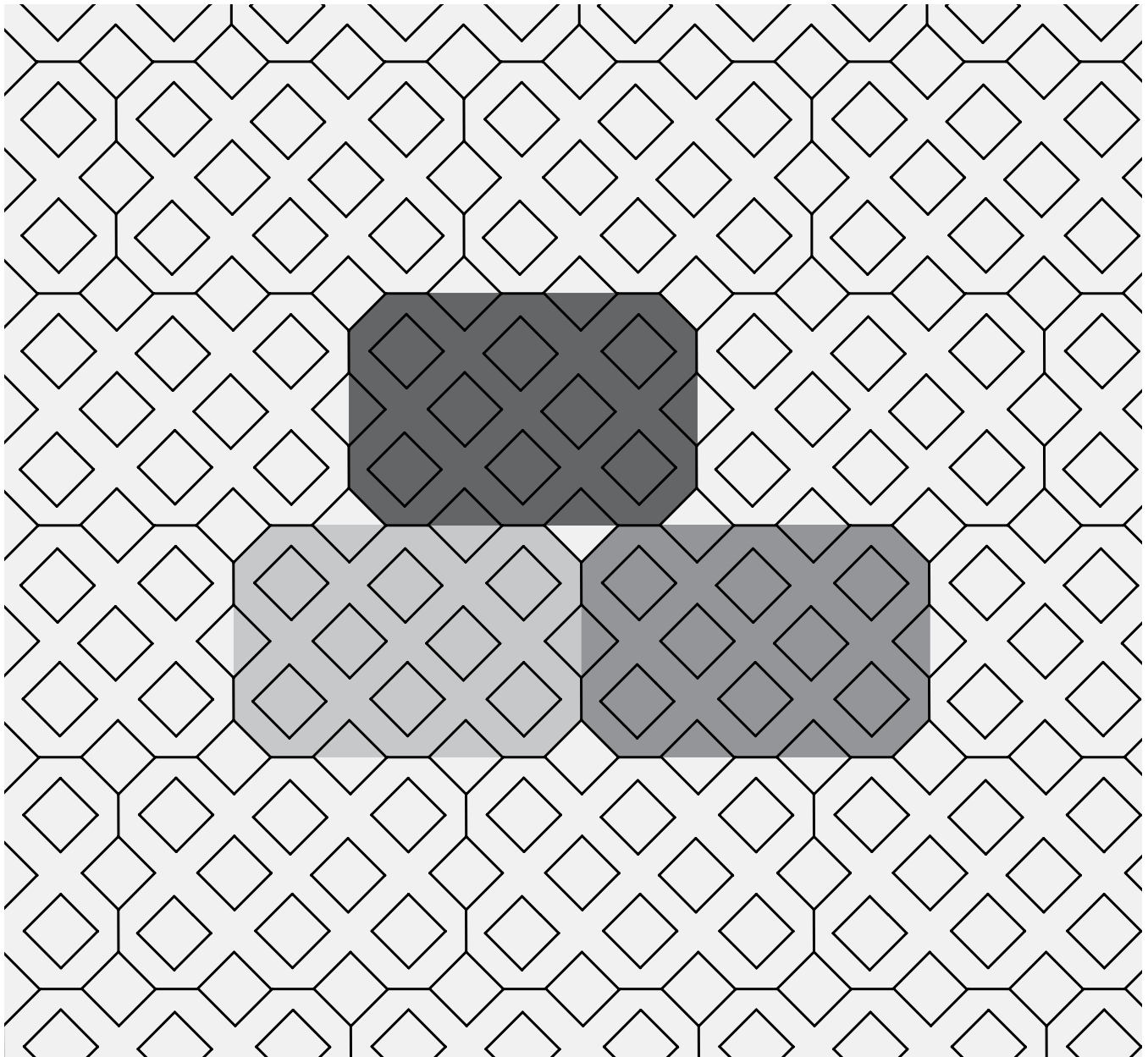

PORCELAIN PAVERS & PLANKS

PORCELAIN INSTALLATION GUIDE

- 77 Porcelain Paver Advantages
- 77 Specialty Tools for Porcelain Pavers Construction
- 78 Cleaning & Maintenance For Porcelain Products
- 78 Porcelain Paver Installation
- 79 Sand Set over Compacted Road Base Installation (Pedestrian Foot Traffic)
- 79 Sand Set over Concrete Overlay Installation (Pedestrian Foot Traffic)
- 80 Gravel Set Installation
- 80 Cementitious Adhesive Overlay, Concrete Base Installation (Light Vehicular Traffic)

PORCELAIN PAVERS & PLANKS

- 82 Foundation™
- 83 Genoa™
- 84 Noon
- 85 Quarziti 2.0

For basic paver installation information
visit Belgard.com/resources

PORCELAIN PAVERS

Belgard Porcelain Pavers are formed by pressing, followed by vitrification: this process involves the total fusion into a single material made from natural raw materials (sand, quartz, feldspars, kaolin, clays and inorganic pigments) which, fired at temperatures above 1226.67° C (2240° F), are transformed into a product with exceptional hardness, ultra-low absorption rate and unmatched mechanical characteristics. Belgard porcelain pavers are eco-compatible and ecolabel-certified. Each unit is 20mm (0.7874") standard thickness or ¾" nominal thickness and is durable enough to withstand use in exterior applications.

PORCELAIN PAVERS ADVANTAGES:

- **Freeze thaw resistant**—They are 100% frost-free and their properties remain unaltered at temperatures ranging from -51.1° to + 60° C (-60° F to +140°F).
- **Color durability**—Color is fused by vitrification, becomes an integral part of the porcelain surface and is not affected by elements.
- **Easy installation**—Perfect fit and for fast installs.
- **Low absorption rate**—Spills, salt and other materials will not seep into pours.
- **Easy to clean**—Household cleaners can be used to wipe down spills and dirt; can even be pressure washed with a low pressure washing device* (see pressure washing warning below).*
- **Stylish**—Matches what homeowners are currently doing inside the home.
- **Durable**—High breakage loads of up to 3,587 lbs (1,627 kg) per foot based on ASTM-C648.
- **Resistant**— High compressive strength and ultra-low absorption rate creates a dense surface that resists mold, moss, dirt and other staining.
- **Skid-resistant**—Structured paver top textures create slip resistant surfaces for safety; perfect for around pools/spas or in wet climates.
- **Modular Design**—Superior accuracy in dimensional sizing and linear sides, the slabs allow for perfectly executed installations with tight and accurate lines.
- **Light weight**—16.8 kg (37 lbs) for the 24"x24" paver permit for easy installation, removal and serviceability and even reusability (Excluding adhered installations).
- Available in colors that have an SRI that qualifies for a LEED certification. The SRI on some units ranges between 60-80. To receive LEED credit, the SRI must be at least 29.
- **Impermeable**— Deicing salt and other deicing materials can be used without concern of damage.

* It is important that all pressure washing of your porcelain pavers be done with a low pressure washer with a maximum of 1600 psi and nothing more powerful. When pressure washing your installation, care should be taken to prevent damage to the grout (adhesive and grout installations) and some re-sanding will be necessary when power washing an installation with sand or polymeric sand joints.

SPECIALTY TOOLS FOR PORCELAIN PAVER CONSTRUCTION:

- Wet cut tile saw equipped with a diamond blade manufactured for wet cutting porcelain. The saw should be designed to safely cut a 24 inch length porcelain paver.
- A paver clamp for easy handling, which can be used to both install and remove pavers.
- The use of gloves is highly recommended while handling and installing porcelain slabs.
- Appropriate notched trowels and grout float tools for cementitious adhesive and grout installation. The appropriate tool selection would be based on the adhesive and grout manufacturer's recommendation
- Pallets of porcelain pavers are manufactured and shipped with a Heavy Duty plastic protective pallet cover and the individual porcelain pavers are packaged in protective cardboard boxes. To prevent damage to your pavers, do not remove the protective cardboard boxes until you are ready to install them.
- Caution: Removing pavers from their protective packaging and handling multiple loose stones together creates the possibility for chipping.

Once the Heavy Duty plastic pallet covers have been removed from the pallet, the unused boxed pavers should be protected from the elements to insure the integrity of the protective cardboard boxes.

CLEANING & MAINTENANCE FOR PORCELAIN PRODUCTS

Post-laying cleaning is obligatory after on site works. Inadequate or late removal of the grouting used on the joints can leave marks difficult to remove and create, on the flooring, a cement film able to absorb all types of dirt, thus giving the impression that it is the material that has become dirty.

It is indispensable to dissolve and remove these residues completely using buffered acids diluted in water (follow the instructions on the packs of the products used), which must then be removed completely and quickly, rinsing the floor with plenty of water to avoid residues or drops on the floor which could damage the tiles.

Allow the product to act on the wet floor, without letting it dry and rubbing it with colorless rags. Next, rinse it thoroughly with water to ensure that the floor is free of detergent residues. If necessary, repeat the operation.

We suggest performing a preliminary wash on a sample surface of a few square meters; if the test is successful, extend clearing over the entire surface. When you have done the above wash, carry out a basic or alkaline wash using degreasing detergents. This is because acid can leave grease on the floor, which could contribute to retaining dirt.

PORCELAIN PAVER INSTALLATION

Each of the following option details will include specific information relative to the selected installation. Base thicknesses vary between different geographical and climatic locations and the contractor will be installing typical base thicknesses for paving installations in their location.

Installing porcelain pavers requires the bedding course sand to be pre-compacted and then struck off with a screed to the required thickness as shown in the detail drawings. The porcelain pavers are not compacted and therefore the sand layer beneath them requires pre-compaction. Do not compact dry sand, but insure the sand has a 5 to 6% moisture content so that it will compact cohesively and allow for a smooth strike off finish.

INSTALLATION INFORMATION THAT MUST BE FOLLOWED :

- NEVER compact porcelain pavers with a plate compactor.
- ALWAYS pre-compact and strike off your sand leveling course before installing your porcelain pavers in sand set installations.
- Porcelain pavers should only be wet cut with a tile saw equipped with a wet cut porcelain blade.
- NEVER install porcelain pavers without the required 4mm spacing between them. The porcelain pavers should never be installed with a porcelain to porcelain contact. Plastic 4mm spacers (shown at right) should be used on Sand Set and Permeable installations. The photo on the left illustrates the spacer installed in a perspective to support and space 4 paver corners and the photo on the right illustrates the installed spacer snapped apart (as designed) to form Space T that supports 2 paver corners. This versatility will permit your porcelain pavers to be installed in a stack bond pattern, a running bond patterns as well as a flush installation against another structure.
- For a 100 sf. project, approximately 34 spacers are needed; this allows for overages if needed.

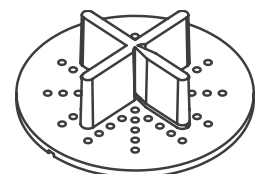

4mm spacers

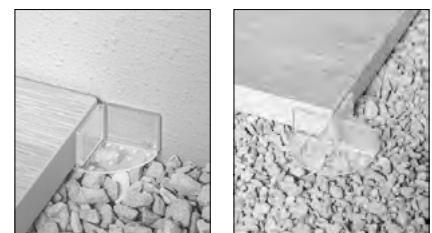

SAND SET OVER COMPACTED ROAD BASE INSTALLATION (PEDESTRIAN FOOT TRAFFIC)

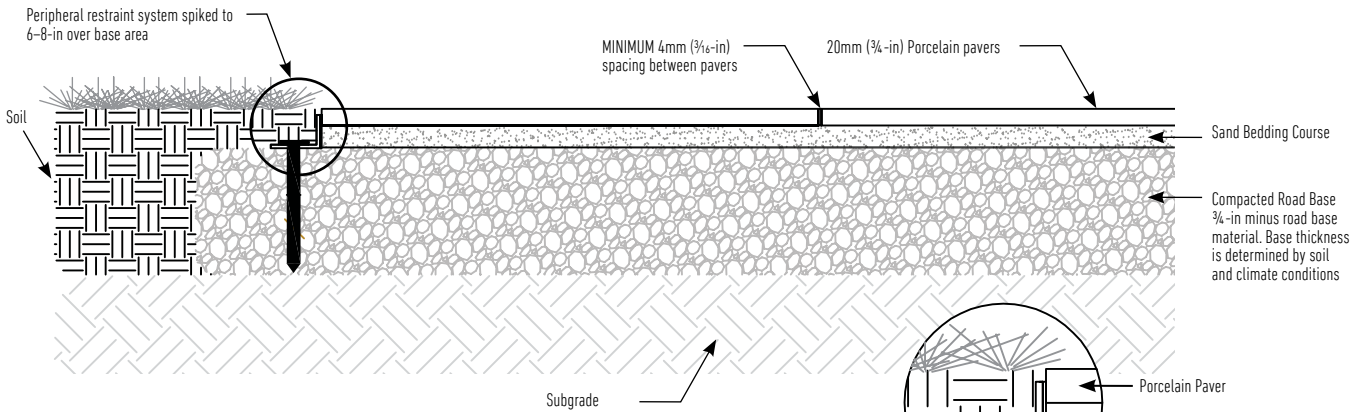

INSTALLATION NOTES:

- Follow the detailed drawing above
- Base material is to be over based 6 to 8 inches beyond the edge of the pavement.
- Precompact the sand bedding course and screed to 1-in thickness with smooth surface
- The required edge restraint system is a low profile edge restraint with a vertical height of 1 1/2-in as shown in the drawing.
- Insure that pavement is constructed with a 1 1/2 to 2% slope that it is pitched away from any building.
- Insure the plastic 4mm spacers are installed at all corners of the installed pavers.

Belgard porcelain pavers can also be installed as a permeable system. Replace sand with 2 inch thick bedding course or 3/8 inch crushed open grade aggregate. Replace 3/4 minus base with 3/4 crushed open grade aggregate

SAND SET OVER CONCRETE OVERLAY INSTALLATION (PEDESTRIAN FOOT TRAFFIC)

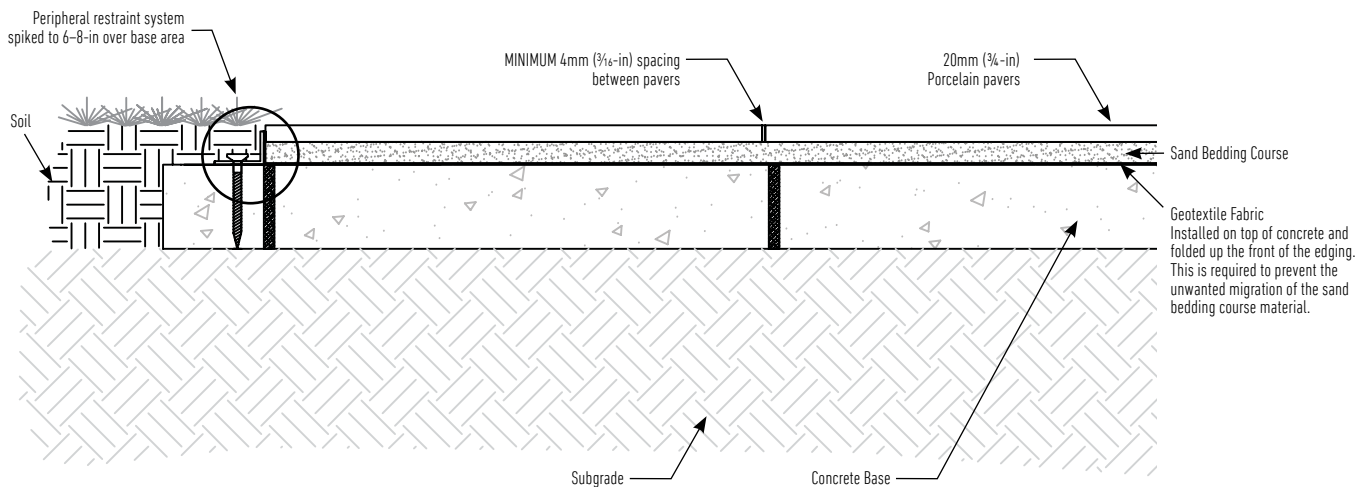

INSTALLATION NOTES:

- The required edge restraint system is a low profile edge restraint with a vertical height of 1 1/2 inches as shown in the drawing.
- Precompact the sand bedding course and screed to 1-in thickness with smooth surface
- Mechanically anchor edge restraint into the concrete base.
- Insure geotextile is installed directly on top of the concrete to contain the bedding sand.
- Insure that pavement is constructed with a 1 1/2 to 2 percent slope and that it is pitched away from any building.
- Insure the plastic 4mm spacers are installed at all corners of the installed pavers.

GRAVEL SET OVER OPEN GRADED AGGREGATE INSTALLATION

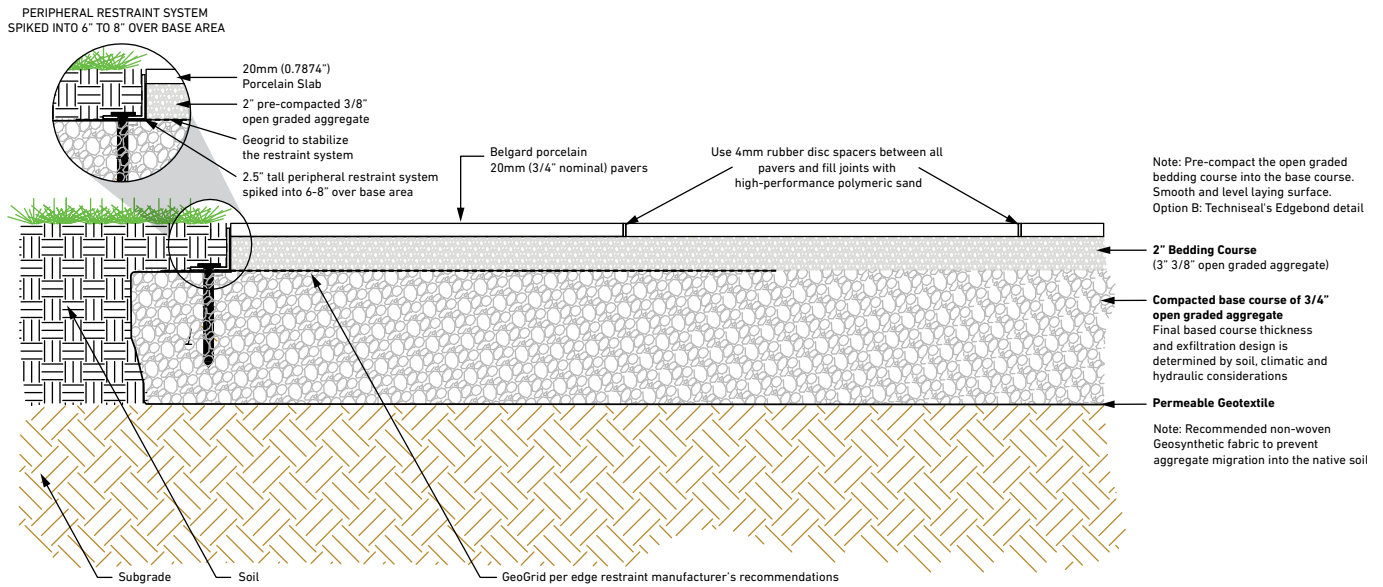

INSTALLATION NOTES:

- Weather, soil type and job conditions should be considered when choosing the best installation method. Follow the detail drawing.
- The required edge restraint system for this installation has a vertical height of 2½ inches as shown in the drawing. Follow the edge restraint manufacturer's recommendations for the use of their product in permeable applications regarding geogrid usage and placement to maintain the performance of there edging.
- Ensure that pavement is constructed with a 2% slope and that it is pitched away from any building.
- Ensure the 4mm spacers are installed between all pavers.
- The open-graded aggregate should be clean and free from foreign matter, manufactured from crushed rock and conform to ASTM C33 size No. 57. Do not use recycled aggregates or rounded river gravel.
- Additional Drainage: If the project has fine-grained soils, silts or clays, and contributing water sources such as downspouts or groundwater, it is important to install a perforated pipe underdrain to prevent saturation of the subgrade. Make sure underdrain has an acceptable discharge location.
- When installing porcelain planks (12 x 48 & 8 x 48), always lay the pattern of 1/3's. These should not be placed next to each other at 50%.
- Roller Compactor recommended for all compaction with Porcelain products

CEMENTITIOUS ADHESIVE OVERLAY, CONCRETE BASE INSTALLATION (LIGHT VEHICULAR TRAFFIC)

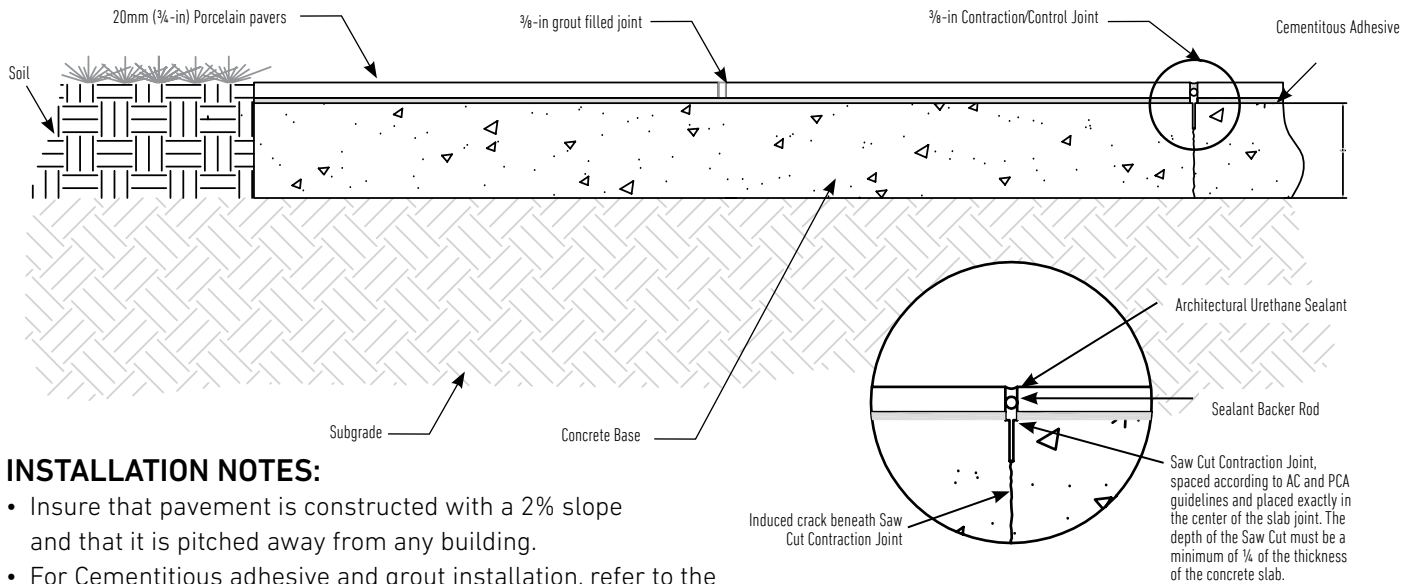

INSTALLATION NOTES:





- Insure that pavement is constructed with a 2% slope and that it is pitched away from any building.
- For Cementitious adhesive and grout installation, refer to the manufacturer's technical instructions and specifically as they relate to outdoor installations.
- For concrete foundation slabs that are not large enough to require contraction / control joints, a minimum 4mm (1/8" to 3/16") grout joint is acceptable, but for larger concrete foundation slabs that do require contraction / control joints, the joint width should be a 3/8". It is absolutely imperative that all contraction / control joints be located in the joint line of installed porcelain pavers and not beneath a paver.
- Caution: If a Porcelain Paver is installed over a control joint, the paver will reflectively crack along the contraction / control joint beneath it.

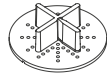

Scan for additional
product information



Spacers are recommended for all porcelain paver installations.
PLEASE NOTE: For vehicular applications, must be a mortar install over a concrete slab.

PEDESTRIAN	LIGHT/REGULAR TRAFFIC	HEAVY TRAFFIC	PERMEABLE	ADA
				
✓	✓*			✓

*Special installation method required, contact your Belgard rep for more information.

SHAPES & SIZES

24 x 24



24 x 24 x 3/4





UNIT	SQFT/ PALLET	SQFT/ BOX	BOXES/ PALLET	UNITS/ BOX	UNITS/ LAYER	UNITS/ SQFT	WEIGHT/ PALLET
24 X 24							
24 X 24 X 3/4	275.04	7.64	36	2	–	.25	2533.8

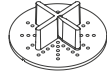

Scan for additional
product information



Spacers are recommended for all porcelain paver installations.
PLEASE NOTE: For vehicular applications, must be a mortar install over a concrete slab.

PEDESTRIAN	LIGHT/REGULAR TRAFFIC	HEAVY TRAFFIC	PERMEABLE	ADA
				
✓	✓*			✓

*Special installation method required, contact your Belgard rep for more information.

SHAPES & SIZES

12 x 24

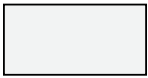

11.73 x 23.54 x 3/4

24 x 24



24 x 24 x 3/4





UNIT	SQFT/ PALLET	SQFT/ BOX	BOXES/ PALLET	UNITS/ BOX	UNITS/ LAYER	UNITS/ SQFT	WEIGHT/ PALLET
UNIT 12 X 24							
11.73 X 23.54 X 3/4	303.6	7.59	40	4	–	.5	2807
UNIT 24 X 24							
24 X 24 X 3/4	275.04	7.64	36	2	–	.25	2533.8

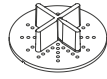

Scan for additional product information



Spacers are recommended for all porcelain paver installations.
PLEASE NOTE: For vehicular applications, must be a mortar install over a concrete slab.
Please refer to the MIRAGE install guide for driveway install procedure.

PEDESTRIAN	LIGHT/REGULAR TRAFFIC	HEAVY TRAFFIC	PERMEABLE	ADA
				
✓	✓*			✓

*Special installation method required, contact your Belgard rep for more information.

SHAPES & SIZES

8 x 48

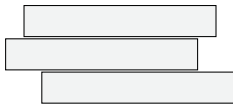

7.64 x 47.17 x 3/4

UNIT	SQFT/ PALLET	SQFT/ BOX	BOXES/ PALLET	UNITS/ BOX	UNITS/ LAYER	WEIGHT/ LAYER	WEIGHT/ PALLET
UNIT 8 X 48							
7.64 X 47.17 X 3/4	151.8	5.06	30	2	-	-	1380

QUARZITI 2.0





PORCELAIN
COLLECTION 

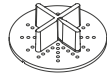

Scan for additional
product information



Spacers are recommended for all porcelain paver installations.
PLEASE NOTE: For vehicular applications, must be a mortar install over a concrete slab.
Please refer to the MIRAGE install guide for driveway install procedure.

PEDESTRIAN	LIGHT/REGULAR TRAFFIC	HEAVY TRAFFIC	PERMEABLE	ADA
				
✓	✓*			✓

*Special installation method required, contact your Belgard rep for more information.

SHAPES & SIZES

24 x 24



23.54 x 23.54 x 3/4

UNIT	SQFT/ PALLET	SQFT/ BOX	BOXES/ PALLET	UNITS/ BOX	UNITS/ LAYER	WEIGHT/ LAYER	WEIGHT/ PALLET
24 X 24							
23.54 X 23.54 X 3/4	232.5	7.75	30	2	-	-	2160

MIRAGE[®]
INSPIRING BETTER LIVING

WALLS

WALL INSTALLATION GUIDE

- 87 Wall Types
- 88 Before You Begin

WALLS

- 106 Ashlar Tandem™
- 122 Castlemanor® Grana
- 123 Diamond Pro®
- 124 Highland Stone®
- 125 Melville Tandem™
- 126 Melville™ Wall
- 127 Weston Stone™

For basic wall installation information
visit Belgard.com/resources

SEGMENTAL RETAINING WALL TYPES

Segmental retaining walls typically fall into one of three categories.

GRAVITY RETAINING WALL

The first category — a gravity wall — is a retaining wall that does not use soil reinforcement. A gravity wall has height limitations specific to each product and project. An advantage of this type of retaining wall is that it requires a smaller work area behind the wall. A gravity wall relies on the weight, depth and setback of the block to resist the soil forces being exerted on the wall.

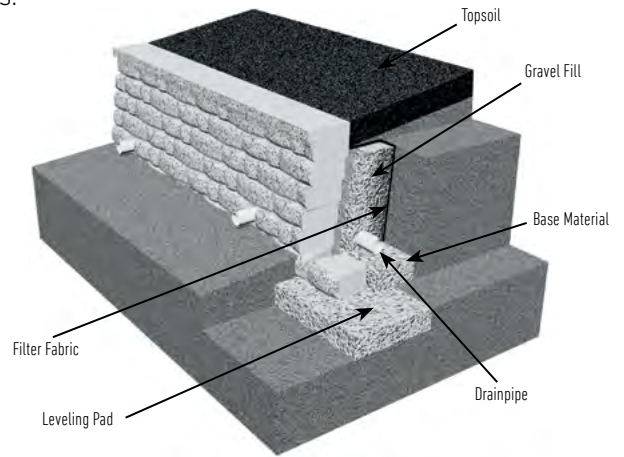

GEOSYNTHETIC-REINFORCED RETAINING WALL

The second category is a geosynthetic-reinforced wall, which needs to be designed by a qualified engineer. There are (theoretically) no height limitations with reinforced retaining walls, and they are used in larger applications. It requires more work area behind the structure.

The block of soil is stabilized by introducing reinforcement layers into the soil mass behind the facing units. The larger the stabilized soil mass, the more soil can be retained or held back. The geogrid in the soil extends past the theoretical failure plane and serves to create a large, coherent gravity mass of block, geogrid, and soil, to resist the forces exerted by the retained soil.

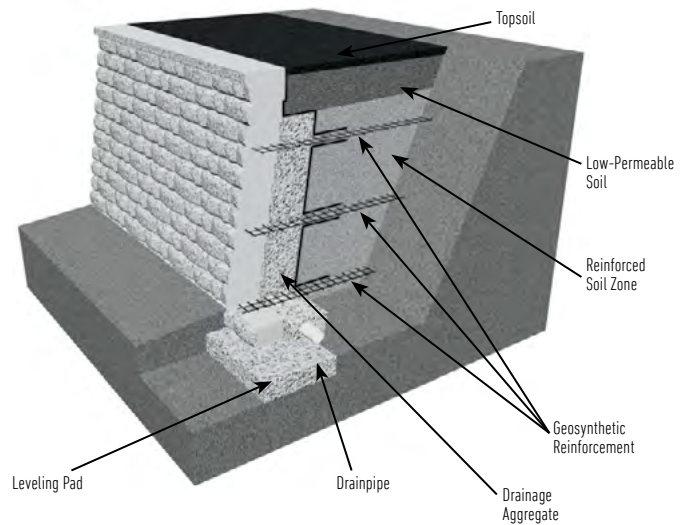

ANCHORPLEX® SYSTEM

The third category is the Anchorplex system, which offers a unique, non-conventional solution to problematic wall construction sites. It is a retaining wall built with Oldcastle™ products and structural backfill specified by ANCHOR Diamond®, and backed by engineering support tools developed by ANCHOR Diamond.

Use of the Anchorplex system eliminates the need for the geogrid and requires substantially less excavation that is usually necessary in geosynthetic-reinforced wall construction.

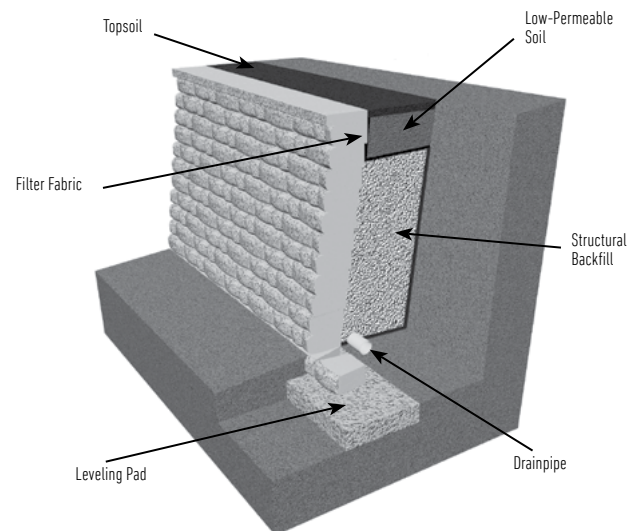

Contact ANCHOR Diamond at 1-877-295-5415 for more information about designing and building with the Anchorplex system.

BEFORE YOU BEGIN

Advance planning and careful layout at the job site help ensure a successful retaining and freestanding wall project.

- Review the site plan to confirm lot lines, wall location, length and elevations.
- Understand on-site soils. Ideal soils are sand and gravel. For walls built in clay or poor soils, work with a local engineer to confirm the wall design and the required soil reinforcement. Black or organic soils should not be used as backfill.
- Confirm the location of underground utilities. Call 811.
- Seek all necessary building permits.
- Prepare a drawing of the site with the wall location, lengths and elevations.
- Plan drainage to avoid erosion or buildup of water behind the wall. Consider where the water will drain through the wall, where downspouts will expel and whether there's an underground sprinkler. For walls greater than three feet in height, a perforated drainpipe is recommended at the base of the aggregate to quickly remove large amounts of water.
- A best practice is to divert water away from the wall before it has an opportunity to enter the reinforced soil and gravel fill zone.
- Check the block delivered to ensure it is the correct product and color. Check the geogrids to confirm that it's the strength and weight specified in the engineering plans.
- Be sure to use the right tools. Hand tools include a shovel, 4-foot level, dead-blow hammer, 2- or 3-pound hammer, chisel, hand tamper, hydraulic splitter and string line. Power tools may include a circular saw with a diamond blade and a plate compactor.
- Always wear protective eye wear.

For additional wall installation references go to Belgard.com.



BASIC INSTALLATION CONSTRUCTION GUIDE - RETAINING WALL

STAKE OUT THE WALL

- Have a surveyor stake out the wall's placement. Verify the locations with the project supervisor.

EXCAVATION

- Excavate for the leveling pad according to the lines and grades shown on the approved plans and excavate enough soil behind the wall for the geogrids material, if needed.
- The trench for the leveling pad should be at least 12 inches wider than the block you are installing and 6 inches below the bottom of the block. *See Diagram 1.*

LEVELING PAD

- An aggregate leveling pad is made of compactable base material of $\frac{3}{4}$ -inch minus (with fines).
- The pad must extend at least 6 inches in front of and behind the first course of block and be at least 6 inches deep after compaction.
- If the planned grade along the wall front will change elevation, the leveling pad may be stepped up in increments of the block height to match the grade change. Start at the lowest level and work upward whenever possible.
- Compact the aggregate and make sure it's level front to back and side to side. *See Diagram 2.*

BASE COURSE

- This is the most important step in the installation process. Bury the base course of block a minimum of 6 inches or as shown on the plans.
- Begin laying block at the lowest elevation of the wall. Remove the rear lip (if applicable) of the block by hitting from the back so that it will lie flat on the leveling pad. *See Diagram 3.*
- Place first block and level, front to back and side to side; lay subsequent blocks in the same manner.
- Place the blocks side by side, flush against each other, and make sure they are in full contact with the leveling pad.
- If the wall is on an incline, don't slope the blocks; step them up so they remain consistently level.
- Use string line along the back edge of block to check for proper alignment.
- For multi-piece products, use the largest unit, 18 inches wide, for the base course.
- Fill cores (if applicable) and voids between blocks with $\frac{3}{4}$ -inch free-draining aggregate prior to laying the next course of block. Clean any debris off the top of the blocks. *See Diagram 4.*
- Install any location devices, such as pins, prior to placing the second course of blocks."
- Install any location devices, such as pins, prior to placing the second course of blocks."

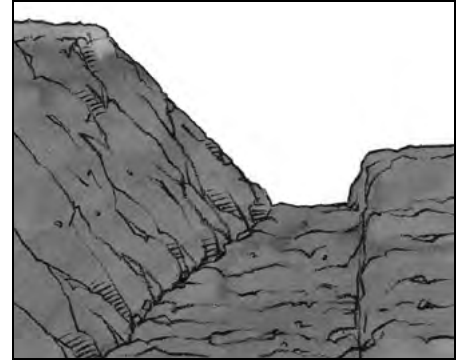

Diagram 1 – Excavation

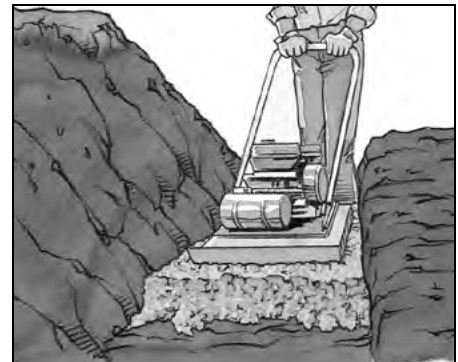

Diagram 2 – Leveling Pad



Diagram 3 – Base Course

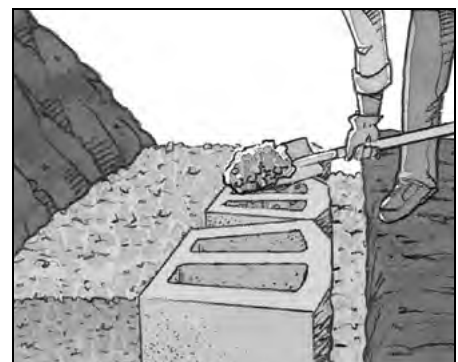

Diagram 4 – Core Fill

CONSTRUCTION OF SUBSEQUENT COURSES

- Clean any debris off the top of the blocks.
- Place the second course of blocks on top of the base course. Maintain running bond. Pull each block forward as far as possible to ensure the correct setback. *See Diagram 5.*
- Fill cores (if applicable) and voids between blocks with $\frac{3}{4}$ -inch free-draining aggregate prior to laying the next course of block. Clean any debris off the top of the blocks.
- Backfill with $\frac{3}{4}$ -inch free-draining aggregate directly behind the block, adding 6 inches at a time followed by proper compaction. Fill thickness will be dependent on compaction equipment
- Add retained soil behind the aggregate. Compact before the next course is laid.
- Don't drive heavy equipment near the wall. Self-propelled compaction equipment should not be used within 3 feet from the back of the wall
- Keep the wall bond by placing units in a staggered relationship to the course beneath.
- You may need partial units to stay on bond. A saw with a diamond blade is recommended for cutting partial units. Use safety glasses and other protective equipment when cutting.

DRAINAGE DESIGN

- Each project is unique. The grades on your site will determine at what level to install the drainpipe.
- Place the drainpipe as low as possible behind the wall so water drains down and away from the wall into a storm drain or to an area lower than the wall. *See Diagram 6.*
- Fill in the area behind the blocks with $\frac{3}{4}$ -inch free-draining aggregate, at a minimum of 12-inches from behind the back of the block or 24-inches from the front of the block, whichever is greater.
- You may need to place and backfill several courses to achieve the proper drainage level. *See Diagrams 7 and 8.*
- The drainpipe outlets should be spaced not more than every 50 feet and at low points of the wall. In order for the gravel fill to function properly, it must keep clear of regular soil fill. See below diagram of daylight drainage system.

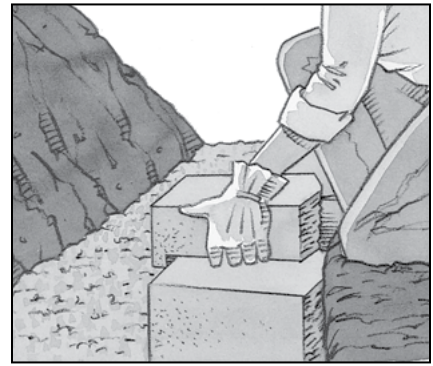

Diagram 5 – Next Course Construction

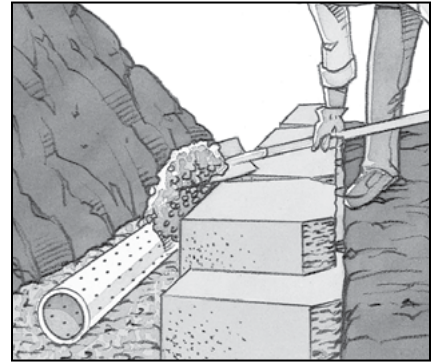

Diagram 6 – Drainage

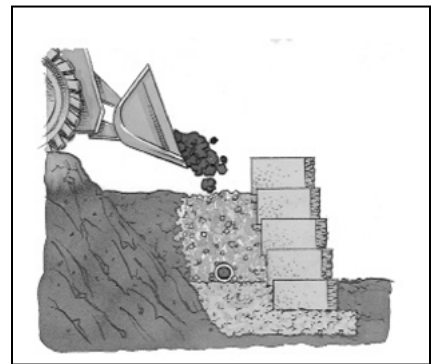

Diagram 7 – Backfill

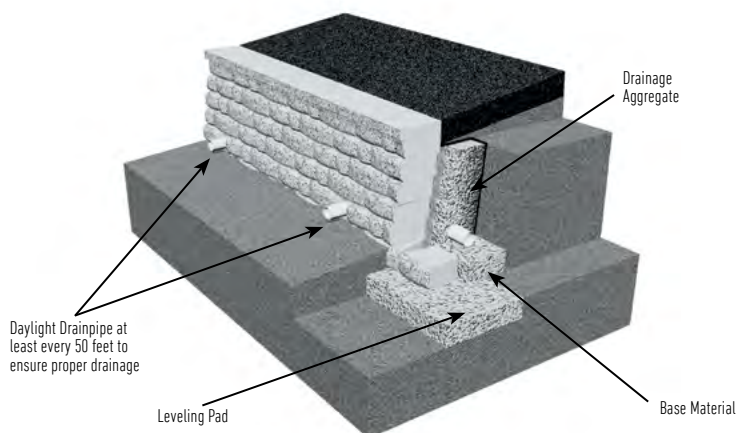
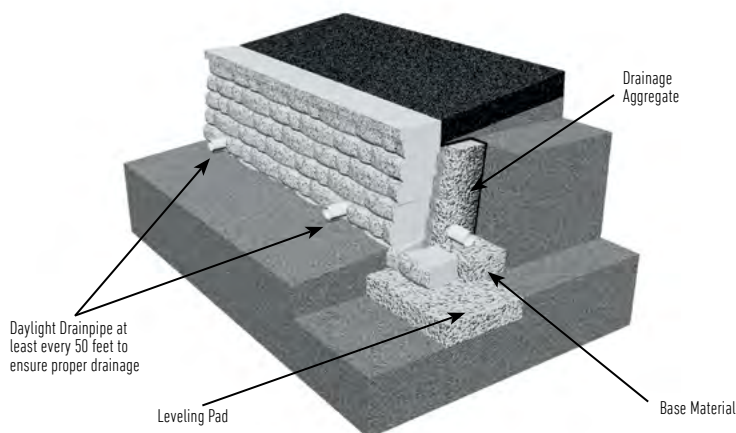

Diagram 8 – Compaction



STEPPING UP THE BASE AT LOWEST POINT

Walls built on a sloping grade require a stepped base. Begin excavation at the lowest point and dig a level trench into the slope until it is deep enough to accommodate the base material and the height of two entire blocks. A minimum embedment of 6 inches is required at all times.

STEP-UP

At this point, step up the height of one block and begin a new section of base trench. Continue to step up as needed to top of slope. Always bury at least one full unit at each step, maintaining a minimum embedment of 6 inches at all times.

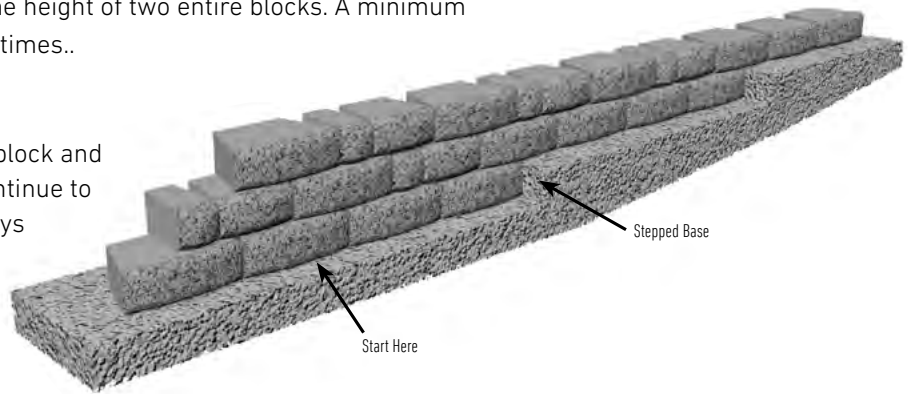

STEPPING UP THE BASE USING THE U START BASE BLOCK

Walls built on a sloping grade require a stepped base. Begin excavation at the lowest point and dig a level trench, 24 inches wide, into the slope until it is deep enough to accommodate the base material, the base block and enough depth to maintain a minimum of 6 inches of embedment after stepping up.

See Diagram 9.



Diagram 9 – Drainage

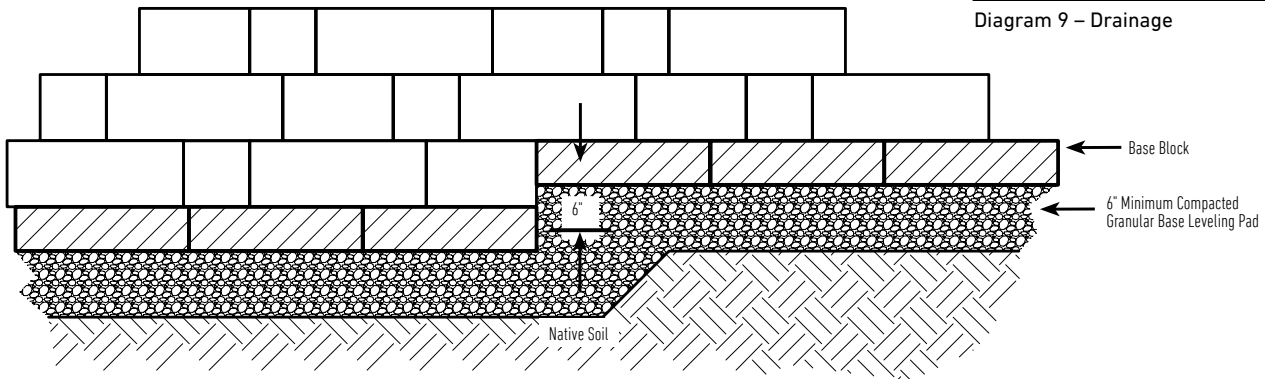

XL™ CAP

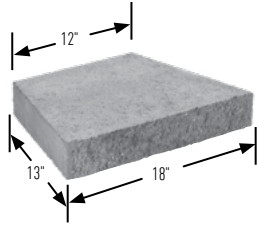

STRAIGHT WALL

The XL™ cap must be laid alternately, short and long faces for a straight line. Always start capping from the lowest elevation. Once caps are aligned, caps should be glued in place using a concrete adhesive.

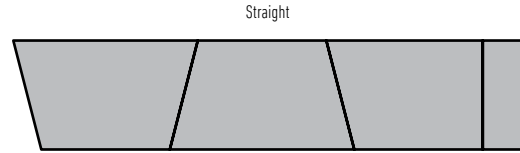

CURVES

Lay out the cap units side by side with the same face facing out (long faces for outside curves; short face to inside curves). If there's a need to adjust for project's radius, make cuts at least every other cap as needed for the most pleasing aesthetic.

- Minimum radius with XL™ cap: 2 feet 2 inches

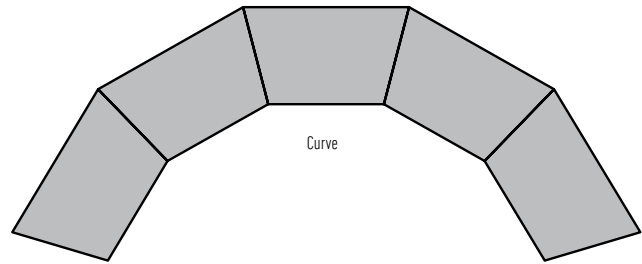

90-DEGREE CORNERS

Saw-cut two caps to achieve a 45-degree mitered corner.

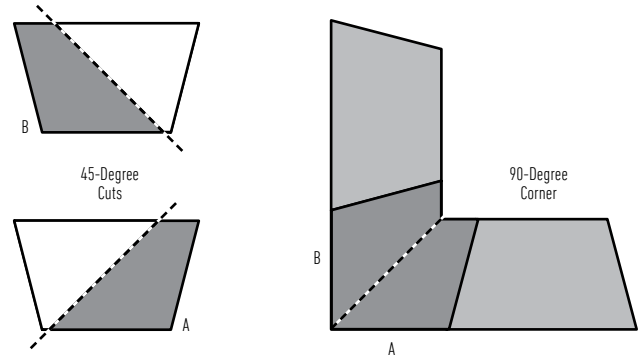

STEPPING UP CAPS WITH XL™ CAP

If the wall elevation changes, caps can be stacked where the wall steps up. Begin laying caps at the lowest elevation change and work your way toward the next step up. Split* a cap unit to fit. Place the split unit directly on top of the capped portion of the wall with all three split faces exposed.

FINISHING WITH XL™ CAP

After layout is complete and caps are saw-cut or split to size, carefully place concrete adhesive on wall top course and then place caps.

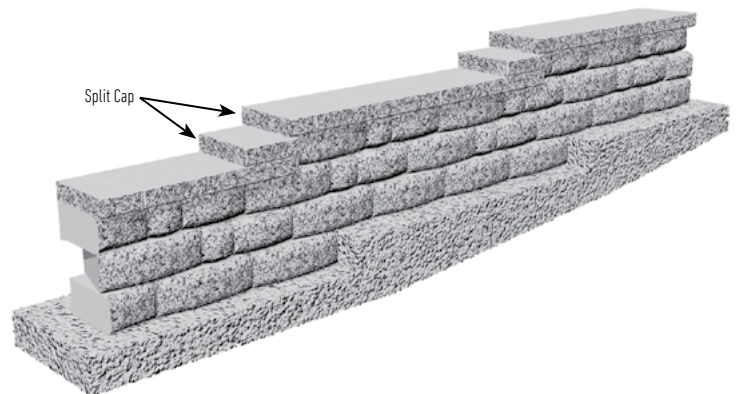

***NOTE:** To split a block, use a hydraulic splitter or split manually by using a hammer and chisel to score the block on all sides. Pound the chisel on the same line until the block splits. If partial unit sides are not exposed, use a saw with a diamond blade to achieve a tighter fit.

GEOSYNTHETIC REINFORCEMENT (IF REQUIRED)

- Geosynthetic reinforcement is recommended for walls taller than the gravity height determined for the project, or walls situated in poor soils, supporting a driveway, etc. Consult an engineer for design assistance.
- Check the wall construction plan for which courses will need geogrids.
- Clean any debris off the top layer of blocks.
- Measure and cut the geogrids to the design length in the plans.
- Many geosynthetic reinforcements have a design strength direction, which must be laid perpendicular to the wall.
- Place the front edge of the geogrids on top of the block, making sure it's within 1 inch of the face of the block. Correct placement ensures that you maximize the connection strength and keep the batter consistent.
- Apply the next course of blocks to secure it in place.
- A minimum of 6 inches of backfill is required prior to operating vehicles on the geogrids. Avoid sudden turning or braking.

COMPACTION

- Place the backfill soil behind the drainage aggregate and compact to 95% standard PROCTOR density with a hand-operated compactor.
- Make sure the aggregate is level with or slightly below the top of the course.
- Place soil in front of the base course and compact. The base course should be buried.
- Continue to fill and compact.

FINISH GRADE AND SURFACE DRAINAGE

- Protect the wall with a finished grade at the top and bottom.
- To ensure proper water drainage away from the wall, use 8 inches of soil with low permeability. This will minimize water seeping into the soil and gravel fill behind the wall. *See Drainage Swales.*

SITE CLEANING AND RESTORATION

- Brush off the wall and pick up any debris left from the construction process.
- Notify the job superintendent in writing of the project's completion and that it is ready for final inspection and acceptance.
- Planting vegetation in front and on top of the wall will help reduce the chance of erosion.
- Following the best practices for construction will ensure the successful installation of Anchor™ products.

DRAINAGE SWALES

- Design and performance of most retaining walls are based on keeping the reinforced zone relatively dry. Appropriate drainage swales to help control water should be designed into the wall construction plan.

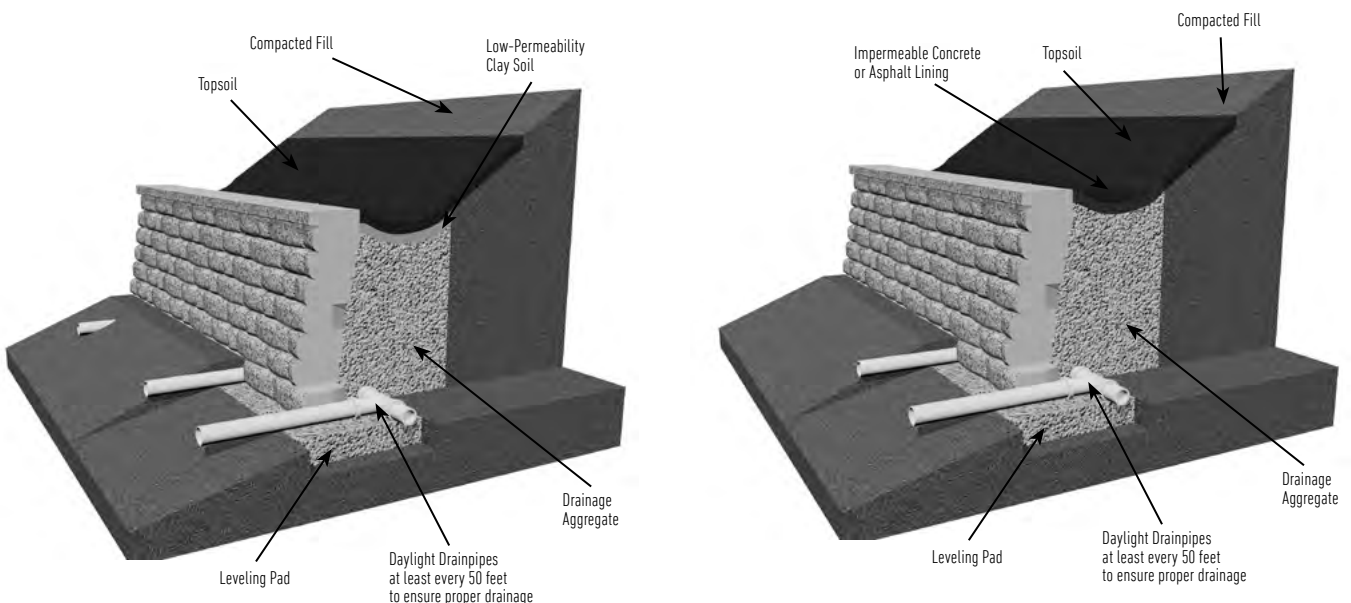

SAFETY NOTE: Always use appropriate equipment, including safety glasses or goggles and respirators, when splitting, cutting or hammering units. Refer to the NCMA Segmental Retaining Wall Installation Guide at www.ncma.org.

ABUTTING AN EXISTING STRUCTURE

FIRST COURSE

Begin with the first block next to the wall and place the first course. Place filter fabric behind the first two units and extend it 2 feet along the existing structure.

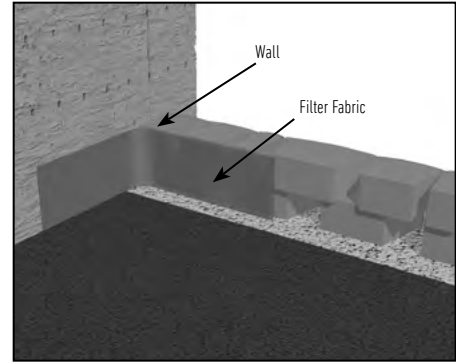
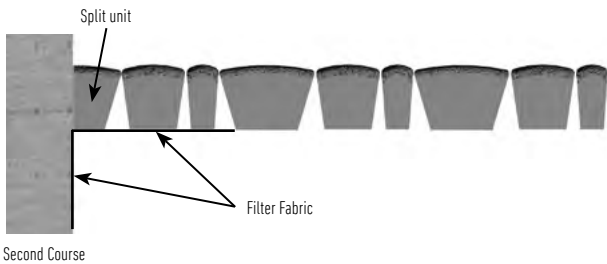

Diagram 10 – Extend Filter Fabric

SECOND COURSE

Build second course with standard installation techniques. A split unit is shown but may not be necessary in every installation. Extend filter fabric to the top edge of the final course. *See Diagram 10.* A rubber membrane may be placed between the units and a non-concrete wall to prevent moisture damage to the structure.



Note: To split a block, use a hydraulic splitter or split manually by using a hammer and chisel to score the block on all sides. Pound the chisel on the same line until the block splits. If partial unit sides are not exposed, use a saw with a diamond blade to achieve a tighter fit.

OUTSIDE CURVES

CALCULATE THE RADIUS

When building an outside curve, begin by determining the desired radius of the top course. This will be the smallest radius in the wall and must not be less than the minimum radius for the wall system used.

To determine the approximate base course radius:

- 1) Add ¼-inch to the setback of the block used. Multiply that by the number of courses in the finished wall.
- 2) Add desired radius length of the top course to the result of step 1. This number equals the approximate radius length of the base course.
- 3) To determine the radius for the front edge of the trench, add 6 inches to the approximate radius length of the base course.

Example: Setback of the Highland Stone® product is 1⅛-inch. The wall is 8 courses high. The desired radius of the wall measured to the front of the block on the top course is 6 feet.

- 1) Setback multiplied by number of courses
 $1\frac{1}{8}'' + \frac{1}{4}'' = 1\frac{3}{8}'' \times 8 \text{ courses} = 11''$
- 2) Desired radius plus setback
 $6' + 11'' = 6'11''$
- 3) Front of trench
 $6'11'' + 6'' = 7'5''$

TIP: Subtract the depth of the block if you prefer to mark the curve from the back of the block.

LAY OUT THE TRENCH

Drive a stake into the ground at the desired radius point of the curve. Attach a string and rotate it in an arc at the desired length to mark the curve in the soil. Dig the trench.

BASE COURSE

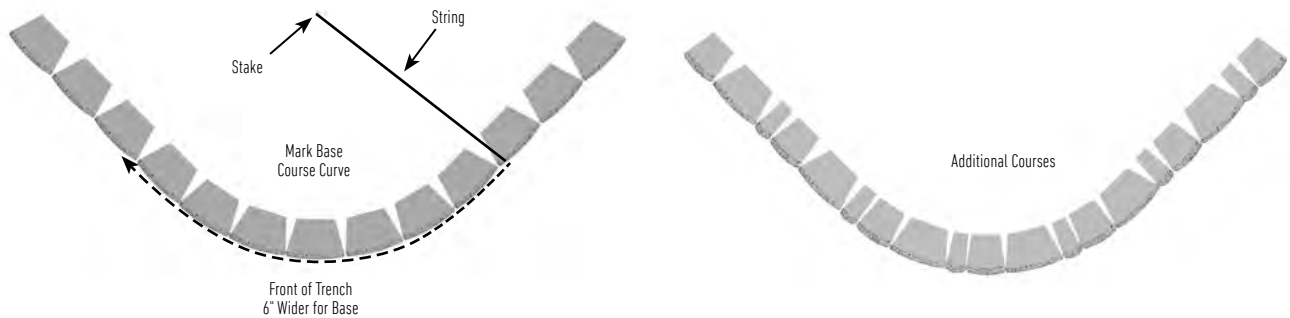

Using the existing radius point stake and string, mark the base course curve on the leveling pad. Align the front of the block with the marked curve and ensure level placement from side to side and front to back.

ADDITIONAL COURSES

On each course, some of the rear lip of each block must be in contact with the back of the units below to ensure structural stability. The setback of the block will cause the radius of each course to gradually decrease and eventually affect the running bond of the wall. To maintain proper running bond, use partial units as needed. Once a split or cut unit is cut to size, glue in place with a concrete adhesive.

INSIDE CURVES

CALCULATE THE RADIUS

Check the wall plan to determine the radius of the top course. This will be the biggest radius in the wall and you will need it to determine the radius at the base course, which will be the smallest radius of the wall and must not be less than the minimum for the block system used.

A QUICK WAY TO DETERMINE THE BASE COURSE RADIUS:

- 1) Add ¼-inch to the setback of the block used. Multiply that by the number of courses in the finished wall.
- 2) Subtract the result of step 1 from the radius of the top course. This number equals the approximate radius length of the base course.
- 3) To determine the radius for the front edge of the trench, subtract 6 inches from the approximate radius length of the base course.

Example: The setback of the Highland Stone® product is 1⅛-inches. The wall is 8 courses high. The desired radius of the wall measured to the front of the block on the top course is 10 feet.

- 1) Setback multiplied by number of courses
 $1\frac{1}{8}'' + \frac{1}{4}'' = 1\frac{3}{8}'' \times 8 \text{ courses} = 11''$
- 2) Desired radius minus setback
 $10' - 11'' = 9'1''$
- 3) Front of trench
 $9'1'' - 6'' = 8'7''$

TIP: Add the depth of the block if you prefer to mark the curve from the back of the block.

LAY OUT THE TRENCH

Drive a stake into the ground at the desired radius point of the curve. Attach a string and rotate it in an arc at the desired length to mark the curve in the soil. Dig the trench.

BASE COURSE

Using existing radius point stake and string, mark the base course curve on the leveling pad. Align the front of the block with the marked curve and ensure level placement from side to side and front to back.

ADDITIONAL COURSES

On each course, some of the lips of each block must be in contact with the back of the units below to ensure structural stability. If not, use construction adhesive to adhere blocks together. To maintain proper running bond, use partial units as needed. Once a split unit is cut to size, glue in place with a concrete adhesive.

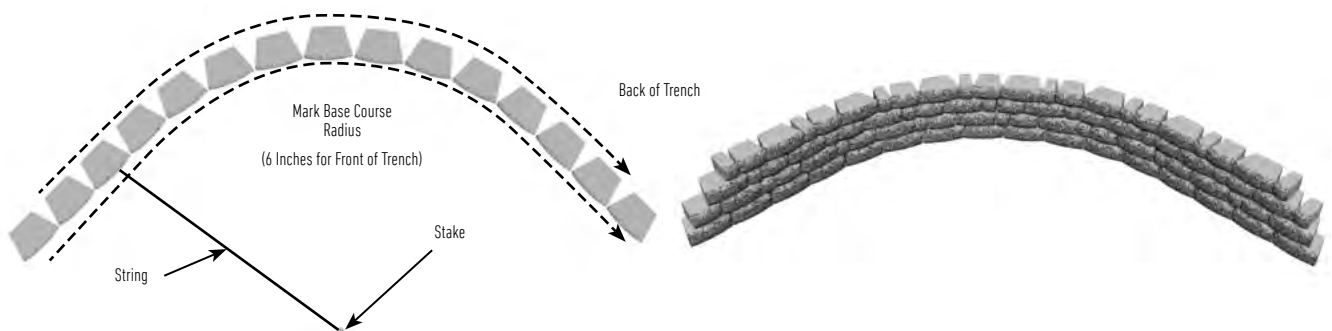

OUTSIDE 90-DEGREE CORNERS

FOR SYSTEMS WITHOUT A CORNER UNIT

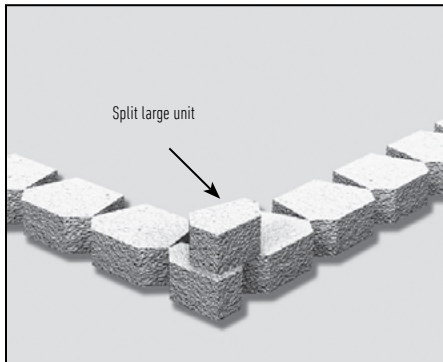

Outside 90-Degree Corner without Corner Unit

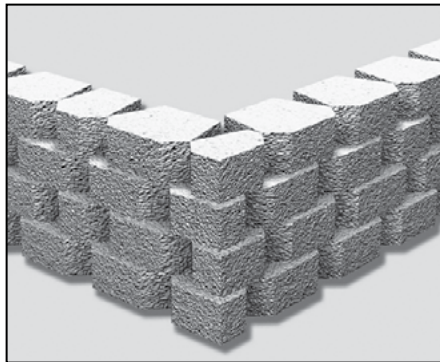

Additional Courses

BASE COURSE

To build an outside 90-degree corner, begin by splitting a unit in half. Place this unit with both split faces out at the corner. If needed, remove the rear lip so that the block lies flat. Then lay the rest of the base course working from the corner block out.

ADDITIONAL COURSES

Begin the next course with the other half of the split unit faced in the opposite direction at the corner. Place the second and third blocks on either side of the corner unit. Once the corner unit is in position, glue block in place with a concrete adhesive. Continue to alternate the corner unit orientation with each course and always use a concrete adhesive on the corner units. Use cut or split units as necessary to maintain running bond.

OUTSIDE 90-DEGREE CORNERS

FOR SYSTEMS WITHOUT A CORNER UNIT

90-degree corners are built by alternating corner/column units so the long side is on different sides of the wall. Build the pattern from the corner unit when possible. Install corner units level from front to back.

Depending on the wall layout, there may be a need to go off the pattern and randomly place wall blocks near the corner. Set back corner units to reflect the batter of the wall block units and glue from bottom to top.



Outside 90-Degree Corner with Corner/Column Unit

NOTE: To split a block, use a hydraulic splitter or split manually by using a hammer and chisel to score the block on all sides. Pound the chisel on the same line until the block splits. If partial unit sides are not exposed, use a saw with a diamond blade to achieve a tighter fit.

INSIDE 90-DEGREE CORNERS

BASE COURSE

To create an inside 90-degree corner, begin by placing a block at the corner. Then lay a second block perpendicular to the first and continue laying out the rest of the base course working from the corner out. Make sure to construct the base course according to standard site prep and installation procedures.



Example Inside 90-Degree Corner

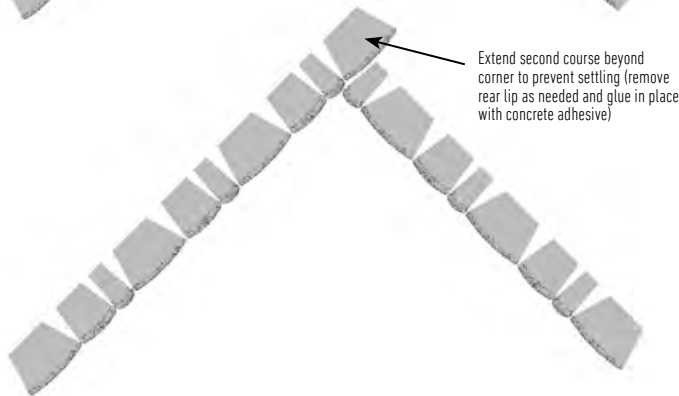
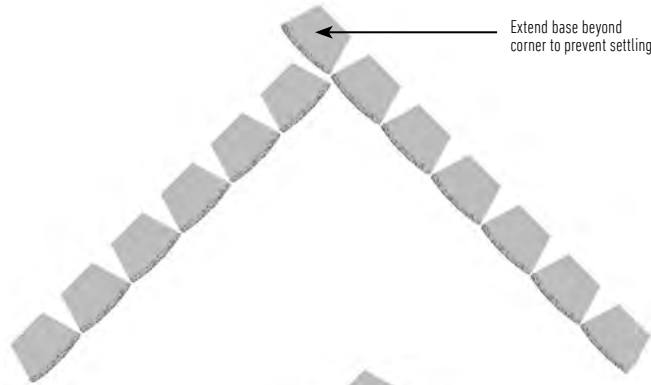

ADDITIONAL COURSES

On the second course, place all blocks on bond along one side of the corner. Once the second course of one wall is established, begin the second course of the adjacent wall. Split units or units of varying sizes may be required on this wall to maintain running bond. Continue to alternate the corner unit orientation with each course and always use a concrete adhesive on the corner units.

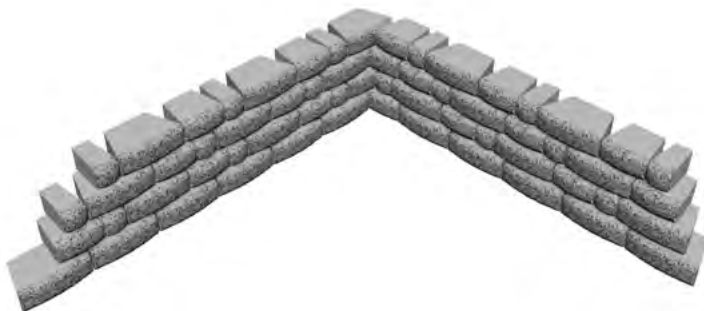

NOTE: To split a block, use a hydraulic splitter or split manually by using a hammer and chisel to score the block on all sides. Pound the chisel on the same line until the block splits. If partial unit sides are not exposed, use a saw with a diamond blade to achieve a tighter fit.

STEPS IN A CURVED WALL

These drawings show Highland Stone®, Diamond® and Diamond Stone Cut® step units. Caps or pavers can be used for treads. Check local building codes for any tread depth standards.



BASE COURSE

Thoroughly compact the leveling pad. Lay out the base course according to the wall design. Place step units first, working from the center to each side. Remember, it is very important to backfill and compact behind and along the sides of each course of step units.



FIRST STEP COURSE

Place the first course of step units directly on top of the base course so there is no setback. Stagger them from the previous course and glue in place.



SECOND STEP COURSE

Add the second course of steps, staggering them from the previous course to maintain running bond. Overlap the lower course by a minimum 2 inches and glue to lower course. Place and compact base material prior to installing next course.



NEXT WALL COURSE

Place a block near the second course of steps, maintaining running bond with the base course. Measure and cut a block to fit the space remaining between the step unit and the next course of the wall. Place the unit in the wall, making sure that both vertical edges fit tight against both the step and standard unit. Remove the rear lip on the blocks when necessary, and angle the blocks flush with the face of the previous course. Glue in place with a concrete adhesive. Repeat these steps until the wall is finished.

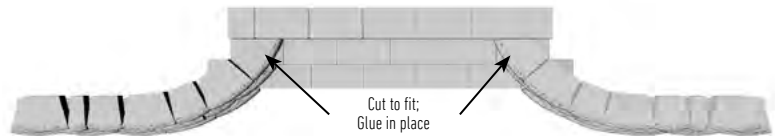

ADDITIONAL COURSES

Beginning in the center, add the third course of steps, lining up the units with the first course. Overlap a minimum 2 inches and glue in place. Repeat until the steps are finished.

DRAINAGE TIP: Drain pipe can be placed behind the lowest step units at grade or behind each wall adjacent to the steps.

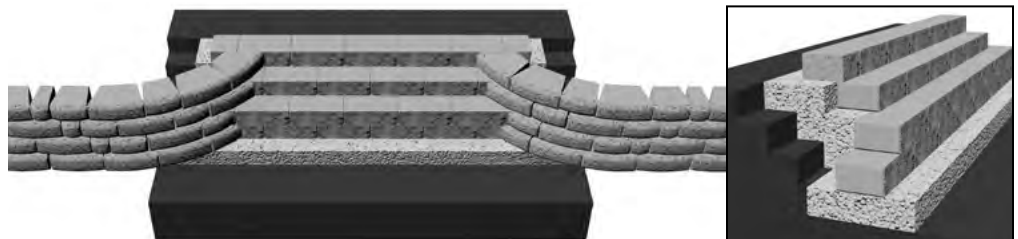

STEPS IN A 90-DEGREE WALL

These drawings show Highland Stone®, Diamond® and Diamond Stone Cut® step units. Caps or pavers can be used for treads. Check local building codes for any tread depth standards.



BASE COURSE

Thoroughly compact the leveling pad. Lay out the base course according to the wall design. Place step units first, working from the center to each side. Remember, it is very important to backfill and compact behind and along the sides of each course of step units.

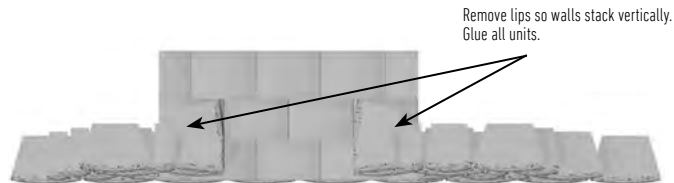

FIRST STEP COURSE

Place the first course of step units directly on top of the base course so there is no setback. Stagger them from the previous course and glue in place.



SECOND STEP COURSE

Add the second course of steps, staggering them from the previous course to maintain running bond. Overlap the lower course by a minimum 2 inches and glue to lower course. Place and compact base material prior to installing next course.

SECOND WALL COURSE

Build the second course of the wall. Corner units are used at the end of steps tied into wall and glued in place. Alternate long and short direction of corner unit every other row.

THIRD STEP COURSE

Beginning in the center, add the third course of steps, lining up the units with the first course. Overlap the lower course by 2 inches and glue to lower course.

ADDITIONAL COURSES

Build the third course of the wall. Repeat these steps until the wall is finished.

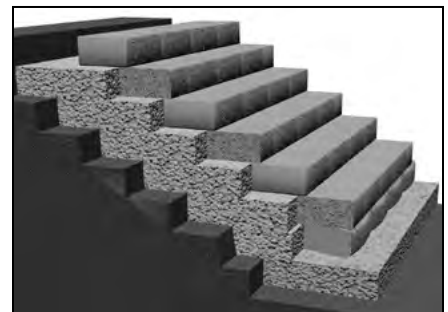
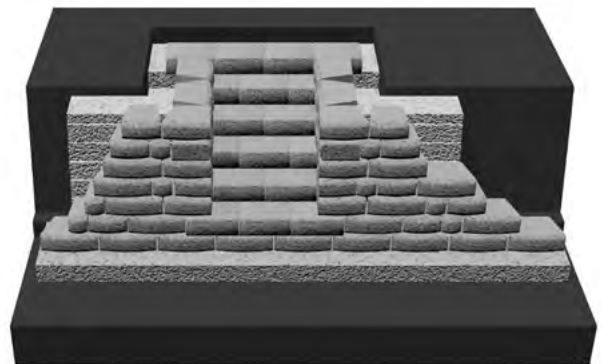

ANCHORPLEX® SYSTEM CONSTRUCTION GUIDE

HOW TO USE THIS GUIDE

Use this information to gain a general understanding of the basics of building retaining walls with the Anchorplex system. Do not use this in lieu of construction drawings provided by a qualified engineer. Contact ANCHOR Diamond® at 1-877-295-5415 for more information about designing and building with the Anchorplex system.

ABOUT THE ANCHORPLEX® SYSTEM

The Anchorplex system is a retaining wall built with Oldcastle™ products and self-compacting structural backfill, also known as “no-fines” concrete, which is a highly-porous mixture of clean stone, cement and water. The mixing ratios (by weight) of aggregate to cementitious material should be between 6:1 and 7:1. The mixing rate (by weight) of water to cementitious material should be no more than 1:2. The resulting material, upon curing, should have at least 25 percent voids.

RETAINING WALL CONSTRUCTION

Setting out the wall and excavation is no different for an Anchorplex system construction than for conventional construction, except that the amount of excavation will probably differ. Construction of the leveling pad, base course, subsequent courses and drainage is no different for an Anchorplex system construction than for conventional construction.

INSTALLATION OF STRUCTURAL BACKFILL

After completion of the leveling pad, base course, drainpipe installation and stacking block 2 feet above grade, the first lift of structural backfill that meets Anchor Wall Systems' specifications can be installed. Do not exceed 2 feet vertical stacking of block before placing a lift of structural backfill

The structural backfill can be placed directly from delivery vehicle or with skid-type loader or other equipment. It should be placed behind the blocks and worked into all voids and cores of the blocks (if applicable). When properly formulated, the structural backfill will not leak through the face of the wall.

After installation of the first lift of structural backfill, install additional courses and repeat the process. Place additional lifts every 8 to 24 inches depending on site conditions and project scale. Subsequent pours can be made as soon as the structural backfill in the previous lift has set — usually within 2 to 3 hours.

INSTALLATION OF FILTER FABRIC

Place a layer of filter fabric over the structural backfill and up the back of the top course and the cap. Then fill behind the top course and cap with low-permeability soil.

CAPPING & FINISHING

Follow standard practice when capping the wall. Protect the wall with a finish grade at the top and bottom.

EXAMPLE: 6" MULTI-PIECE RETAINING WALL SYSTEM USING THE ANCHORPLEX SYSTEM

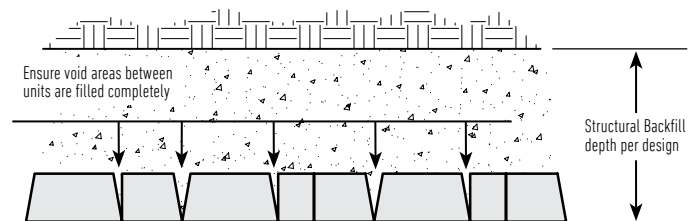
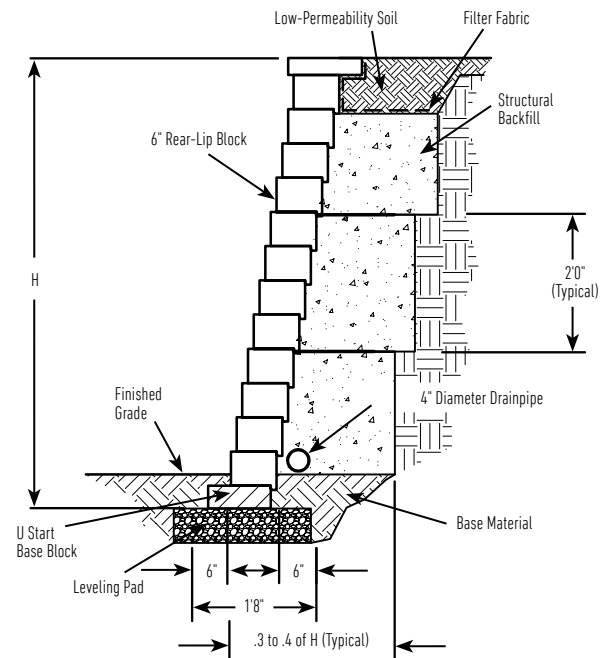

LAYING PATTERN GUIDE FOR MULTI-PIECE WALLS

USING A PATTERN FOR SINGLE-HEIGHT RETAINING WALLS

When using a pattern, begin at one edge, laying the units as indicated. Install at least one repeat of the pattern before proceeding to the next course. Stagger the patterns as shown to avoid vertical bonds.

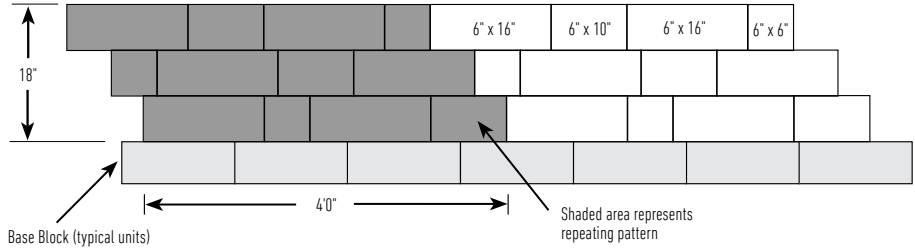

One set of 6-inch-high retaining wall blocks consists of 2 large units, 1 medium unit and 1 small unit, and is 2 square feet.

6" Multipiece wall system, 18-inch by 4-foot pattern = 6 sq. ft.

Blocks required		Blocks required	
12	6" x 16"	6	6" x 16"
6	6" x 10"	3	6" x 10"
6	6" x 6"	3	6" x 6"

USING A PATTERN FOR FREESTANDING WALLS

One set of 6-inch-high blocks consists of 2 large units, 1 medium unit and 1 small unit, and is 1 square foot of two sided wall.

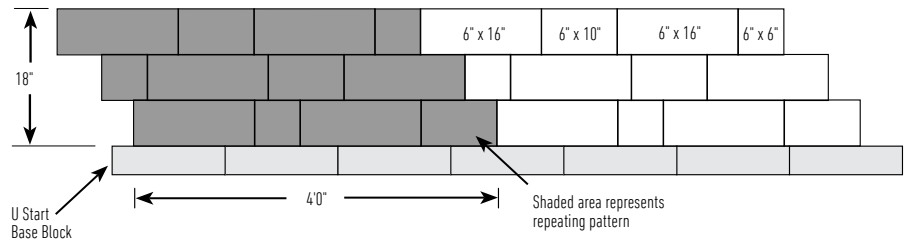

Note: These freestanding wall installation patterns show only one side of the freestanding wall. The same number of blocks are needed to build the other side of a freestanding wall when using Belair Wall 2.0 and Brisa freestanding wall systems. Freestanding wall installation patterns are measured in length by height of one side of the wall, and are expressed in square feet. Sets of blocks required include the number of blocks needed to build both sides of the wall.

ENDING A WALL WITH WALL ENDS

Start pattern next to a wall end unit if the wall does not end with a column. Every other wall end is cut in half. Glue all pieces in place using concrete adhesive.

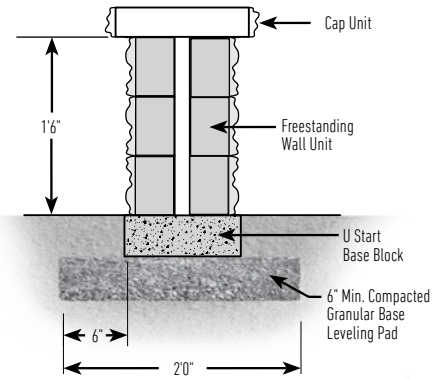

TYPICAL CROSS SECTION

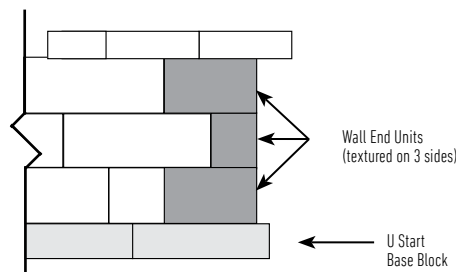

COLUMN CONSTRUCTION

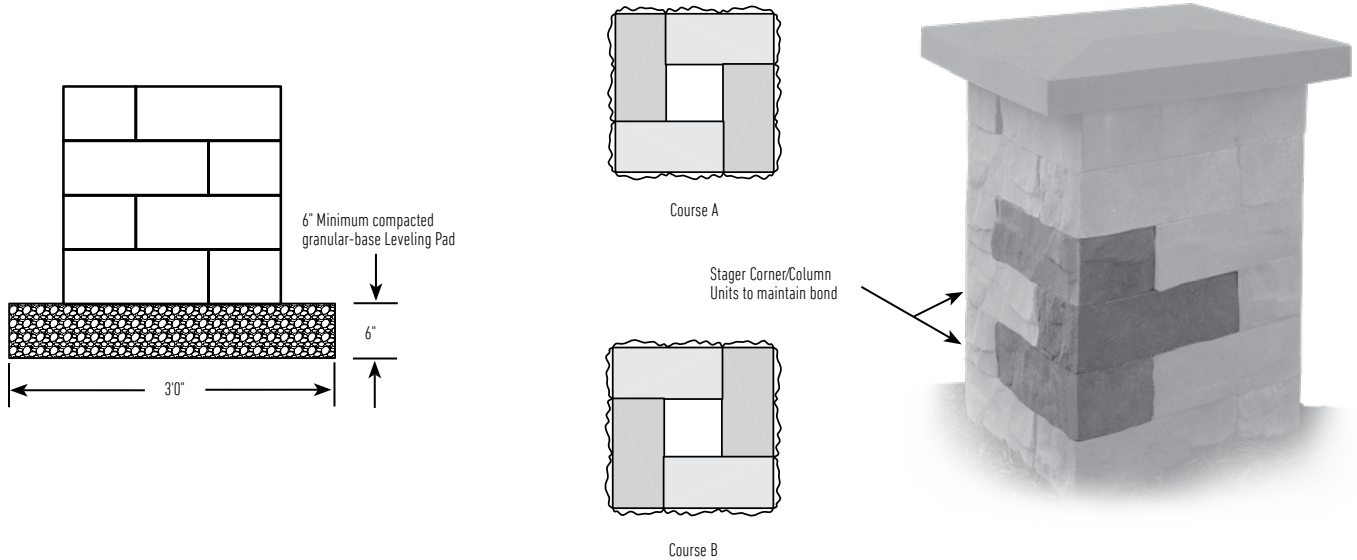

STEPPING UP THE BASE AT LOWEST POINT

Walls built on a sloping grade require a stepped base. Begin excavation at the lowest point and dig a level trench into the slope until it is deep enough to accommodate the base material and height of one entire block.

STEP-UP

At this point, step up the height of one block and begin a new section of base trench. Continue to step up as needed to top of slope. Always bury at least one full unit at each step.

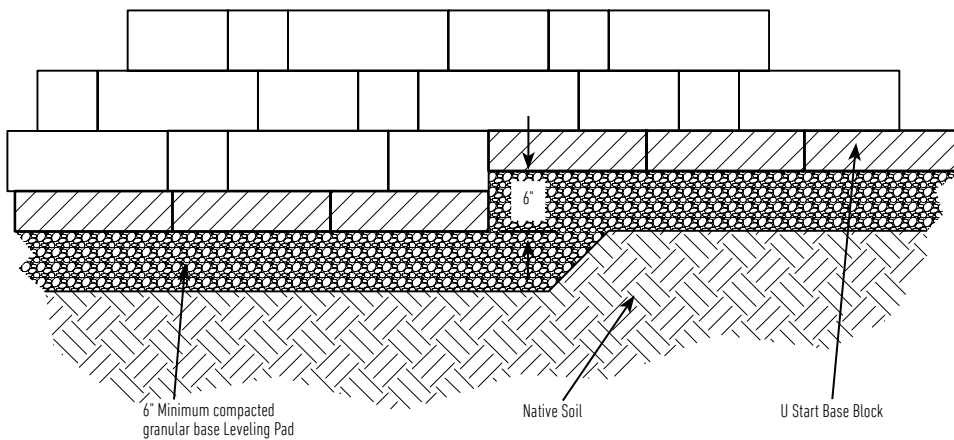

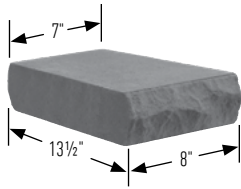

TRAPEZOID DOUBLE-SIDED CAP

The double-sided cap has a right-angle side and an offset-angle side. The caps can be used in any of four directions since there is no specific top or bottom.

STRAIGHT WALL

The cap must be laid alternately, narrow (N) and wide (W) faces, for a straight line. Always start capping from the lowest elevation.

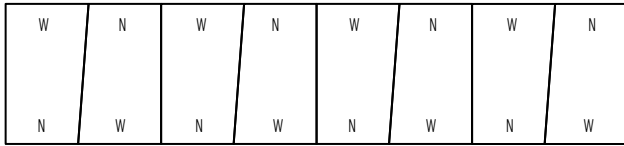

CURVES

Lay out the cap units side by side with same face facing out (wide faces for outside curves; narrow faces for inside curves). Occasional cutting of some pieces may be necessary.

Minimum radius: 7'6"

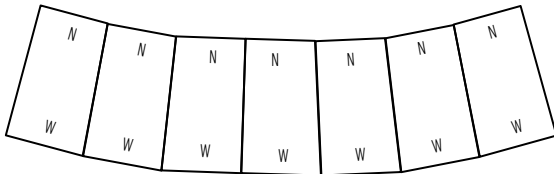

STEPPING UP CAPS WITH CAP ENDS

If a wall elevation changes, caps can be stacked where the wall steps up. Begin laying caps at the lowest elevation and work your way toward the next step-up. Cut a cap unit to fit. Place the cut unit directly on top of the capped portion of the wall with the cut side hidden from view. If not using a Cap End, place the trapezoid double-sided cap so that the side with the arrow is hidden.

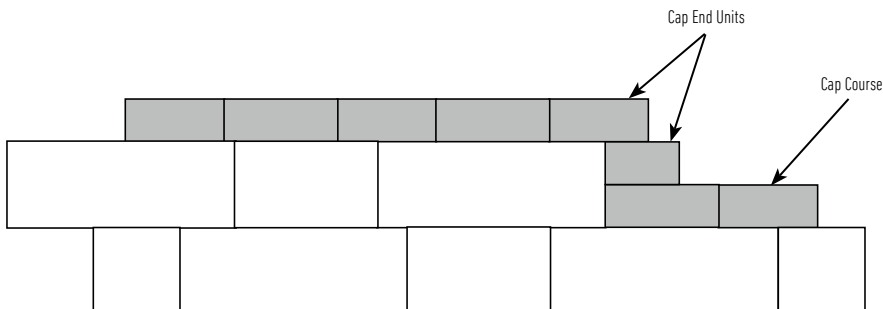

NOTE: To split a block, use a hydraulic splitter or split manually by using a hammer and chisel to score the block on all sides. Pound the chisel on the same line until the block splits. If partial unit sides are not exposed, use a saw with a diamond blade to achieve a tighter fit.

90-DEGREE CORNERS WITH CAP END

Using a Cap End unit.

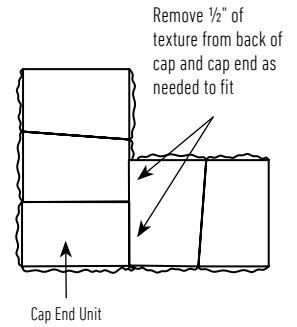
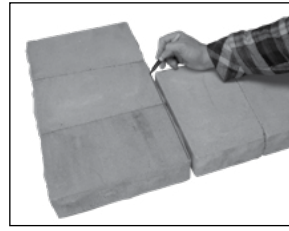

FINISH WITH A CAP END

Do not cut the cap end, cut an interior cap if needed.

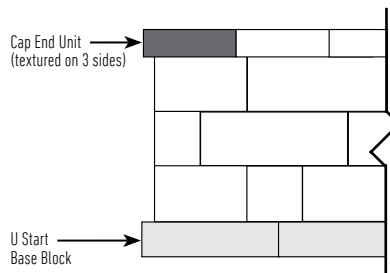

STEP CONSTRUCTION

When constructing steps, you must consider whether it is a fill or a cut-grade situation. Construction is similar, but varies in the amount of dummy units required.

A fill step will have a base course of dummy units in the entire footprint of the steps. For each additional step, add dummy units behind the facing units for stability. There are two methods for creating the step facing. Use sets of either 6-inch-high or 3-inch-high units. A cut-grade set of steps will use one layer of dummy blocks under each step, effectively stepping up the grade.

All applications will require some sort of tread to cover the facing units.

USING FILL SCENARIO

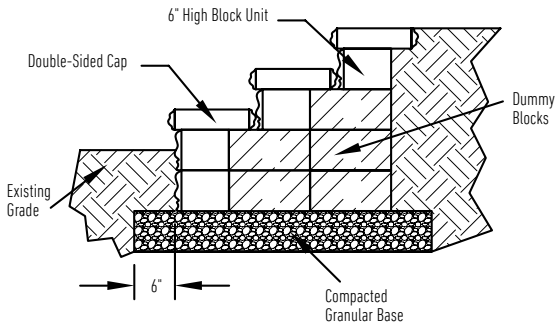

USING CUT SCENARIO

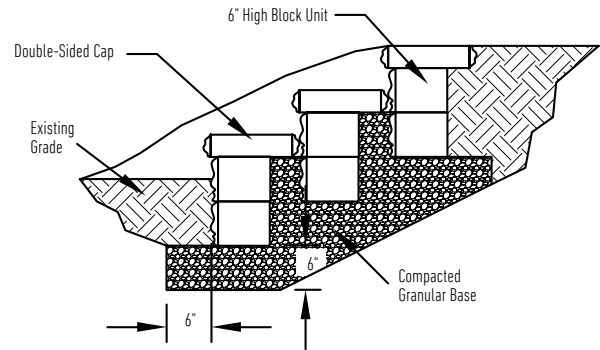

RETAINING WALL SQUARE FIRE PIT CONSTRUCTION

Inside of fire pit must be lined with a heat-resistant material.

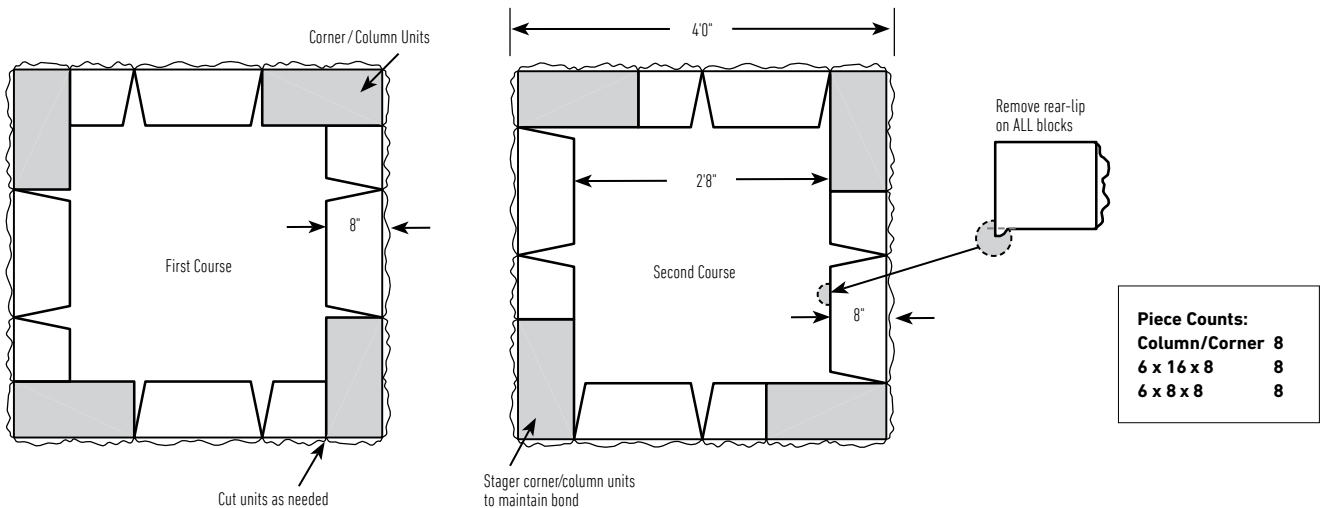
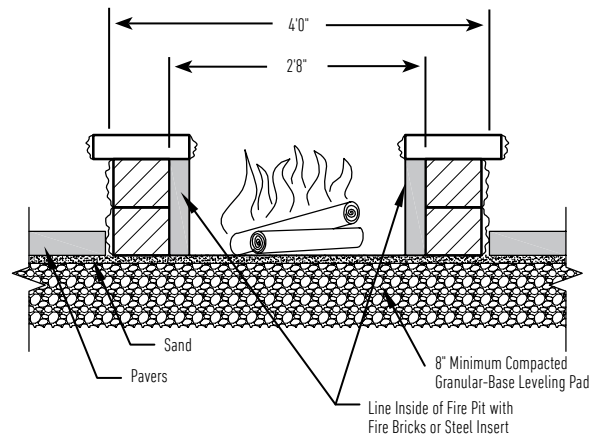

Affix all units with construction-grade adhesive.

These blocks are not fireproof and could start to crack under extreme heat. These blocks are intended for landscape applications and are not fire-rated. Over time the blocks may crack. A possible solution is to use heavy fire-rated bricks or a steel liner on the interior of an above or below ground fire ring/pit with the blocks outside the perimeter. Again, the heat may adversely affect landscape products, even with an interior heat-resistant barrier in place.





Scan for additional
product information

RESIDENTIAL	COMMERCIAL	STEPS	COLUMNS	FIRE PITS	KITCHEN	FREESTANDING WALL	RETAINING WALL
							
✓	✓	✓	✓	✓	✓	✓	✓

SHAPES & SIZES

3-Piece



7 x 13²/₃ x 3



7 x 15²/₃ x 3



7 x 18¹/₂ x 3

Column Unit



7 x 18¹/₂ x 3

Cap



15 x 24 x 3¹/₄

Modular Block



7¹/₁₆ x 7⁷/₈ x 7⁷/₈

UNIT	SQFT/ PALLET	SQFT/ LAYER	LAYER/ PALLET	UNITS/ PALLET	UNITS/ LAYER	UNITS/ SQFT	WEIGHT/ PALLET
------	-----------------	----------------	------------------	------------------	-----------------	----------------	-------------------

3-PIECE

7 X 13 ² / ₃ X 3	19.2	–	–	30	5	1.56	–
7 X 15 ² / ₃ X 3	23.1	–	–	30	5	1.3	–
7 X 18 ¹ / ₂ X 3	27	–	–	30	5	1.1	–
TOTAL	70	11.7	6	90	15	–	2082

COLUMN UNIT

7 X 18 ¹ / ₂ X 3	45	9	5	45	9	2 columns/ pallet	2306
--	----	---	---	----	---	----------------------	------

CAP

15 X 24 X 3 ¹ / ₄	–	–	5	32	16	–	2990
---	---	---	---	----	----	---	------

MODULAR BLOCK

4 X 20 X 10	48.64	12.16	4	128	32	2.6	2816
-------------	-------	-------	---	-----	----	-----	------

TANDEM WALL SYSTEM INSTALLATION INSTRUCTIONS



Remove all surface vegetation and debris. Select the length of the wall and excavate a trench the length of the wall and approximately 12" from top of final grade. Then place a minimum of 6" of dense graded aggregate and compact to 95% standard density or modified. It's not recommended to use a pea rock or a rounded type of material on the base.



Place the Base Block (shown here) on the compacted gravel. Level the base block units front to back as well as side to side. Making sure the units are fully level.



Assemble the Tandem Wall units by inserting the Tandem Wall connectors into the dove tails. Make sure the front and rear panels are the same length.

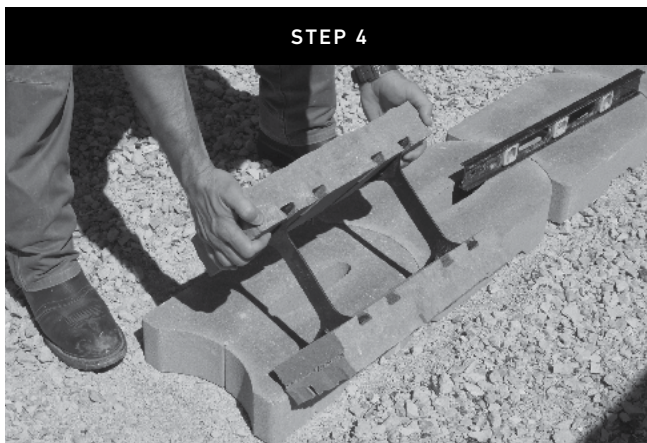

Place the assembled Tandem Wall unit on the top of the U Start Base Block or Torpedo Base Block, making sure that the first course is centered on the base block. Check to make sure units are kept level.



Once the Tandem Wall units have been placed. Run a string line along the back of the front or rear panel to assure you are keeping the wall units straight in line.

STEP 6



Place 3/4" crushed rock in between the panels to provide frictional connection and proper internal drainage.

STEP 7



Lightly hand compact the gravel in between the panels for proper compaction.

STEP 8



Place 12" of 3/4" drainage rock behind the rear panel of the wall. This will provide for proper drainage behind retaining walls.

STEP 9



Set additional courses of the Tandem Wall. Making sure that you are keeping the wall in proper alignment. Backfill and compact each additional course.

STEP 10



When placing the cap on top of Tandem Wall, use a construction adhesive to secure the cap to the top of the wall.

TANDEM MODULAR BLOCK RETAINING WALL INSTALLATION BEST PRACTICES

STAKE OUT THE WALL

- A surveyor shall locate the proposed base of wall location. Verify the wall location with the project supervisor.

LEVELING PAD

- Excavate for the leveling pad to the lines and grades shown on the approved plans and excavate enough soil behind the wall for geosynthetic reinforcement material, if needed.
- The trench should be approximately 24 inches wide. See Diagram 1.
- Create a leveling pad of compacted base materials that extends a minimum of 6 inches in front of and 6 inches behind the base units. This leveling pad should be at least 6 inches deep after compaction. See Diagram 2.

BASE COURSE

- Install the U Start Base Block with the hand holds down. Place the blocks so the outside curve of one block fits into the curve of the block next to it. Blocks should touch.
- Level blocks front to back and side to side with a dead-blow hammer. See Diagram 3.
- The base course and 2 inches of the wall will be buried.

SYSTEM ASSEMBLY

- Assemble a retaining wall unit by applying the veneer unit to the modular blocks.
- Each modular block has a vertical tenon and each veneer has multiple mortises. The veneer units are joined to the modular blocks by simply sliding the tenon into the mortise to form a retaining wall block.
- Assembly of the retaining wall units always requires the use of two modular blocks for every veneer unit. See Diagram 4.



Diagram 1—Excavation



Diagram 2—Leveling Pad



Diagram 3—Lay and level base block

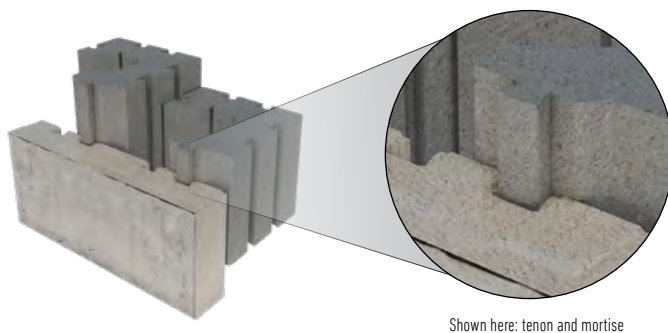

Diagram 4— Assembled units on top of U Start block

Shown here: tenon and mortise

CONSTRUCTION OF 1ST WALL COURSE

- Clean any debris off the top of the U Start base course unit.
- Place the assembled retaining wall unit on top of the U Start Base Block making sure that the first course of wall is centered on the base block.
- For best results, refer to the laying patterns on page 95.
- Check to make sure units are level front to back and side to side on each course.
- Fill cores and voids with $\frac{3}{4}$ -inch free draining aggregate prior to laying the next course of block. See Diagram 5.
- After filling the cores of the units add additional free draining aggregate behind the units extending at least 12 inches behind the blocks. Compact aggregate after each course of block is laid.



Diagram 5—Fill cores with free draining aggregate

CONSTRUCTION OF SUBSEQUENT COURSES AND UNIVERSAL CLIP PLACEMENT

- Clean any debris off the top of the 1st course of wall units.
- Assemble and place the next course of wall units, maintaining a running bond.
- Insert a universal connector in each modular unit with the knuckle towards the soil. Push the connector down until it extends below the bottom of the block to create a $\frac{3}{8}$ " setback. You need one connector per modular unit.
- Push the retaining unit forward until it locks in place. See Diagram 6.
- Level unit front to back and side to side with a dead-blow hammer.
- Fill cores and voids with $\frac{3}{4}$ -inch free draining aggregate prior to laying the next course of block.
- Backfill with $\frac{3}{4}$ -inch free draining aggregate directly behind the block, adding 6 inches at a time followed by proper compaction. Only lightweight hand operated compaction equipment is allowed within 3 feet from the back of the wall.
- Continue each course until the project is complete.



Diagram 6—Lock connector to the block in front



Tandem Universal Connector

STEP 1



STEP 2



STEP 3



RETAINING WALL INSTALLATION BEST PRACTICES

STEPPING UP THE BASE

- Walls built on a sloping grade require a stepped base.
- Begin excavation at the lowest point and dig a level trench into the slope until it is deep enough to accommodate the base material and one entire block.
- At this point, step up the height of one block and begin a new section of base trench. Continue to step-up as needed to top of slope. Always bury at least one full unit at each step. See Diagram 7.



Diagram 7—Stepping up the base

DRAINAGE (PER PLAN)

- Each project is unique. The grades on the site will determine at what level to install the drainpipe. Place the drainpipe (4-inch perforated piping) so water drains down and away from the wall into a storm drain, or daylight just above grade. See Diagram 8.
- Fill in the area behind the blocks with clean drainage aggregate, at least 1 foot from the wall. You may need to place and backfill several courses to achieve the proper drainage level.
- The outlet pipes should be spaced not more than every 50 feet and at low points of the wall. In order for the drainage aggregate to function properly, it must keep clear of regular soil fill.



Diagram 8—Daylight

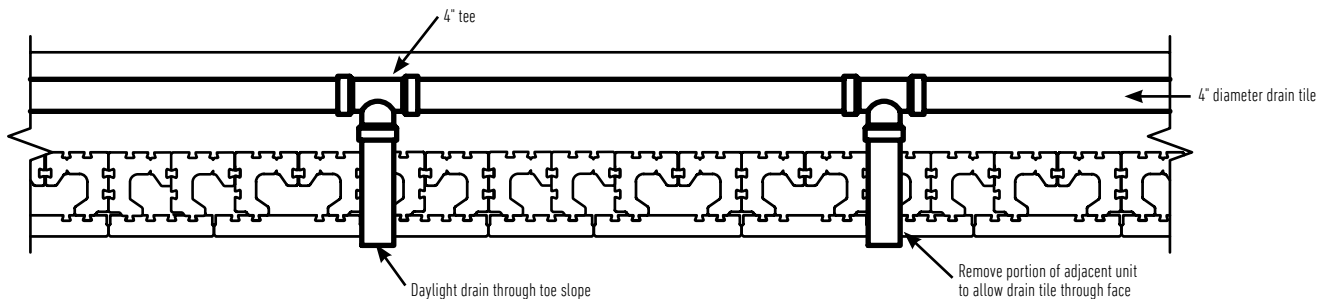

REINFORCED BACKFILL PLACEMENT AND COMPACTION (PER PLAN)

- Place reinforced backfill in 6 to 8 inch loose lifts and compact to the densities specified on the approved wall constructions plans. See Diagram 9.
- Only hand operated compaction equipment is allowed within 3 feet of the back of the wall.
- If the compaction equipment is too small to achieve the required compaction, thinner lifts should be used.
- Install each subsequent course in a similar manner. Repeat procedure to the extent of the wall height.



Diagram 9—Compaction

GEOSYNTHETIC REINFORCEMENT PLACEMENT (PER PLAN) BATTERED WALL INSTALLATION ONLY

- Refer to the approved wall construction plans for the reinforcement type, strength, and placement location. Measure and cut the reinforcement to the lengths shown on the plans.
- Ensure the reinforced backfill is placed and compacted flush with the top of the units and is graded reasonably flat prior to reinforcement placement. Clean any debris off the top layer of blocks prior to reinforcement placement.
- The reinforcement has a primary strength direction, which must be laid perpendicular to the wall face.
- Place the reinforcement within 1 inch of the front of the units. See Diagram 9.
- Apply the next course of blocks to secure the reinforcement in place. Insert Universal Connector into one of the mortise on the back of the modular block to create the proper setback. Pull the reinforcement hand taut and place staples, stakes, or fill at the back of the reinforcement to keep tension during placement of drainage aggregate and reinforced backfill.
- Place a minimum of 6 inches of reinforced backfill prior to operating equipment above the reinforcement. Avoid sudden braking or turning on fill placed over the reinforcement.



Diagram 9—Action



Diagram 10—Low permeable soil

FINISH GRADE AND SURFACE DRAINAGE

- Protect the wall with a finished grade at the top and bottom. To ensure proper water drainage away from the wall, use 6 inches of soil with low permeability and seed or plant to stabilize the surface. See Diagram 10.
- Consult the wall design engineer if water may be directed behind the wall. If needed, create a swale to divert water away from the wall. This will minimize water seeping into the soil and drainage aggregate behind the wall.

SITE CLEANING AND RESTORATION

- Brush off the wall and pick up any debris left from the construction process. Notify the job superintendent in writing of the completion and that it is ready for final inspection and acceptance.
- Planting vegetation in front and on top of the wall will help reduce the chance of erosion.
- Following these best practices for construction will ensure the success of your retaining wall system. These instructions are meant as general guidelines. Site-specific conditions may warrant additional installation requirements.
- Oldcastle® recommends you consult a professional engineer to design walls over 4 feet high, and have compaction tested by a qualified geotechnical engineer.

CAPPING A WALL

CAPPING WALL

Always start capping from the lowest elevation. Once caps are aligned, caps should be glued in place using a concrete adhesive.

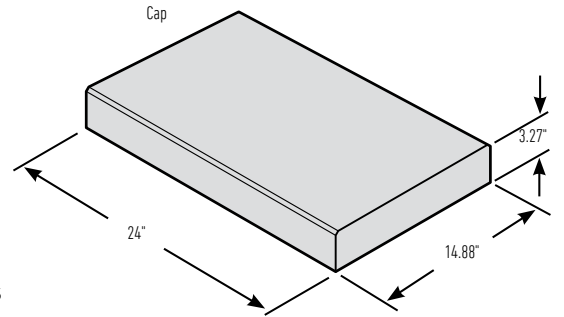

CURVES

Lay out the cap units side by side with the same face facing out. If there's a need to adjust for project's radius, make cuts at least every other cap as needed for the most pleasing aesthetic.

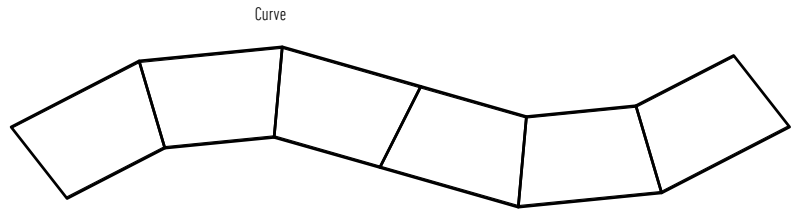
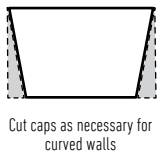

90-DEGREE CORNERS

Saw-cut two caps to achieve a 45-degree mitered corner. See Diagram 11.

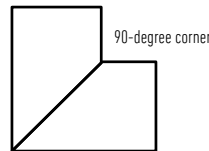
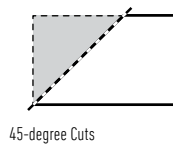
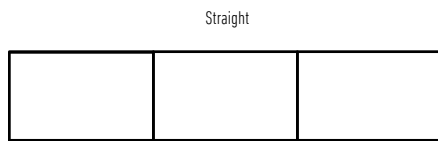
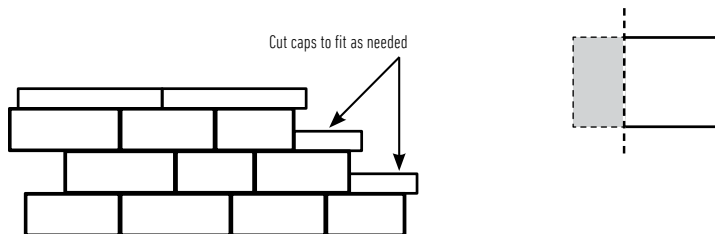

Diagram 11—45-degree miter

STEPPING THE CAP

Saw-cut caps to size depending on ending sized block. Allow at least a 2 inch overhang of the cap on each end. Keep cut end facing inward toward wall.



STEPS

STEPS

- Steps can be constructed by creating layers of step landings
- The base landing is created by connecting multiple modular block together
- The size of the landing varies based on the number of risers to be constructed
- Once the Modular Blocks are laid, the veneer to be used as the riser are joined to the modular block by sliding the tenon into the mortise. If you want to have veneer on the side, use the Universal Clips to attached the veneer to the modular block.
- A second course of steps are constructed above the first course and glued with a concrete adhesive.
- Construction continues until desired number of risers is reached
- Cap the risers with a cap of choice
- Clean stone must be installed behind the structural units. It is also recommended to install clean stone in the empty spaces of the modular block.



TYPICAL CROSS-SECTION: FILL SCENARIO

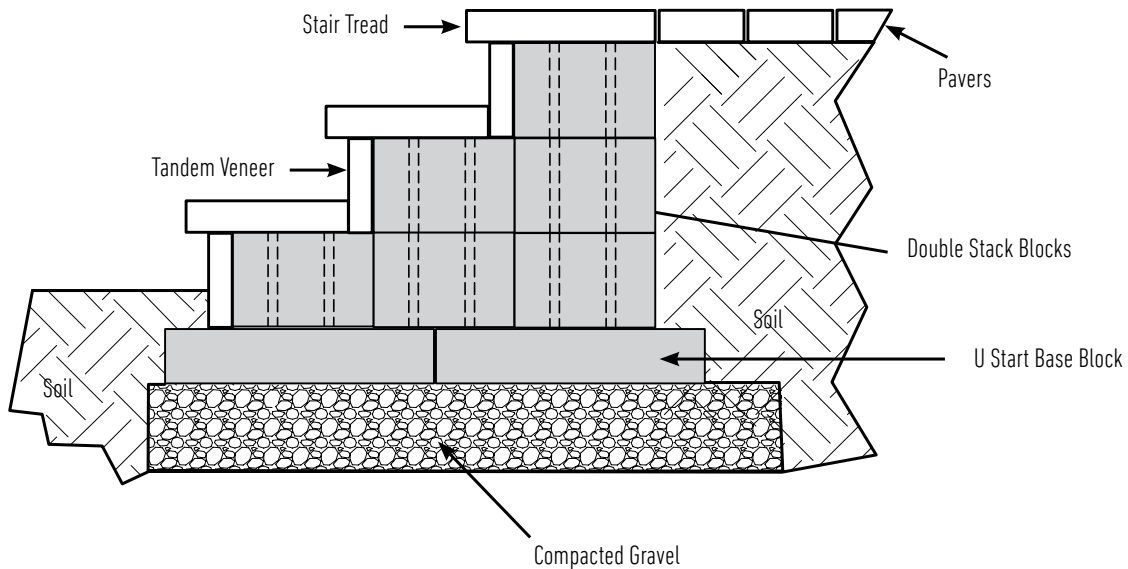

OUTSIDE CURVES & INSIDE CURVES

CURVES

- Building a 6 foot radius curved wall is possible by using full and partial modular block.
- To achieve a tighter radius only use the small and medium veneers.
- To create a partial Modular Block, split the block at the break line using a dead blow hammer. See illustration to the right.
- The minimum radius of an outside curved wall is 6 feet; 8 feet (Lamina).
- Note: the Lamina veneer is not recommended for curved retaining walls.

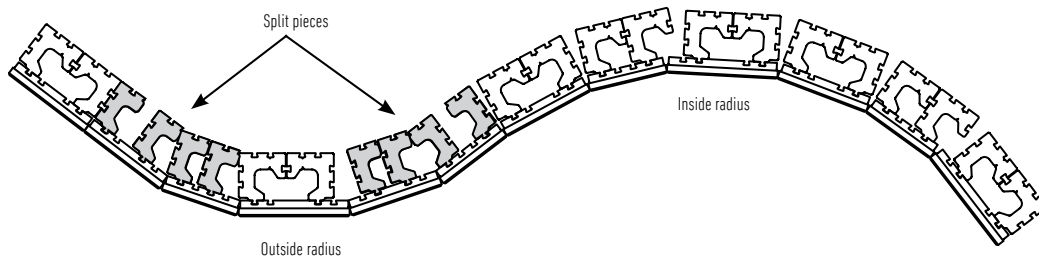

GEOSYNTHETIC REINFORCEMENT PLACEMENT - 1ST COURSE

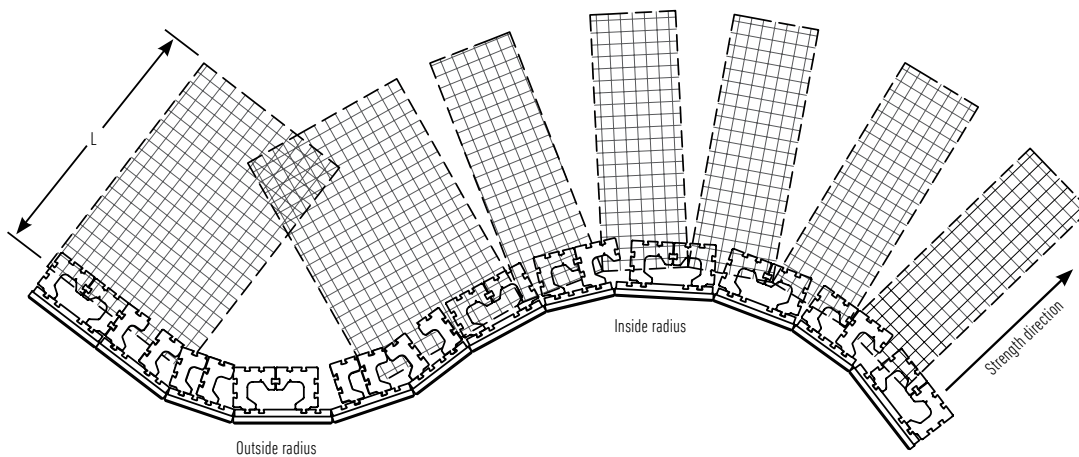

GEOSYNTHETIC REINFORCEMENT PLACEMENT - 2ND COURSE

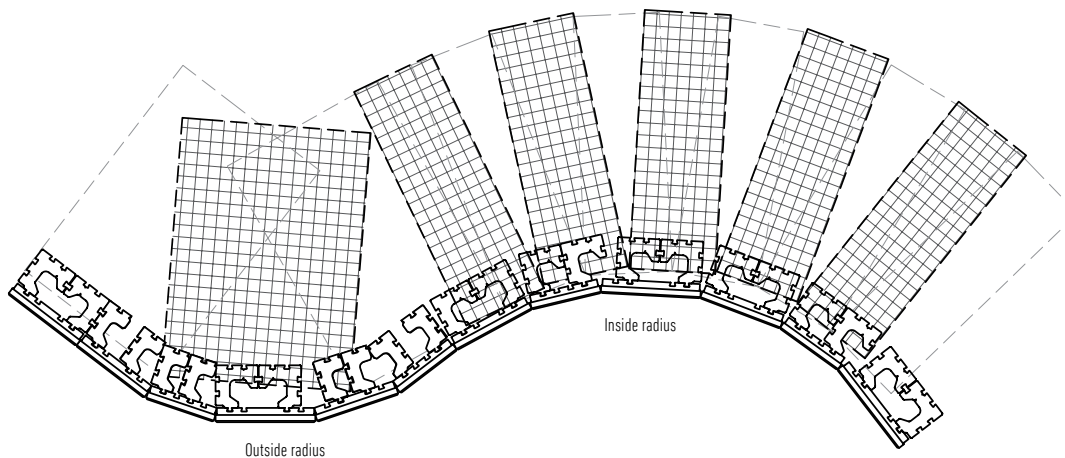

INSIDE 90-DEGREE CORNERS

CORNERS

- The veneer units are reversible to form inside or outside corners
- Corner veneers have finished end. See pallet layout below.
- The corner unit is formed by applying the veneer to the Modular Block using the Universal Connector. See Diagram 12.
- The position of the corner unit is alternated 90° from course to course
- Once corner units are in position, glue with a concrete adhesive
- Additional Modular Blocks can be installed to reinforce the corner



Diagram 12—Corner unit formed

TOP VIEW OF PALLET LAYOUT.

Corner units identified in orange triangle

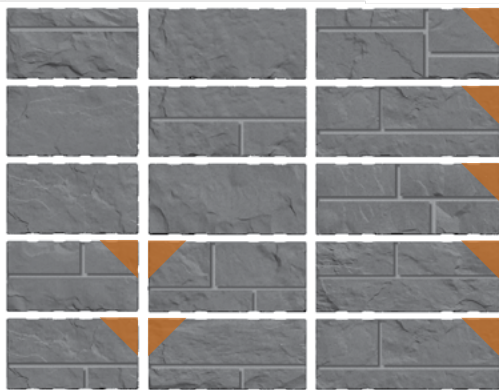

Finished End
(Corner Unit)



Unfinished End

GEOSYNTHETIC REINFORCEMENT PLACEMENT

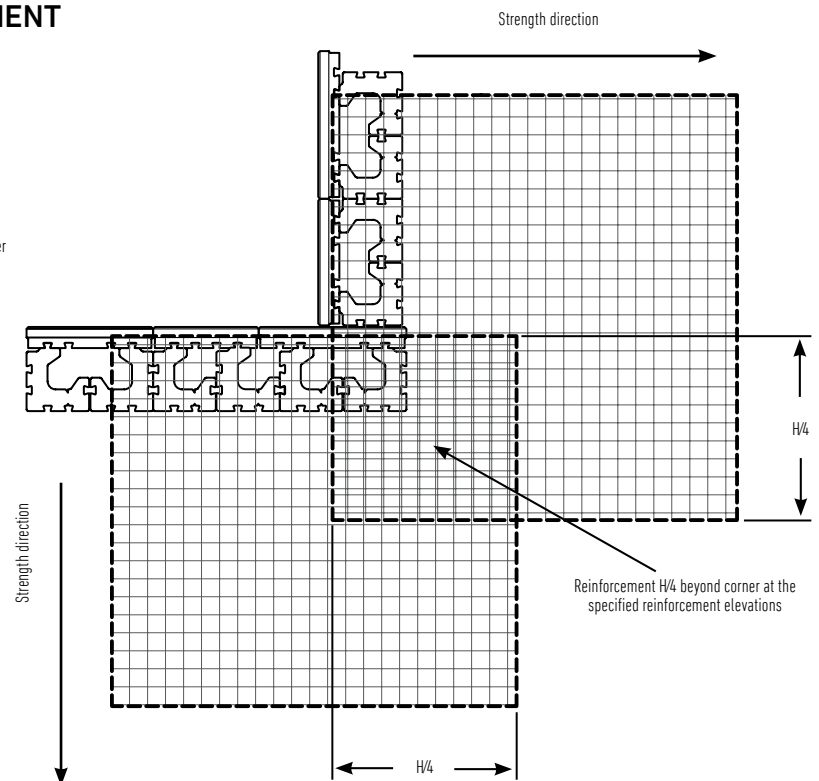
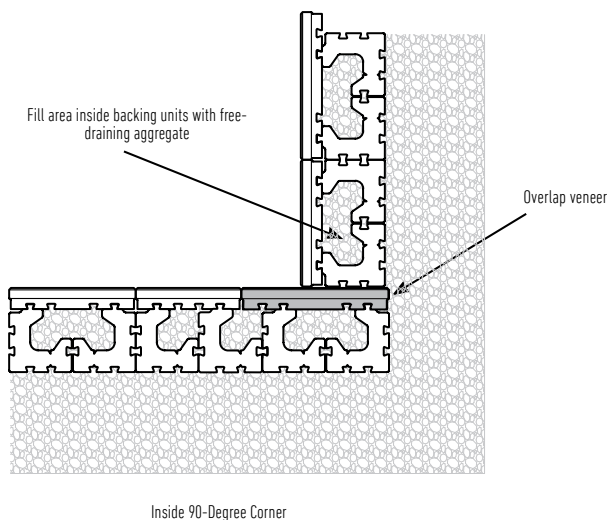

OUTSIDE 90-DEGREE CORNERS

CORNERS

- The veneer units are reversible to form inside or outside corners
- Corner veneers have a finished end and a unfinished end.
See pallet layout below.
- The corner unit is formed by applying the veneer to the Modular Block using the Universal Connector.
- The position of the corner unit is alternated 90° from course to course
- Once corner units are in position, glue with a concrete adhesive.
- Additional Modular Blocks can be installed to reinforce the corner.
See Diagram 13.

TOP VIEW OF PALLET LAYOUT.

Corner units identified in orange triangle

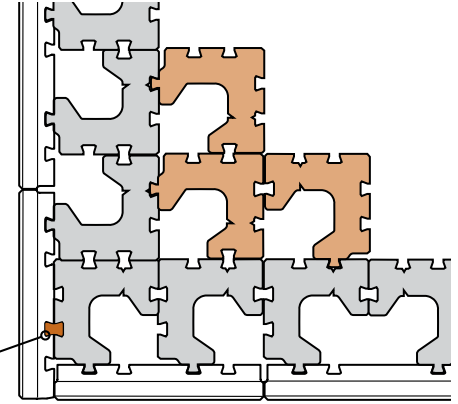
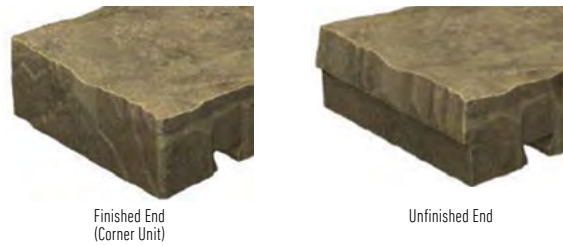
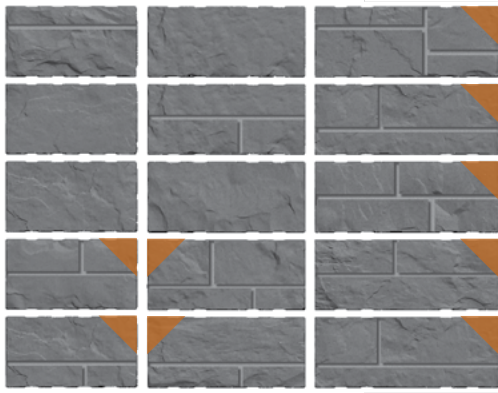
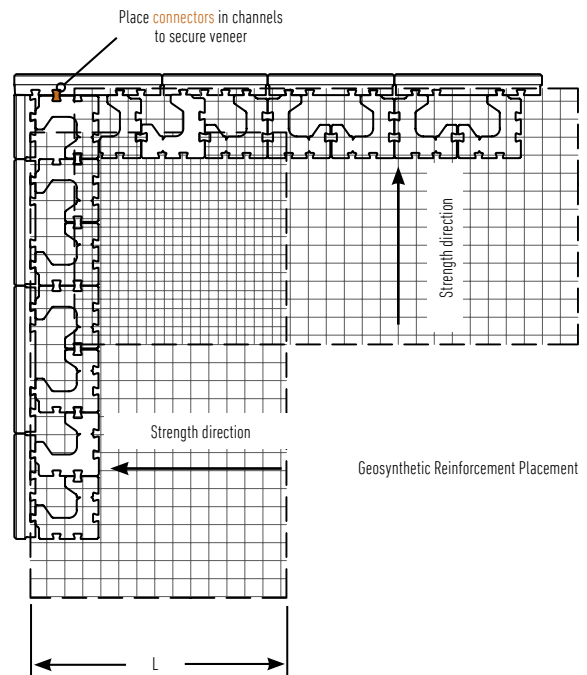
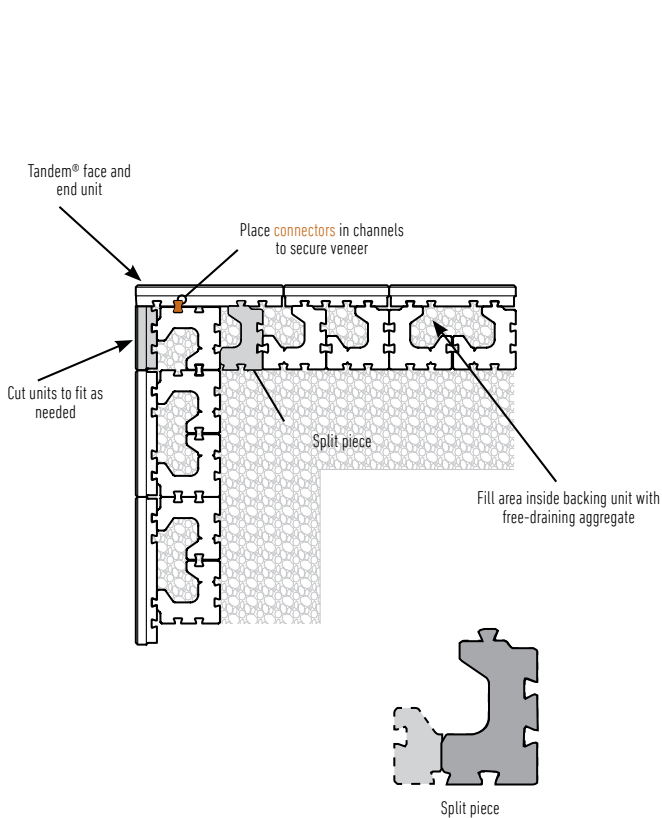

Diagram 13—Additional units for reinforced corner

Place connectors in channels to secure veneer



NOTE: In the "cross-over area" of the reinforcement, one of the layers of reinforcement should be lowered or raised one course to allow placement of the reinforcement strength direction properly oriented. The reinforcement should not extend into the segmental retaining wall units on the return leg of the 90-degree corner.

MULTI STACK WALLS AND TERRACED WALLS

MULTI STACK WALL

The maximum gravity wall height for a retaining wall constructed with the Tandem Modular Block is 3 feet. The flexibility of the Tandem Modular Block allows you to connect the blocks to increase the depth of the retaining wall unit which allows a wall to be constructed higher than 3 feet without the need for geosynthetic reinforcement. Connect the blocks by sliding the vertical tenon into the mortise at the back of the modular block. See Diagram 14, 15 & 16.

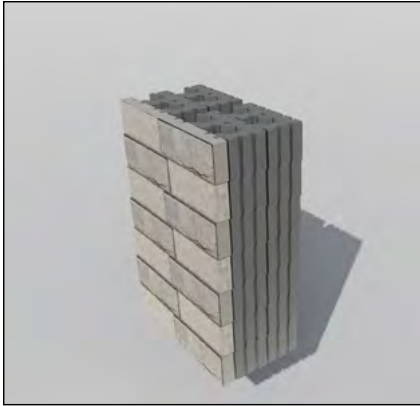

Diagram 14—2 deep. Maximum height of 4 feet

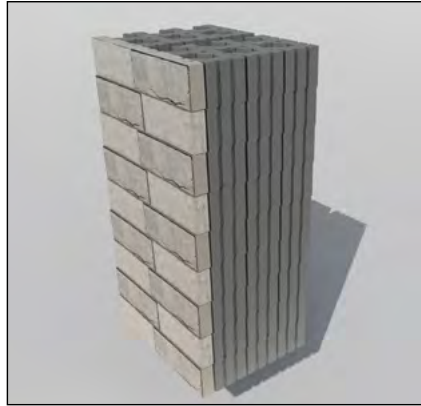

Diagram 15—3 deep. Maximum height of 5½ feet

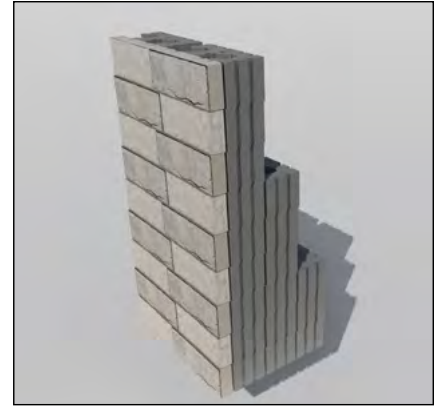
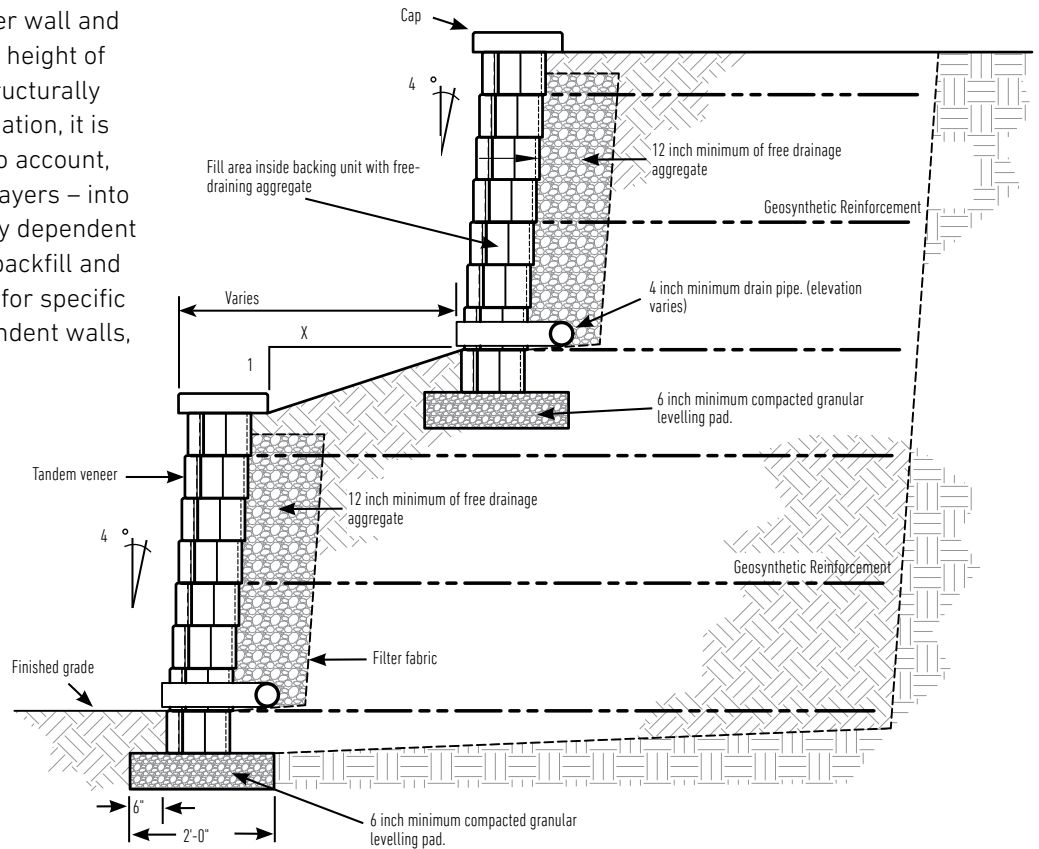

Diagram 16—3 deep, 2 deep & 1 deep. Maximum height of 4½ feet

DEPENDENT TERRACED WALLS

When the distance between the lower wall and the upper wall is less than twice the height of the lower wall, the walls become structurally dependent on each other. In this situation, it is important to take global stability into account, incorporating geogrid – and longer layers – into the wall plan. In addition, structurally dependent walls require even more excavation, backfill and time. Be sure to check the wall plan for specific requirements. For structurally dependent walls, consult with a qualified engineer.



TANDEM MODULAR BLOCK FREESTANDING WALL INSTALLATION BEST PRACTICES

STAKE OUT THE WALL

- A surveyor shall locate the proposed base of wall location. Verify the wall location with the project supervisor.

LEVELING PAD

- Excavate for the leveling pad to the lines and grades shown on the approved plans and excavate enough soil behind the wall for geosynthetic reinforcement material, if needed.
- The trench should be approximately 24 inches wide. See Diagram 17.
- Create a leveling pad of compacted base materials that extends a minimum of 6 inches in front of and 6 inches behind the base units. This leveling pad should be at least 6 inches deep after compaction. See Diagram 18.

BASE COURSE

- Install the U Start Base Block with the hand holds down. Place the blocks so the outside curve of one block fits into the curve of the block next to it. Blocks should touch.
- Level blocks front to back and side to side with a dead-blow hammer. See Diagram 19.
- The base course and 2 inches of the wall will be buried.

SYSTEM ASSEMBLY

- Assemble a freestanding wall unit by applying the veneer units to both sides of the modular blocks. See Diagram 20.
- Each modular block has a vertical tenon and each veneer has multiple mortises. The veneer units are joined to the modular blocks by simply sliding the tenon into the mortise to form a retaining wall block.
- Assembly of the freestanding wall units always requires the use of two modular blocks for every veneer unit.



Diagram 17—Excavation



Diagram 18—Leveling Pad



Diagram 19—Lay and level base block

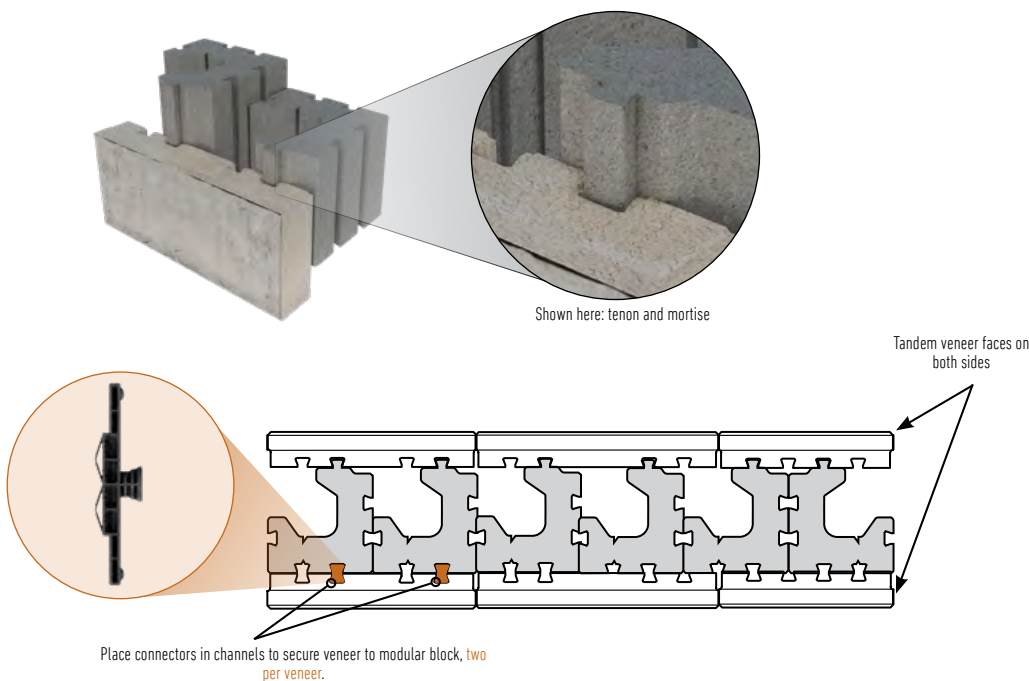

Diagram 20—Placing veneers onto modular block

TANDEM MODULAR BLOCK COURSE CONSTRUCTION & ENDING A WALL WITH & WITHOUT A COLUMN

CONSTRUCTION OF WALL COURSES

To continue with additional courses, assemble units in the same manner as the previous step. Place the assembled units on the course below ensuring that the veneer units are staggered over the bond below. Glue each modular unit to the course below. See Diagram 21.

ENDING A WALL WITHOUT A COLUMN

When finishing a wall end without a column build the wall to the desired length. Install the veneers on one side of the modular units flush to the end. Install the veneer on the other side extending past the modular unit by the thickness of one veneer. Make sure the exposed end of the veneer is the natural edge and not the manufactured edge. Line up and mark a unit to be cut to finish the end of the wall. See illustration below. Make sure to cut off the manufactured edge leaving the natural edge exposed. Install this cut unit inserting two universal connectors into the grooves in both the modular unit and the veneer. See Diagram 22.



Diagram 21—Second course construction



Diagram 22—Wall end example

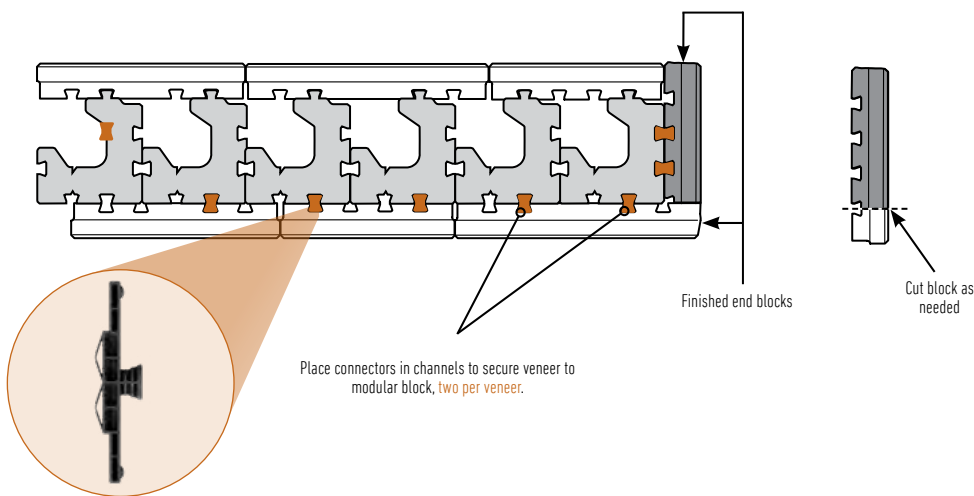

ENDING A WALL WITH A COLUMN

To end a free-standing wall with a column, start by constructing the first course of the column. Using four Modular units, interlock them with the tongue and groove. See Diagram 24 on the next page. Add four large veneer units to this assembly utilizing universal connectors for each veneer. Start building the wall flush to, and centered on the assembled column units. Add the veneer units to the wall and build to length. See Diagram 25. Add the second course of column in a similar fashion rotating the bond at the corners. Continue with the second course of wall. Continue in this fashion until you reach the desired height of column and wall.



Finished End (Corner Unit)



Diagram 23—Ending a wall at a column example

TANDEM MODULAR BLOCK - COLUMNS

To build a column you start by excavating 12 inches below grade and installing an aggregate leveling pad 6 inches thick after compaction and extends at least 6 inches on each side beyond the column dimension. Install 4 U-Start base blocks on the aggregate pad leveling front to back and side to side. Using four Modular units, create your first course of column by interlocking the tongue and groove system together forming an approximate 16-inch by 16-inch square formation. See Diagram 24. Attach a large veneer to each side of your column using 2 universal connectors on each veneer. Make sure the one end of the veneer that protrudes beyond the edge has the natural edge exposed and not the manufactured edge. Using 4 more Modular units build the second course in the same manner using Structurebond between the course to secure them in place. Attach 4 veneers to this course making sure to stagger the bonds at the corners and ensure that all exposed ends are the natural ends and not the manufactured ends. See Diagram 25. Continue to build your column to the desired height.

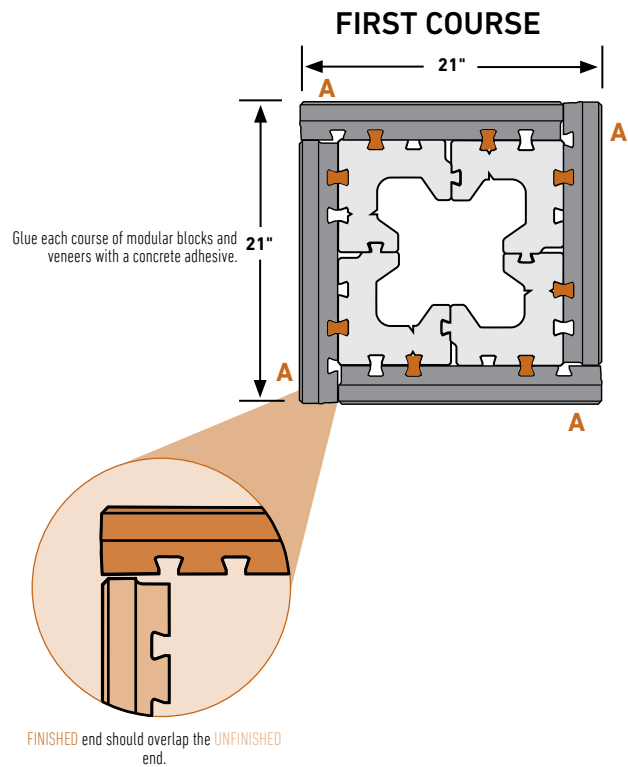

Diagram 24—Connector locations

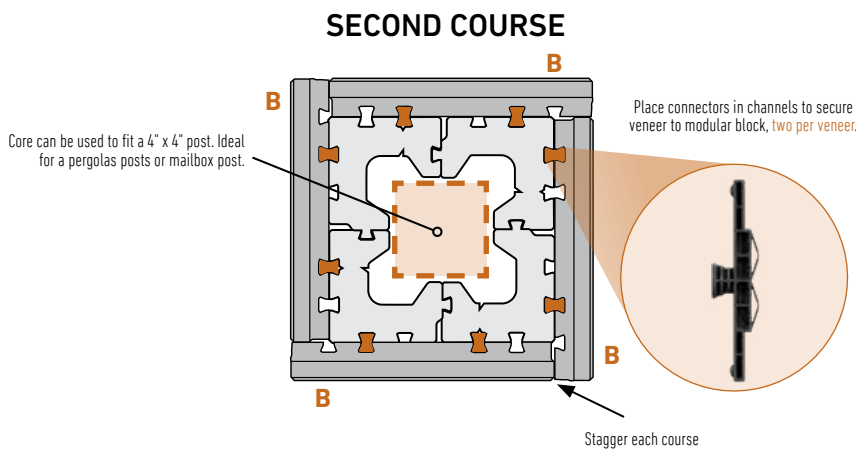









Diagram 25—Stagger veneers to break up lines



Scan for additional product information

RESIDENTIAL	COMMERCIAL	STEPS	COLUMNS	FIRE PITS	KITCHEN	FREESTANDING WALL	RETAINING WALL
							
✓	✓	✓	✓	✓	✓	✓	✓

SHAPES & SIZES

3-Piece



6 x 6 / 4 x 10



6 x 12 / 10 x 10



6 x 16 / 14 x 10



2³/₈ x 10 x 12

Westgate Cap

UNIT	SQFT/PALLET	SQFT/LAYER	LAYER/PALLET	UNITS/PALLET	UNITS/LAYER	UNITS/SQFT	WEIGHT/PALLET
------	-------------	------------	--------------	--------------	-------------	------------	---------------

3-PIECE









6 X 6 / 4 X 10	5.25	1.05	–	25	5	4	–
6 X 12 / 10 X 10	11.45	2.29	–	25	5	2	–
6 X 16 / 14 X 10	15.625	3.125	–	25	5	1.5	–
TOTAL	32.3	6.46	5	75	15	–	3431

WESTGATE CAP

2 ³ / ₈ X 10 X 12	–	–	5	80	16	–	1760
---	---	---	---	----	----	---	------



Scan for additional
product information

RESIDENTIAL	COMMERCIAL	STEPS	COLUMNS	FIRE PITS	KITCHEN	FREESTANDING WALL	RETAINING WALL
							
✓	✓	✓	✓				✓

SHAPES & SIZES

Pro 9D

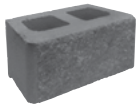

8 x 18 x 9

PS



8 x 18 x 12

Corner



8 x 18 x 8

Cap

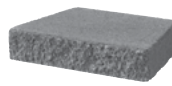

4 x 18 x 12

UNIT	SQFT/ PALLET	SQFT/ LAYER	LAYER/ PALLET	UNITS/ PALLET	UNITS/ LAYER	UNITS/ SQFT	WEIGHT/ PALLET
PRO 9D							
8 X 18 X 9	48	12	4	48	12	1	2880
PS							
8 X 18 X 12	45	9	5	45	9	1	3667
CORNER							
8 X 18 X 8	–	–	5	50	10	–	5250
CAP							
4 X 18 X 12	–	–	7	56	8	.667 LNFT	3808





Scan for additional
product information

RESIDENTIAL	COMMERCIAL	STEPS	COLUMNS	FIRE PITS	KITCHEN	FREESTANDING WALL	RETAINING WALL
✓	✓	✓	✓	✓	✓	✓	✓

SHAPES & SIZES

2-Piece FSW



6 x 6 / 4 x 9



6 x 12 / 10 x 9



6 x 18 / 16 x 9



6 x 18 x 9

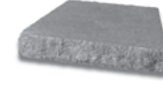

3 x 17¼ x 10¾



6 x 18 x 9

UNIT	SQFT/ PALLET	SQFT/ LAYER	LAYER/ PALLET	UNITS/ PALLET	UNITS/ LAYER	UNITS/ SQFT	WEIGHT/ PALLET
------	-----------------	----------------	------------------	------------------	-----------------	----------------	-------------------

2-PIECE FSW

7 X 13¾ X 3	8.32	2.08	–	40	10	0.208	–
7 X 15¾ X 3	18.32	4.58	–	40	10	0.458	–
TOTAL	26.8	6.7	4	80	20	–	2750

18" FSW

6 X 18 / 16 X 9	35.5	7.1	5	50	10	1.411	3550
-----------------	------	-----	---	----	----	-------	------

SRW

6 X 18 X 9	44.5	8.9	5	60	12	1.35	3300
------------	------	-----	---	----	----	------	------

CAP

3 X 17¼ X 10¾	92.08 LNFT	10 LNFT	10	80	8	1.151 LNFT	2880
---------------	------------	---------	----	----	---	------------	------









CORNER

6 X 18 X 9	–	–	5	50	10	–	4000
------------	---	---	---	----	----	---	------





Scan for additional
product information

RESIDENTIAL	COMMERCIAL	STEPS	COLUMNS	FIRE PITS	KITCHEN	FREESTANDING WALL	RETAINING WALL
							
✓	✓	✓	✓	✓	✓	✓	✓

See tandem installation instructions on page XXXXXX

SHAPES & SIZES

3-Piece



7 x 13²/₃ x 3

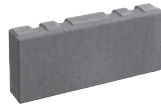

7 x 15²/₃ x 3



7 x 18²/₃ x 3

Cap



15 x 24 x 3¹/₄

Modular Block



7¹/₁₆ x 7⁷/₈ x 7⁷/₈

UNIT	SQFT/ PALLET	SQFT/ LAYER	LAYER/ PALLET	UNITS/ PALLET	UNITS/ LAYER	UNITS/ SQFT	WEIGHT/ PALLET
3-PIECE							
7 X 13 ² / ₃ X 3	19.2	–	–	30	5	1.56	–
7 X 15 ² / ₃ X 3	23.1	–	–	30	5	1.3	–
7 X 18 ¹ / ₂ X 3	27	–	–	30	5	1.1	–
TOTAL	70	11.7	6	90	15	–	2082
CAP							
15 X 24 X 3 ¹ / ₄	–	–	5	32	16	–	2990
MODULAR BLOCK							
4 X 20 X 10	48.64	12.16	4	128	32	2.6	2816



Scan for additional
product information

RESIDENTIAL	COMMERCIAL	STEPS	COLUMNS	FIRE PITS	KITCHEN	FREESTANDING WALL	RETAINING WALL
							
✓	✓	✓	✓	✓	✓	✓	✓

SHAPES & SIZES

Wall Block



4 x 20 x 10

Cap

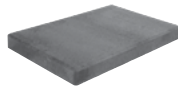

2 x 20 x 13

UNIT	SQFT/ PALLET	SQFT/ LAYER	LAYER/ PALLET	UNITS/ PALLET	UNITS/ LAYER	UNITS/ SQFT	WEIGHT/ PALLET
------	-----------------	----------------	------------------	------------------	-----------------	----------------	-------------------

WALL BLOCK









4 X 20 X 10	26.9	4.483	6	48	8	.55	2976
-------------	------	-------	---	----	---	-----	------

CAP

2 X 20 X 13	100 LNFT	–	10	60	6	0.6 LNFT	2460
-------------	----------	---	----	----	---	----------	------



Scan for additional product information

RESIDENTIAL	COMMERCIAL	STEPS	COLUMNS	FIRE PITS	KITCHEN	FREESTANDING WALL	RETAINING WALL
							
✓	✓	✓	✓	✓	✓	✓	✓

SHAPES & SIZES

3-Piece



4 x 8 x 5



4 x 12 x 9



4 x 16 x 13

Universal



4 x 12 x 8

Westgate Cap



2 3/8 x 10 x 12

UNIT	SQFT/PALLET	SQFT/LAYER	LAYER/PALLET	UNITS/PALLET	UNITS/LAYER	UNITS/SQFT	WEIGHT/PALLET
------	-------------	------------	--------------	--------------	-------------	------------	---------------

3-PIECE

4 X 8 X 5	9.24	1.32	–	42	6	4.55	–
4 X 12 X 9	13.86	1.98	–	42	6	3.03	–
4 X 16 X 13	18.9	2.7	–	42	6	2.22	–
TOTAL	42	6	7	126	18	–	3276

UNIVERSAL

4 X 12 X 10	39.96	6.66	120	6	20	3.003	3360
-------------	-------	------	-----	---	----	-------	------

WESTGATE CAP

2 3/8 X 10 X 12	–	–	5	80	16	–	1760
-----------------	---	---	---	----	----	---	------

WESTON STONE™ INSTALLATION INSTRUCTIONS

This is a pinless system. Maximum wall height is 2½ feet. Walls exceeding 2½ feet in height may require geogrid reinforcing and the consultation of a qualified engineer. Contact your Belgard sales representative or dealer for assistance.

Weston Stone wall units must be glued with a quality construction adhesive to develop the necessary mechanical bond. All measurements herein are approximate. Natural materials are used in the manufacturing of this product.

TYPICAL CROSS SECTION WITH WESTON STONE SEAT WALL

TREE RINGS WITH WESTON STONE

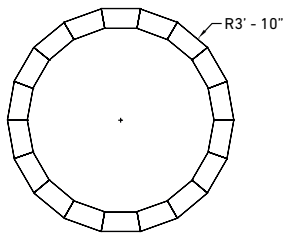
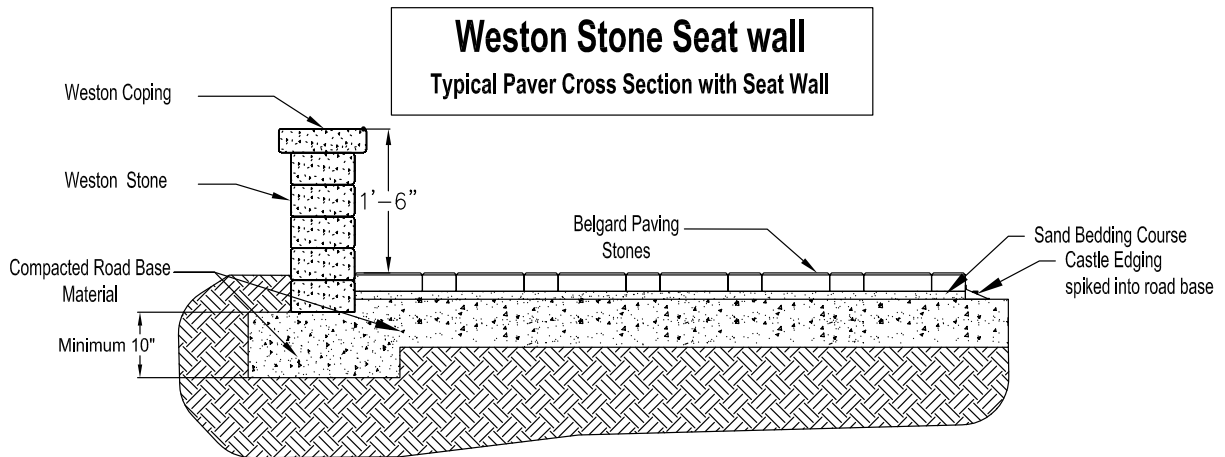

Large Units
Outside Radius: 3' - 10"
Outside Diameter: 7' - 8"

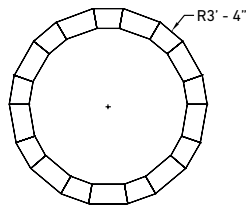

Large & Medium Units
Outside Radius: 3' - 4"
Outside Diameter: 6' - 8"

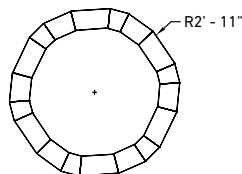

Large, Medium & Small Units
Outside Radius: 2' - 11"
Outside Diameter: 5' - 10"

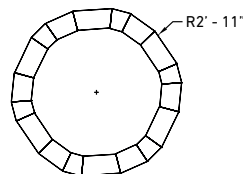

Large, Medium & Small Units
Outside Radius: 2' - 11"
Outside Diameter: 5' - 10"

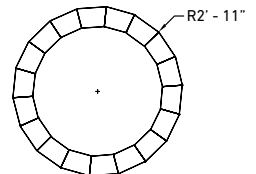

Medium Units
Outside Radius: 2' - 11"
Outside Diameter: 5' - 10"

Estimating Chart for Geosynthetic Reinforcement with Diamond® Series, Highland Stone® Retaining Wall Systems

No Slopes & No Surcharges

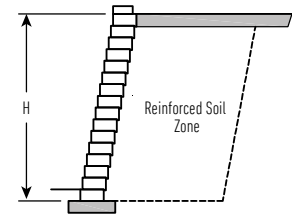

	CLAY & SILT SOILS $\phi = 26^\circ$ $\gamma = 120 \text{ pcf (19kN/m}^3\text{)}$	SILTY/CLAYEY SAND SOIL $\phi = 30^\circ$ $\gamma = 120 \text{ pcf (19kN/m}^3\text{)}$	CLEAN SAND AND GRAVEL SOIL $\phi = 34^\circ$ $\gamma = 120 \text{ pcf (19kN/m}^3\text{)}$
4'-0" (1200mm) 8 courses	<p>4.5-FT (1350mm) 4.5-FT (1350mm) 4.5-FT (1350mm) 4.5-FT (1350mm)</p>	<p>4.0-FT (1350mm) 4.0-FT (1350mm)</p>	<p>4.0-FT (1350mm) 4.0-FT (1350mm)</p>
6'-0" (1800mm) 12 courses	<p>6.5-FT (1950mm) 6.5-FT (1950mm) 6.5-FT (1950mm) 6.5-FT (1950mm) 6.5-FT (1950mm) 6.5-FT (1950mm)</p>	<p>5.0-FT (1500mm) 5.0-FT (1500mm) 5.0-FT (1500mm)</p>	<p>4.5-FT (1350mm) 4.5-FT (1350mm) 4.5-FT (1350mm)</p>
8'-0" (2400mm) 16 courses	<p>7.5-FT (2250mm) 7.5-FT (2250mm) 7.5-FT (2250mm) 7.5-FT (2250mm) 7.5-FT (2250mm) 7.5-FT (2250mm) 7.5-FT (2250mm) 7.5-FT (2250mm)</p>	<p>6.0-FT (1800mm) 6.0-FT (1800mm) 6.0-FT (1800mm) 6.0-FT (1800mm)</p>	<p>6.0-FT (1800mm) 6.0-FT (1800mm) 6.0-FT (1800mm) 6.0-FT (1800mm)</p>
10'-0" (3000mm) 20 courses	<p>8.5-FT (2550mm) 8.5-FT (2550mm) 8.5-FT (2550mm) 8.5-FT (2550mm) 8.5-FT (2550mm) 8.5-FT (2550mm) 8.5-FT (2550mm) 8.5-FT (2550mm) 8.5-FT (2550mm) 8.5-FT (2550mm)</p>	<p>7.5-FT (2250mm) 7.5-FT (2250mm) 7.5-FT (2250mm) 7.5-FT (2250mm) 7.5-FT (2250mm)</p>	<p>7.0-FT (2100mm) 7.0-FT (2100mm) 7.0-FT (2100mm) 7.0-FT (2100mm) 7.0-FT (2100mm)</p>
12'-0" (3600mm) 24 courses	<p>WALL DESIGN TO BE PERFORMED BY A PROFESSIONAL ENGINEER</p>	<p>8.5-FT (2550mm) 8.5-FT (2550mm) 8.5-FT (2550mm) 8.5-FT (2550mm) 8.5-FT (2550mm) 8.5-FT (2550mm)</p>	<p>8.0-FT (2400mm) 8.0-FT (2400mm) 8.0-FT (2400mm) 8.0-FT (2400mm) 8.0-FT (2400mm) 8.0-FT (2400mm)</p>

Estimating Chart for Geosynthetic Reinforcement with Diamond® Series, Highland Stone® Retaining Wall Systems 250 PSF Surcharge

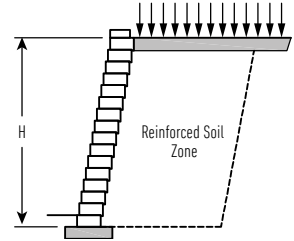

	CLAY & SILT SOILS $\phi = 26^\circ$ $\gamma = 120 \text{ pcf } (19\text{kN/m}^3)$	SILTY/CLAYEY SAND SOIL $\phi = 30^\circ$ $\gamma = 120 \text{ pcf } (19\text{kN/m}^3)$	CLEAN SAND AND GRAVEL SOIL $\phi = 34^\circ$ $\gamma = 120 \text{ pcf } (19\text{kN/m}^3)$
4'-0" (1200 mm) 8 courses			
6'-0" (1800 mm) 12 courses			
8'-0" (2400 mm) 16 courses			
10'-0" (3000 mm) 20 courses			
12'-0" (3600 mm) 24 courses			

Estimating Chart for Geosynthetic Reinforcement with Diamond® Series, Highland Stone® Retaining Wall Systems

3:1 Crest Slope

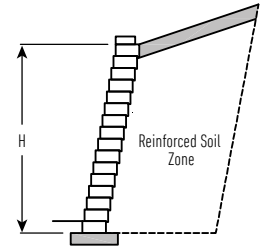

	CLAY & SILT SOILS $\phi = 26^\circ$ $\gamma = 120 \text{ pcf } (19\text{kN/m}^3)$	SILTY/CLAYEY SAND SOIL $\phi = 30^\circ$ $\gamma = 120 \text{ pcf } (19\text{kN/m}^3)$	CLEAN SAND AND GRAVEL SOIL $\phi = 34^\circ$ $\gamma = 120 \text{ pcf } (19\text{kN/m}^3)$
4'-0" (1200mm) 8 courses			
6'-0" (1800mm) 12 courses			
8'-0" (2400mm) 16 courses			
10'-0" (3000mm) 20 courses			
12'-0" (3600mm) 24 courses			

Estimating Chart for Structural Backfill Using Grid with Diamond® Series, (6") Highland Stone® Retaining Wall Systems No Slope / No Surcharge

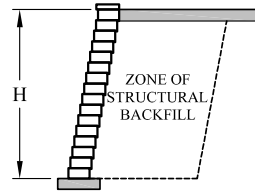

	Clay and Silt Soils $\phi = 26^\circ$ $\gamma = 120 \text{ pcf (19 kN/m}^3\text{)}$	Silty / Clayey Sand Soil $\phi = 30^\circ$ $\gamma = 120 \text{ pcf (19 kN/m}^3\text{)}$	Clean Sand and Gravel Soil $\phi = 34^\circ$ $\gamma = 120 \text{ pcf (19 kN/m}^3\text{)}$
4'-0" (1200 mm) 6 Courses	<p>1'-0" [300 mm]</p> <p>0.22 x Wall Length = CY of Structural Backfill</p>	<p>1'-0" [300 mm]</p> <p>0.22 x Wall Length = CY of Structural Backfill</p>	<p>1'-0" [300 mm]</p> <p>0.22 x Wall Length = CY of Structural Backfill</p>
6'-0" (1800 mm) 9 Courses	<p>1'-6" [450 mm]</p> <p>0.44 x Wall Length = CY of Structural Backfill</p>	<p>1'-0" [300 mm]</p> <p>0.33 x Wall Length = CY of Structural Backfill</p>	<p>1'-0" [300 mm]</p> <p>0.33 x Wall Length = CY of Structural Backfill</p>
8'-0" (2400 mm) 12 Courses	<p>2'-6" [750 mm]</p> <p>0.89 x Wall Length = CY of Structural Backfill</p>	<p>2'-0" [600 mm]</p> <p>0.74 x Wall Length = CY of Structural Backfill</p>	<p>2'-0" [600 mm]</p> <p>0.74 x Wall Length = CY of Structural Backfill</p>
10'-0" (3000 mm) 15 Courses	<p>3'-0" [900 mm]</p> <p>1.30 x Wall Length = CY of Structural Backfill</p>	<p>2'-6" [750 mm]</p> <p>1.11 x Wall Length = CY of Structural Backfill</p>	<p>2'-6" [750 mm]</p> <p>1.11 x Wall Length = CY of Structural Backfill</p>
12'-0" (3600 mm) 18 Courses	<p>4'-0" [1200 mm]</p> <p>2.00 x Wall Length = CY of Structural Backfill</p>	<p>3'-0" [900 mm]</p> <p>1.56 x Wall Length = CY of Structural Backfill</p>	<p>3'-0" [900 mm]</p> <p>1.56 x Wall Length = CY of Structural Backfill</p>

Estimating Chart for Structural Backfill Using Grid with Diamond® Series, (6") Highland Stone® Retaining Wall Systems

250 PSF Surcharge

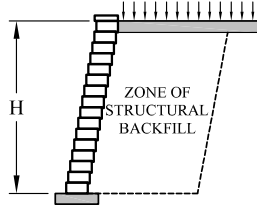

	Clay and Silt Soils $\phi = 26^\circ$ $\gamma = 120 \text{ pcf (19 kN/m}^3\text{)}$	Silty / Clayey Sand Soil $\phi = 30^\circ$ $\gamma = 120 \text{ pcf (19 kN/m}^3\text{)}$	Clean Sand and Gravel Soil $\phi = 34^\circ$ $\gamma = 120 \text{ pcf (19 kN/m}^3\text{)}$
4'-0" (1200 mm) 6 Courses	<p>2'-6" [750 mm]</p> <p>0.44 x Wall Length = CY of Structural Backfill</p>	<p>1'-6" [450 mm]</p> <p>0.30 x Wall Length = CY of Structural Backfill</p>	<p>1'-0" [300 mm]</p> <p>0.22 x Wall Length = CY of Structural Backfill</p>
6'-0" (1800 mm) 9 Courses	<p>3'-6" [1050 mm]</p> <p>0.89 x Wall Length = CY of Structural Backfill</p>	<p>2'-0" [600 mm]</p> <p>0.56 x Wall Length = CY of Structural Backfill</p>	<p>1'-0" [300 mm]</p> <p>0.33 x Wall Length = CY of Structural Backfill</p>
8'-0" (2400 mm) 12 Courses	<p>4'-0" [1200 mm]</p> <p>1.33 x Wall Length = CY of Structural Backfill</p>	<p>2'-6" [750 mm]</p> <p>0.89 x Wall Length = CY of Structural Backfill</p>	<p>2'-0" [600 mm]</p> <p>0.74 x Wall Length = CY of Structural Backfill</p>
10'-0" (3000 mm) 15 Courses	<p>Wall design to be performed by a professional engineer</p>	<p>3'-0" [900 mm]</p> <p>1.30 x Wall Length = CY of Structural Backfill</p>	<p>2'-6" [750 mm]</p> <p>1.11 x Wall Length = CY of Structural Backfill</p>
12'-0" (3600 mm) 18 Courses	<p>Wall design to be performed by a professional engineer</p>	<p>3'-6" [1050 mm]</p> <p>1.78 x Wall Length = CY of Structural Backfill</p>	<p>3'-0" [900 mm]</p> <p>1.56 x Wall Length = CY of Structural Backfill</p>

Estimating Chart for Structural Backfill Using Anchorplex System with Diamond® Series, (6") Highland Stone® Retaining Wall Systems

3:1 Crest Slope

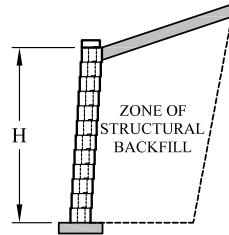







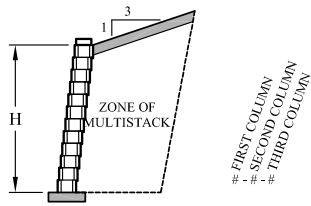
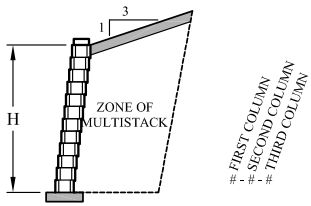
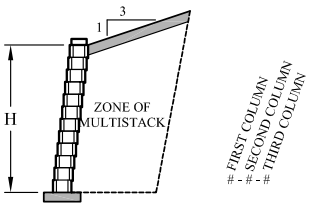

	Clay and Silt Soils $\phi = 26^\circ$ $\gamma = 120 \text{ pcf (19 kN/m}^3\text{)}$	Silty / Clayey Sand Soil $\phi = 30^\circ$ $\gamma = 120 \text{ pcf (19 kN/m}^3\text{)}$	Clean Sand and Gravel Soil $\phi = 34^\circ$ $\gamma = 120 \text{ pcf (19 kN/m}^3\text{)}$
4'-0" (1200 mm) 6 Courses	<p>2'-0" [600 mm]</p> <p>0.37 x Wall Length = CY of Structural Backfill</p>	<p>1'-0" [300 mm]</p> <p>0.22 x Wall Length = CY of Structural Backfill</p>	<p>1'-0" [300 mm]</p> <p>0.22 x Wall Length = CY of Structural Backfill</p>
6'-0" (1800 mm) 9 Courses	<p>3'-6" [1050 mm]</p> <p>0.89 x Wall Length = CY of Structural Backfill</p>	<p>1'-6" [450 mm]</p> <p>0.44 x Wall Length = CY of Structural Backfill</p>	<p>1'-0" [300 mm]</p> <p>0.33 x Wall Length = CY of Structural Backfill</p>
8'-0" (2400 mm) 12 Courses	<p>5'-0" [1500 mm]</p> <p>1.63 x Wall Length = CY of Structural Backfill</p>	<p>2'-6" [750 mm]</p> <p>0.89 x Wall Length = CY of Structural Backfill</p>	<p>2'-0" [600 mm]</p> <p>0.74 x Wall Length = CY of Structural Backfill</p>
10'-0" (3000 mm) 15 Courses	<p>Wall design to be performed by a professional engineer</p>	<p>3'-0" [900 mm]</p> <p>1.30 x Wall Length = CY of Structural Backfill</p>	<p>2'-6" [750 mm]</p> <p>1.11 x Wall Length = CY of Structural Backfill</p>
12'-0" (3600 mm) 18 Courses	<p>Wall design to be performed by a professional engineer</p>	<p>4'-0" [1200 mm]</p> <p>2.00 x Wall Length = CY of Structural Backfill</p>	<p>3'-0" [900 mm]</p> <p>1.56 x Wall Length = CY of Structural Backfill</p>

Estimating Chart for Multi-Stack Walls

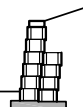
Diamond Pro® Retaining Walls

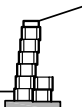
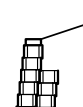
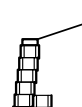
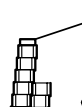
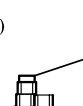

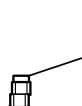
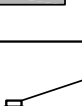
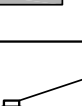
3:1 Crest Slope

CLAY AND SILT SOIL	SILTY/CLAYEY SAND SOIL	CLEAN SAND AND GRAVEL SOIL
<p>H</p> <p>$\phi = 26^\circ$ $\gamma = 120 \text{ pcf} (19 \text{ kN/m}^3)$</p> 	<p>H</p> <p>$\phi = 30^\circ$ $\gamma = 120 \text{ pcf} (19 \text{ kN/m}^3)$</p> 	<p>H</p> <p>$\phi = 34^\circ$ $\gamma = 120 \text{ pcf} (19 \text{ kN/m}^3)$</p> 
<p>4 Courses 2'-8" (800 mm)</p>  <p>4-1-0</p>	<p>4 Courses 2'-8" (800 mm)</p>  <p>MULTISTACK NOT REQUIRED</p>	<p>4 Courses 2'-8" (800 mm)</p>  <p>MULTISTACK NOT REQUIRED</p>
<p>6 Courses 4'-0" (1200 mm)</p>  <p>6-4-0</p>	<p>6 Courses 4'-0" (1200 mm)</p>  <p>6-3-0</p>	<p>6 Courses 4'-0" (1200 mm)</p>  <p>6-2-0</p>
<p>8 Courses 5'-4" (1600 mm)</p>  <p>8-6-3</p>	<p>8 Courses 5'-4" (1600 mm)</p>  <p>8-4-2</p>	<p>8 Courses 5'-4" (1600 mm)</p>  <p>8-5-0</p>
<p>10 Courses 6'-8" (2000 mm)</p>  <p>10-9-7</p>	<p>10 Courses 6'-8" (2000 mm)</p>  <p>10-7-5</p>	<p>10 Courses 6'-8" (2000 mm)</p>  <p>10-7-3</p>
<p>12 Courses 8'-0" (2400 mm)</p> <p>N/A</p>	<p>12 Courses 8'-0" (2400 mm)</p>  <p>12-11-9</p>	<p>12 Courses 8'-0" (2400 mm)</p>  <p>12-9-7</p>

Estimating Chart for Multi-Stack Walls

Diamond Pro® Retaining Walls

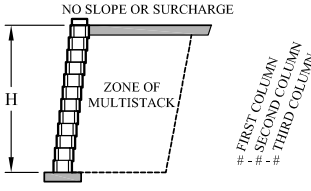
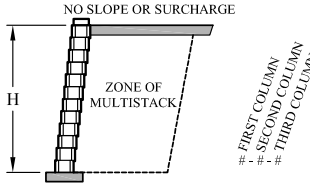
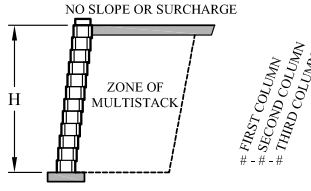
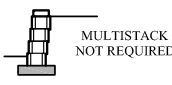
No Slope / No Surcharges

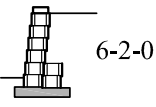
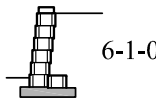
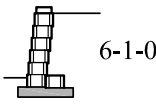
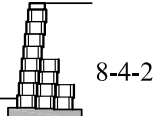
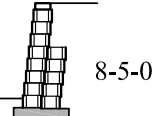
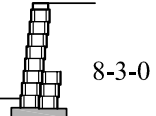
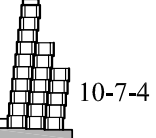
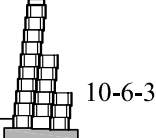
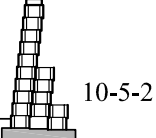
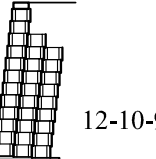
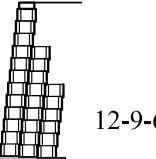
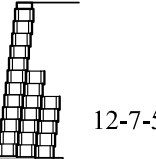
CLAY AND SILT SOIL H $\phi = 26^\circ$ $\gamma = 120 \text{ pcf } (19 \text{ kN/m}^3)$	SILTY/CLAYEY SAND SOIL H $\phi = 30^\circ$ $\gamma = 120 \text{ pcf } (19 \text{ kN/m}^3)$	CLEAN SAND AND GRAVEL SOIL H $\phi = 34^\circ$ $\gamma = 120 \text{ pcf } (19 \text{ kN/m}^3)$
<p>NO SLOPE OR SURCHARGE</p> 	<p>NO SLOPE OR SURCHARGE</p> 	<p>NO SLOPE OR SURCHARGE</p> 
<p>4 Courses 2'-8" (800 mm)</p> 	<p>4 Courses 2'-8" (800 mm)</p> 	<p>4 Courses 2'-8" (800 mm)</p> 
<p>6 Courses 4'-0" (1200 mm)</p> 	<p>6 Courses 4'-0" (1200 mm)</p> 	<p>6 Courses 4'-0" (1200 mm)</p> 
<p>8 Courses 5'-4" (1600 mm)</p> 	<p>8 Courses 5'-4" (1600 mm)</p> 	<p>8 Courses 5'-4" (1600 mm)</p> 
<p>10 Courses 6'-8" (2000 mm)</p> 	<p>10 Courses 6'-8" (2000 mm)</p> 	<p>10 Courses 6'-8" (2000 mm)</p> 
<p>12 Courses 8'-0" (2400 mm)</p> 	<p>12 Courses 8'-0" (2400 mm)</p> 	<p>12 Courses 8'-0" (2400 mm)</p> 

Estimating Chart for Multi-Stack Walls

Diamond Pro® Retaining Walls

250 PSF Surcharge

CLAY AND SILT SOIL	SILTY/CLAYEY SAND SOIL	CLEAN SAND AND GRAVEL SOIL
<p>H</p> <p>$\phi = 26^\circ$ $\gamma = 120 \text{ pcf} (19 \text{ kN/m}^3)$</p> <p>250 PSF (12 KPA) SURCHARGE</p> <p>H</p> <p>ZONE OF MULTISTACK</p> <p># FIRST COLUMN # SECOND COLUMN # THIRD COLUMN</p>	<p>H</p> <p>$\phi = 30^\circ$ $\gamma = 120 \text{ pcf} (19 \text{ kN/m}^3)$</p> <p>250 PSF (12 KPA) SURCHARGE</p> <p>H</p> <p>ZONE OF MULTISTACK</p> <p># FIRST COLUMN # SECOND COLUMN # THIRD COLUMN</p>	<p>H</p> <p>$\phi = 34^\circ$ $\gamma = 120 \text{ pcf} (19 \text{ kN/m}^3)$</p> <p>250 PSF (12 KPA) SURCHARGE</p> <p>H</p> <p>ZONE OF MULTISTACK</p> <p># FIRST COLUMN # SECOND COLUMN # THIRD COLUMN</p>
<p>4 Courses 2'-8" (800 mm)</p> <p>4-3-0</p>	<p>4 Courses 2'-8" (800 mm)</p> <p>4-2-0</p>	<p>4 Courses 2'-8" (800 mm)</p> <p>4-2-0</p>
<p>6 Courses 4'-0" (1200 mm)</p> <p>6-5-3</p>	<p>6 Courses 4'-0" (1200 mm)</p> <p>6-4-2</p>	<p>6 Courses 4'-0" (1200 mm)</p> <p>6-4-2</p>
<p>8 Courses 5'-4" (1600 mm)</p> <p>8-7-6</p>	<p>8 Courses 5'-4" (1600 mm)</p> <p>8-6-5</p>	<p>8 Courses 5'-4" (1600 mm)</p> <p>8-6-3</p>
<p>10 Courses 6'-8" (2000 mm)</p> <p>N/A</p>	<p>10 Courses 6'-8" (2000 mm)</p> <p>10-9-9</p>	<p>10 Courses 6'-8" (2000 mm)</p> <p>10-9-8</p>
<p>12 Courses 8'-0" (2400 mm)</p> <p>N/A</p>	<p>12 Courses 8'-0" (2400 mm)</p> <p>N/A</p>	<p>12 Courses 8'-0" (2400 mm)</p> <p>12-11-11</p>

Estimating Chart Structural Backfill Using AnchorPlex® System Diamond Pro® Retaining Walls 3:1 Crest Slope

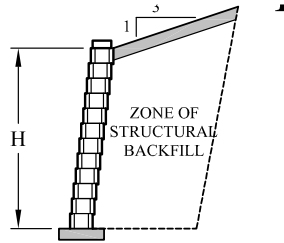

	Clay and Silt Soils $\phi = 26^\circ$ $\gamma = 120 \text{ pcf (19 kN/m}^3\text{)}$	Silty / Clayey Sand Soil $\phi = 30^\circ$ $\gamma = 120 \text{ pcf (19 kN/m}^3\text{)}$	Clean Sand and Gravel Soil $\phi = 34^\circ$ $\gamma = 120 \text{ pcf (19 kN/m}^3\text{)}$
4'-0" (1200 mm) 6 Courses	<p>2'-0" [600 mm]</p> <p>0.37 x Wall Length = CY of Structural Backfill</p>	<p>1'-0" [300 mm]</p> <p>0.22 x Wall Length = CY of Structural Backfill</p>	<p>1'-0" [300 mm]</p> <p>0.22 x Wall Length = CY of Structural Backfill</p>
6'-0" (1800 mm) 9 Courses	<p>3'-6" [1050 mm]</p> <p>0.89 x Wall Length = CY of Structural Backfill</p>	<p>1'-6" [450 mm]</p> <p>0.44 x Wall Length = CY of Structural Backfill</p>	<p>1'-0" [300 mm]</p> <p>0.33 x Wall Length = CY of Structural Backfill</p>
8'-0" (2400 mm) 12 Courses	<p>5'-6" [1650 mm]</p> <p>1.78 x Wall Length = CY of Structural Backfill</p>	<p>2'-6" [750 mm]</p> <p>0.89 x Wall Length = CY of Structural Backfill</p>	<p>1'-6" [450 mm]</p> <p>0.59 x Wall Length = CY of Structural Backfill</p>
10'-0" (3000 mm) 15 Courses	<p>Wall design to be performed by a professional engineer</p>	<p>3'-6" [1050 mm]</p> <p>1.48 x Wall Length = CY of Structural Backfill</p>	<p>2'-6" [750 mm]</p> <p>1.11 x Wall Length = CY of Structural Backfill</p>
12'-0" (3600 mm) 18 Courses	<p>Wall design to be performed by a professional engineer</p>	<p>4'-0" [1200 mm]</p> <p>2.00 x Wall Length = CY of Structural Backfill</p>	<p>3'-0" [900 mm]</p> <p>1.56 x Wall Length = CY of Structural Backfill</p>

Estimating Chart Structural Backfill Using AnchorPlex® System Diamond Pro® Retaining Walls No Slope / No Surcharges

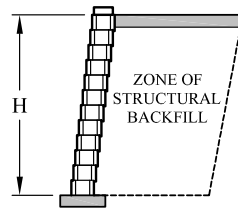

	Clay and Silt Soils $\phi = 26^\circ$ $\gamma = 120 \text{ pcf } (19 \text{ kN/m}^3)$	Silty / Clayey Sand Soil $\phi = 30^\circ$ $\gamma = 120 \text{ pcf } (19 \text{ kN/m}^3)$	Clean Sand and Gravel Soil $\phi = 34^\circ$ $\gamma = 120 \text{ pcf } (19 \text{ kN/m}^3)$
4'-0" (1200 mm) 6 Courses	<p style="text-align: center;">1'-0" [300 mm]</p> <p style="text-align: center;">0.22 x Wall Length = CY of Structural Backfill</p>	<p style="text-align: center;">1'-0" [300 mm]</p> <p style="text-align: center;">0.22 x Wall Length = CY of Structural Backfill</p>	<p style="text-align: center;">1'-0" [300 mm]</p> <p style="text-align: center;">0.22 x Wall Length = CY of Structural Backfill</p>
6'-0" (1800 mm) 9 Courses	<p style="text-align: center;">1'-6" [450 mm]</p> <p style="text-align: center;">0.44 x Wall Length = CY of Structural Backfill</p>	<p style="text-align: center;">1'-0" [300 mm]</p> <p style="text-align: center;">0.33 x Wall Length = CY of Structural Backfill</p>	<p style="text-align: center;">1'-0" [300 mm]</p> <p style="text-align: center;">0.33 x Wall Length = CY of Structural Backfill</p>
8'-0" (2400 mm) 12 Courses	<p style="text-align: center;">2'-6" [750 mm]</p> <p style="text-align: center;">0.89 x Wall Length = CY of Structural Backfill</p>	<p style="text-align: center;">1'-6" [450 mm]</p> <p style="text-align: center;">0.59 x Wall Length = CY of Structural Backfill</p>	<p style="text-align: center;">1'-6" [450 mm]</p> <p style="text-align: center;">0.59 x Wall Length = CY of Structural Backfill</p>
10'-0" (3000 mm) 15 Courses	<p style="text-align: center;">3'-0" [900 mm]</p> <p style="text-align: center;">1.30 x Wall Length = CY of Structural Backfill</p>	<p style="text-align: center;">2'-0" [600 mm]</p> <p style="text-align: center;">0.93 x Wall Length = CY of Structural Backfill</p>	<p style="text-align: center;">2'-6" [750 mm]</p> <p style="text-align: center;">1.11 x Wall Length = CY of Structural Backfill</p>
12'-0" (3600 mm) 18 Courses	<p style="text-align: center;">4'-0" [1200 mm]</p> <p style="text-align: center;">2.00 x Wall Length = CY of Structural Backfill</p>	<p style="text-align: center;">3'-0" [900 mm]</p> <p style="text-align: center;">1.56 x Wall Length = CY of Structural Backfill</p>	<p style="text-align: center;">3'-0" [900 mm]</p> <p style="text-align: center;">1.56 x Wall Length = CY of Structural Backfill</p>

Estimating Chart Structural Backfill Using AnchorPlex® System Diamond Pro® Retaining Walls 250 PSF Surcharge

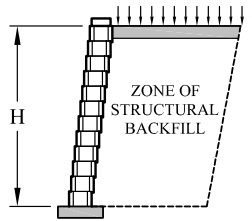

	Clay and Silt Soils $\phi = 26^\circ$ $\gamma = 120 \text{ pcf (19 kN/m}^3\text{)}$	Silty / Clayey Sand Soil $\phi = 30^\circ$ $\gamma = 120 \text{ pcf (19 kN/m}^3\text{)}$	Clean Sand and Gravel Soil $\phi = 34^\circ$ $\gamma = 120 \text{ pcf (19 kN/m}^3\text{)}$
4'-0" (1200 mm) 6 Courses	<p>2'-6" [750 mm]</p> <p>0.44 x Wall Length = CY of Structural Backfill</p>	<p>1'-6" [450 mm]</p> <p>0.30 x Wall Length = CY of Structural Backfill</p>	<p>1'-4" [400 mm]</p> <p>0.27 x Wall Length = CY of Structural Backfill</p>
6'-0" (1800 mm) 9 Courses	<p>3'-6" [1050 mm]</p> <p>0.89 x Wall Length = CY of Structural Backfill</p>	<p>2'-0" [600 mm]</p> <p>0.56 x Wall Length = CY of Structural Backfill</p>	<p>1'-0" [300 mm]</p> <p>0.22 x Wall Length = CY of Structural Backfill</p>
8'-0" (2400 mm) 12 Courses	<p>4'-0" [1200 mm]</p> <p>1.33 x Wall Length = CY of Structural Backfill</p>	<p>2'-6" [750 mm]</p> <p>0.89 x Wall Length = CY of Structural Backfill</p>	<p>1'-6" [450 mm]</p> <p>0.44 x Wall Length = CY of Structural Backfill</p>
10'-0" (3000 mm) 15 Courses	<p>Wall design to be performed by a professional engineer</p>	<p>3'-0" [900 mm]</p> <p>1.30 x Wall Length = CY of Structural Backfill</p>	<p>2'-6" [750 mm]</p> <p>1.11 x Wall Length = CY of Structural Backfill</p>
12'-0" (3600 mm) 18 Courses	<p>Wall design to be performed by a professional engineer</p>	<p>3'-6" [1050 mm]</p> <p>1.78 x Wall Length = CY of Structural Backfill</p>	<p>3'-0" [900 mm]</p> <p>1.56 x Wall Length = CY of Structural Backfill</p>

Estimating Chart Geosynthetic Belair Wall® Retaining Walls No Slopes / No Surcharges

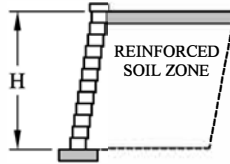

	Clay and Silt Soils $\phi = 26^\circ$ $\gamma = 120 \text{ pcf (19 kN/m}^3\text{)}$	Silty / Clayey Sand Soil $\phi = 30^\circ$ $\gamma = 120 \text{ pcf (19 kN/m}^3\text{)}$	Clean Sand and Gravel Soil $\phi = 34^\circ$ $\gamma = 120 \text{ pcf (19 kN/m}^3\text{)}$
2'-0" (600 mm) 4 Courses			
3'-0" (900 mm) 6 Courses			
4'-0" (1200 mm) 8 Courses			
5'-0" (1500 mm) 10 Courses			
6'-0" (1800 mm) 12 Courses			

Estimating Chart Geosynthetic Belair Wall® Retaining Walls 250 PSF Surcharge

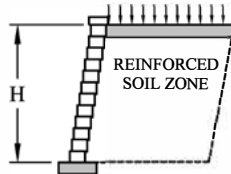

	Clay and Silt Soils $\phi = 26^\circ$ $\gamma = 120 \text{ pcf (19 kN/m}^3\text{)}$	Silty / Clayey Sand Soil $\phi = 30^\circ$ $\gamma = 120 \text{ pcf (19 kN/m}^3\text{)}$	Clean Sand and Gravel Soil $\phi = 34^\circ$ $\gamma = 120 \text{ pcf (19 kN/m}^3\text{)}$
2'-0" (600 mm) 4 Courses			 NO REINFORCEMENT REQUIRED
3'-0" (900 mm) 6 Courses			
4'-0" (1200 mm) 8 Courses			
5'-0" (1500 mm) 10 Courses			
6'-0" (1800 mm) 12 Courses			

Estimating Chart Geosynthetic Belair Wall® Retaining Walls 3:1 Crest Slope

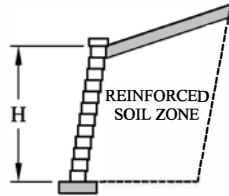

	Clay and Silt Soils $\phi = 26^\circ$ $\gamma = 120 \text{ pcf (19 kN/m}^3\text{)}$	Silty / Clayey Sand Soil $\phi = 30^\circ$ $\gamma = 120 \text{ pcf (19 kN/m}^3\text{)}$	Clean Sand and Gravel Soil $\phi = 34^\circ$ $\gamma = 120 \text{ pcf (19 kN/m}^3\text{)}$
2'-0" (600 mm) 4 Courses			
3'-0" (900 mm) 6 Courses			
4'-0" (1200 mm) 8 Courses			
5'-0" (1500 mm) 10 Courses			
6'-0" (1800 mm) 12 Courses			

Estimating Chart Structural Backfill Using AnchorPlex® System

Belair Wall® Retaining Walls

No Slope / No Surcharge

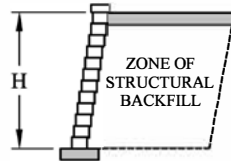





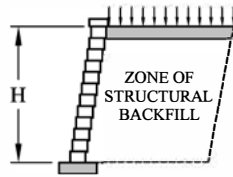

	Clay and Silt Soils $\phi = 26^\circ$ $\gamma = 120 \text{ pcf (19 kN/m}^3\text{)}$	Silty / Clayey Sand Soil $\phi = 30^\circ$ $\gamma = 120 \text{ pcf (19 kN/m}^3\text{)}$	Clean Sand and Gravel Soil $\phi = 34^\circ$ $\gamma = 120 \text{ pcf (19 kN/m}^3\text{)}$
2'-0" (600 mm) 4 Courses	<p>1'-0" [300 mm]</p> <p>0.08 x Wall Length = CY of Structural Backfill</p>	<p>1'-0" [300 mm]</p> <p>0.12 x Wall Length = CY of Structural Backfill</p>	<p>1'-0" [300 mm]</p> <p>0.16 x Wall Length = CY of Structural Backfill</p>
3'-0" (900 mm) 6 Courses	<p>1'-0" [300 mm]</p> <p>0.12 x Wall Length = CY of Structural Backfill</p>	<p>1'-0" [300 mm]</p> <p>0.16 x Wall Length = CY of Structural Backfill</p>	<p>1'-0" [300 mm]</p> <p>0.29 x Wall Length = CY of Structural Backfill</p>
4'-0" (1200 mm) 8 Courses	<p>1'-0" [300 mm]</p> <p>0.16 x Wall Length = CY of Structural Backfill</p>	<p>1'-0" [300 mm]</p> <p>0.29 x Wall Length = CY of Structural Backfill</p>	<p>1'-6" [450 mm]</p> <p>0.29 x Wall Length = CY of Structural Backfill</p>
5'-0" (1500 mm) 10 Courses	<p>1'-6" [450 mm]</p> <p>0.29 x Wall Length = CY of Structural Backfill</p>	<p>1'-6" [450 mm]</p> <p>0.35 x Wall Length = CY of Structural Backfill</p>	<p>1'-6" [450 mm]</p> <p>0.35 x Wall Length = CY of Structural Backfill</p>
6'-0" (1800 mm) 12 Courses	<p>1'-6" [450 mm]</p> <p>0.35 x Wall Length = CY of Structural Backfill</p>	<p>1'-6" [450 mm]</p> <p>0.35 x Wall Length = CY of Structural Backfill</p>	<p>1'-6" [450 mm]</p> <p>0.35 x Wall Length = CY of Structural Backfill</p>

Estimating Chart Structural Backfill Using AnchorPlex® System

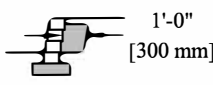
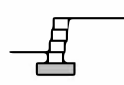
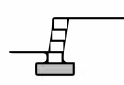
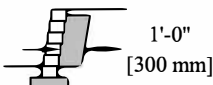
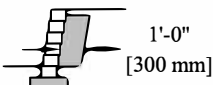
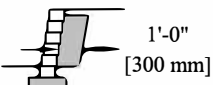
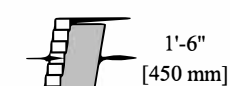
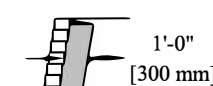
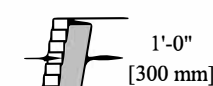
Belair Wall® Retaining Walls

250 PSF Surcharge



	Clay and Silt Soils $\phi = 26^\circ$ $\gamma = 120 \text{ pcf (19 kN/m}^3\text{)}$	Silty / Clayey Sand Soil $\phi = 30^\circ$ $\gamma = 120 \text{ pcf (19 kN/m}^3\text{)}$	Clean Sand and Gravel Soil $\phi = 34^\circ$ $\gamma = 120 \text{ pcf (19 kN/m}^3\text{)}$
2'-0" (600 mm) 4 Courses	 <p>1'-0" [300 mm]</p> <p>0.08 x Wall Length = CY of Structural Backfill</p>		
3'-0" (900 mm) 6 Courses	 <p>1'-0" [300 mm]</p> <p>0.12 x Wall Length = CY of Structural Backfill</p>	 <p>1'-0" [300 mm]</p> <p>0.12 x Wall Length = CY of Structural Backfill</p>	 <p>1'-0" [300 mm]</p> <p>0.12 x Wall Length = CY of Structural Backfill</p>
4'-0" (1200 mm) 8 Courses	 <p>1'-6" [450 mm]</p> <p>0.24 x Wall Length = CY of Structural Backfill</p>	 <p>1'-0" [300 mm]</p> <p>0.16 x Wall Length = CY of Structural Backfill</p>	 <p>1'-0" [300 mm]</p> <p>0.16 x Wall Length = CY of Structural Backfill</p>
5'-0" (1500 mm) 10 Courses	 <p>2'-0" [600 mm]</p> <p>0.39 x Wall Length = CY of Structural Backfill</p>	 <p>1'-6" [450 mm]</p> <p>0.29 x Wall Length = CY of Structural Backfill</p>	 <p>1'-6" [450 mm]</p> <p>0.29 x Wall Length = CY of Structural Backfill</p>
6'-0" (1800 mm) 12 Courses	 <p>2'-0" [600 mm]</p> <p>0.46 x Wall Length = CY of Structural Backfill</p>	 <p>1'-6" [450 mm]</p> <p>0.35 x Wall Length = CY of Structural Backfill</p>	 <p>1'-6" [450 mm]</p> <p>0.35 x Wall Length = CY of Structural Backfill</p>

Estimating Chart Structural Backfill Using AnchorPlex® System

Belair Wall® Retaining Walls

3:1 Crest Slope

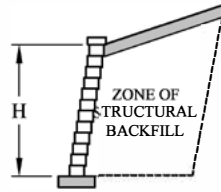

	Clay and Silt Soils $\phi = 26^\circ$ $\gamma = 120 \text{ pcf (19 kN/m}^3\text{)}$	Silty / Clayey Sand Soil $\phi = 30^\circ$ $\gamma = 120 \text{ pcf (19 kN/m}^3\text{)}$	Clean Sand and Gravel Soil $\phi = 34^\circ$ $\gamma = 120 \text{ pcf (19 kN/m}^3\text{)}$
2'-0" (600 mm) 4 Courses	<p>1'-0" [300 mm]</p> <p>0.08 x Wall Length = CY of Structural Backfill</p>	<p>1'-0" [300 mm]</p> <p>0.12 x Wall Length = CY of Structural Backfill</p>	<p>1'-0" [300 mm]</p> <p>0.12 x Wall Length = CY of Structural Backfill</p>
3'-0" (900 mm) 6 Courses	<p>1'-6" [450 mm]</p> <p>0.18 x Wall Length = CY of Structural Backfill</p>	<p>1'-0" [300 mm]</p> <p>0.12 x Wall Length = CY of Structural Backfill</p>	<p>1'-0" [300 mm]</p> <p>0.12 x Wall Length = CY of Structural Backfill</p>
4'-0" (1200 mm) 8 Courses	<p>2'-0" [600 mm]</p> <p>0.31 x Wall Length = CY of Structural Backfill</p>	<p>1'-0" [300 mm]</p> <p>0.16 x Wall Length = CY of Structural Backfill</p>	<p>1'-0" [300 mm]</p> <p>0.16 x Wall Length = CY of Structural Backfill</p>
5'-0" (1500 mm) 10 Courses	<p>2'-6" [750 mm]</p> <p>0.48 x Wall Length = CY of Structural Backfill</p>	<p>2'-0" [600 mm]</p> <p>0.39 x Wall Length = CY of Structural Backfill</p>	<p>1'-6" [450 mm]</p> <p>0.29 x Wall Length = CY of Structural Backfill</p>
6'-0" (1800 mm) 12 Courses	<p>3'-0" [900 mm]</p> <p>0.69 x Wall Length = CY of Structural Backfill</p>	<p>2'-0" [600 mm]</p> <p>0.46 x Wall Length = CY of Structural Backfill</p>	<p>1'-6" [450 mm]</p> <p>0.35 x Wall Length = CY of Structural Backfill</p>

FIRE FEATURES



FIRE FEATURES INSTALLATION GUIDE

148 Installation Instructions

FIRE FEATURES

149 Bordeaux™ Series

152 Dublin Fireplace

153 Melville™ Series

156 Flagstone Fire Pit Kit

157 Weston Stone™ Fire Pit Kit

STANDARD INSTALLATION INSTRUCTIONS

GRAVEL BASE

Gravel Fill shall be a clean angular stone or angular granular fill meeting the following gradation as determined in accordance with ASTM D 422.

<u>Sieve Size</u>	<u>Percent Passing</u>
1-in	100
3/4-in	75-100
No. 4	0-60
No. 40	0-50
No. 200	0-12

FOUNDATION PREPARATION

Following excavation of the leveling pad, foundation soil shall be examined to assure the actual foundation soil strength meets or exceeds the assumed design bearing strength. Soils not meeting the required strength shall be removed and replaced with soil meeting the design criteria.



*Scan for Fortified Installation Method
to be used with soft soils or expanding clays*

LEVELING PAD PREPARATION

A minimum 18-in thick layer or compacted granular material shall be placed for use as a leveling pad up to the grades and locations as shown on the construction drawings. The granular base shall be compacted to a firm, level bearing pad on which to place the bottom level of the unit. A leveling pad consisting of 6-in (minimum) thick lean, unreinforced concrete may be used at the contractor's option, or if so detailed on the plans. The leveling pad should extend a minimum of 6-in from the toe and from the heel of the unit base.

GRAVEL FILL

Gravel fill shall be placed to the minimum finished thickness and width shown on the construction plans.

Gravel lifts shall be a maximum thickness of 6-in.

Lifts shall be compacted by three passes of a light weight vibratory plate compactor.

For areas not affected by freeze-thaw conditions please contact your local Belgard sales representative for further installation information.

BORDEAUX™ SERIES

NATURAL
COLLECTION 



Scan for additional
product information

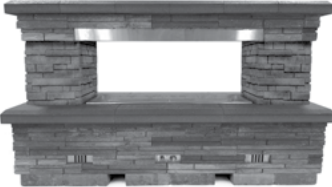

BORDEAUX™ SERIES

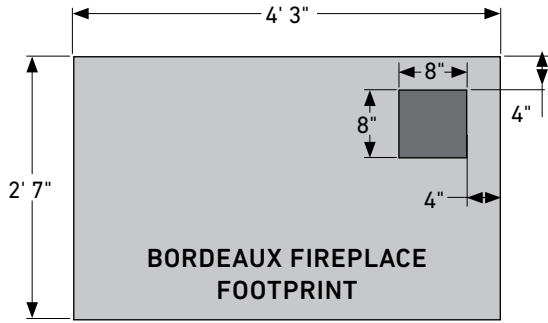

FIREPLACE

Rough Dimensions:
2'7\"/>

Approximate Weight:
4200 lbs.

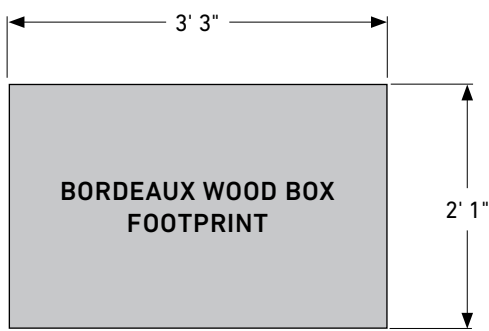
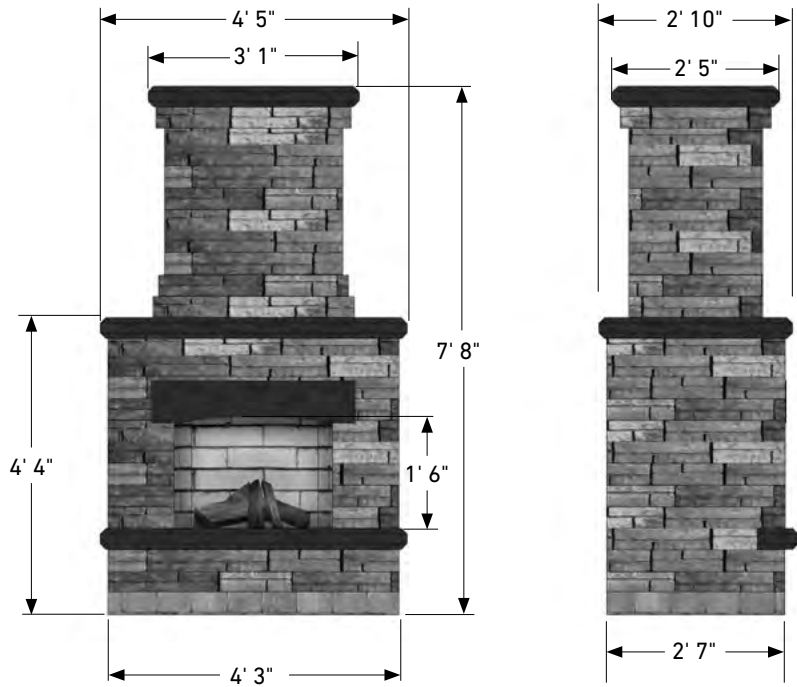

WOOD BOXES

Rough Dimensions:
2'1\"/>

Approximate Weight:
3070 lbs.

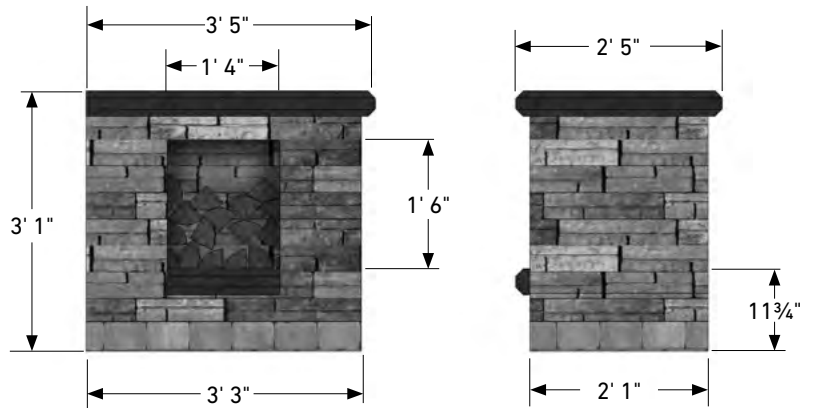

GRILL ISLAND

Rough Dimensions:
2'8\"/>

Approximate Weight:
2500 lbs.

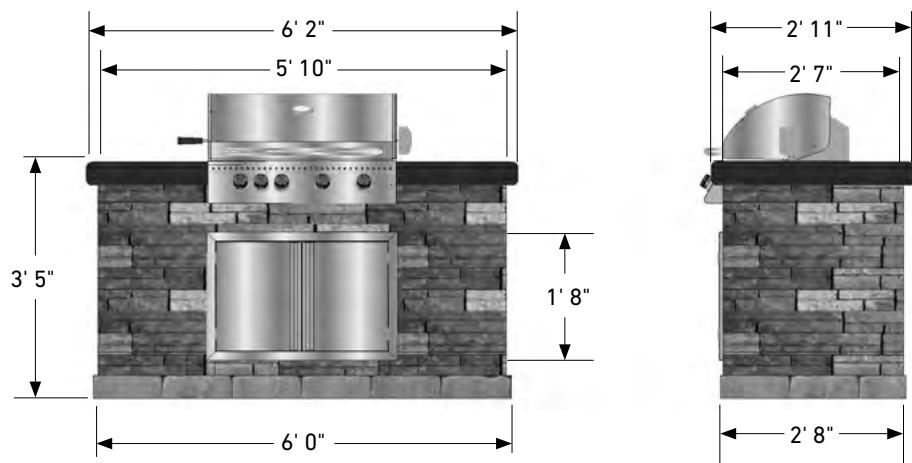

BORDEAUX™ SERIES

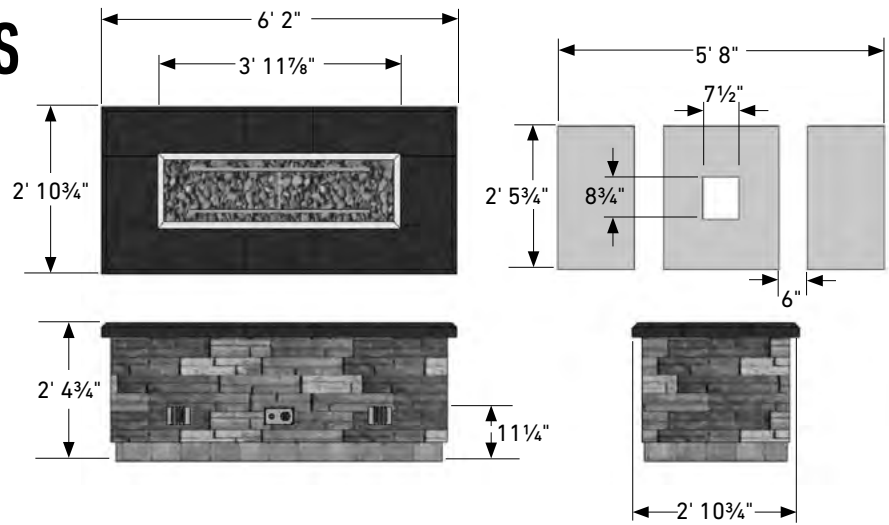

LINEAR FIRE TABLE

Rough Dimensions:
2'10³/₄" D x 6'2" W x 2'4³/₄" H

Approximate Weight:
2500 lbs.

LINEAR FIREPLACE

Rough Dimensions:
2'6"D x 7'1"W x 5'4"H

Approximate Weight:
3700 lbs.

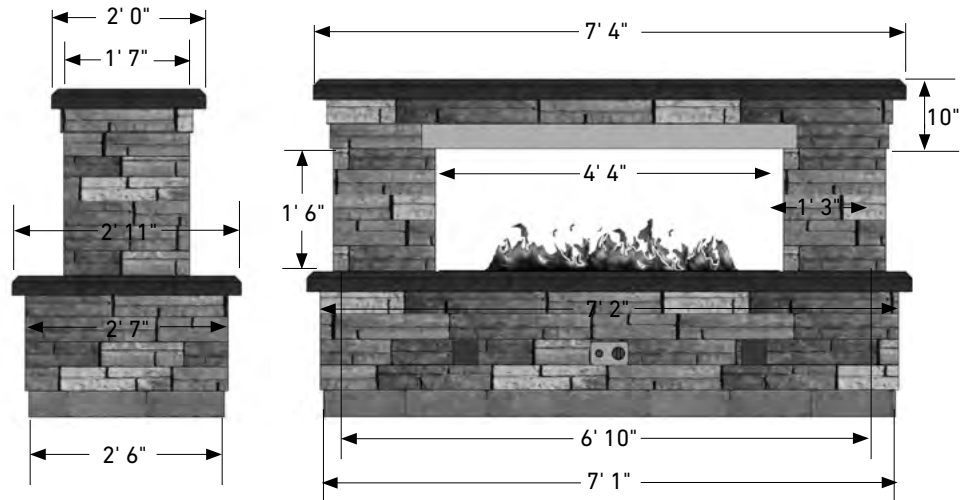

36" wood burning fireplace can be converted to a vented gas unit on-site.

DUBLIN FIREPLACE KIT

HERITAGE
COLLECTION 



BEFORE YOU GET STARTED:

- Have a tape measure handy at all times.
- Lay block left-to-right or back-to-front instead of outside-to-in. Laying block outside to in will make it difficult to place the inner blocks.
- When unloading the pallet, place the removed block at two to three feet from the pallet, leaving a clear path on all sides of the pallet. This will ensure easy access to the pallet at all times. And if you want to make it extra easy on yourself, group alike blocks together for quick reference — A's together, B's together, etc.
- Be gentle with the CopingStone. It's delicate and may break if handled too roughly.
- Make sure the letters on each block face a connecting block so they are hidden.
- Once each course has been placed, make sure you tighten it up by using a rubber mallet on the edges.

INCLUDED IN YOUR FIREPLACE OR WOODBOX

- All Block, Coping, Lintel, Firebrick and Caps that are needed for completion
- Detailed, easy to follow, step-by-step manual with diagrams
- Two tubes of adhesive for Coping and Firebrick

This fireplace is designed to burn solid wood, plumbed propane or natural gas only. Gas log appliances must be approved for outdoor use. Please obtain the proper permits in your local jurisdiction and make sure to comply with all building codes. This fireplace is not designed to be used indoors or in any framed wooden structure. It should not be placed next to or on any combustible materials. Do not fill voids with insulation or any other materials. This fireplace is not intended to be used for cooking food. Belgard recommends using a grate centered in Burning Box for optimum burning performance. Do not stack wood against block walls while burning. Be aware that sparks can escape and ignite combustible surroundings. Do not over pack with wood.

FIREPLACE KIT

Rough Dimensions:
4' 3"D x 5'W x 8' 6"H

WOOD BOX

Rough Dimensions:
3' 3"D x 3' 6"W x 3' 5"H

MELVILLE™ SERIES

METROPOLITAN
COLLECTION 



*Scan for additional
product information*



MELVILLE™ SERIES

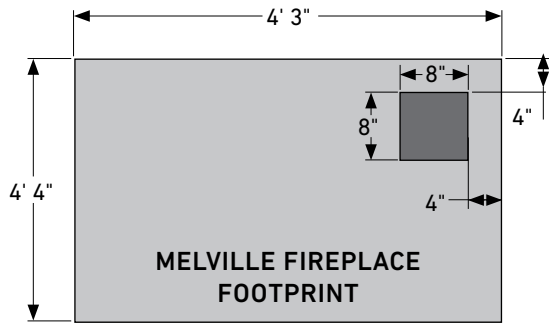

FIREPLACE

Rough Dimensions:
2' 7" D x 4' 3" W x 7' 8" H

Approximate Weight:
4205 lbs.

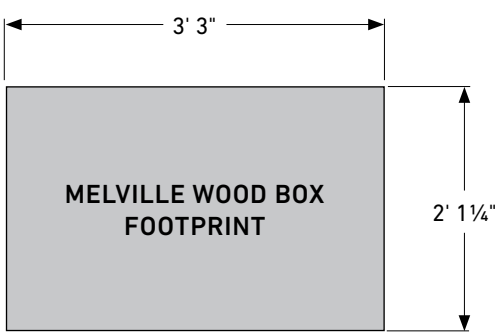
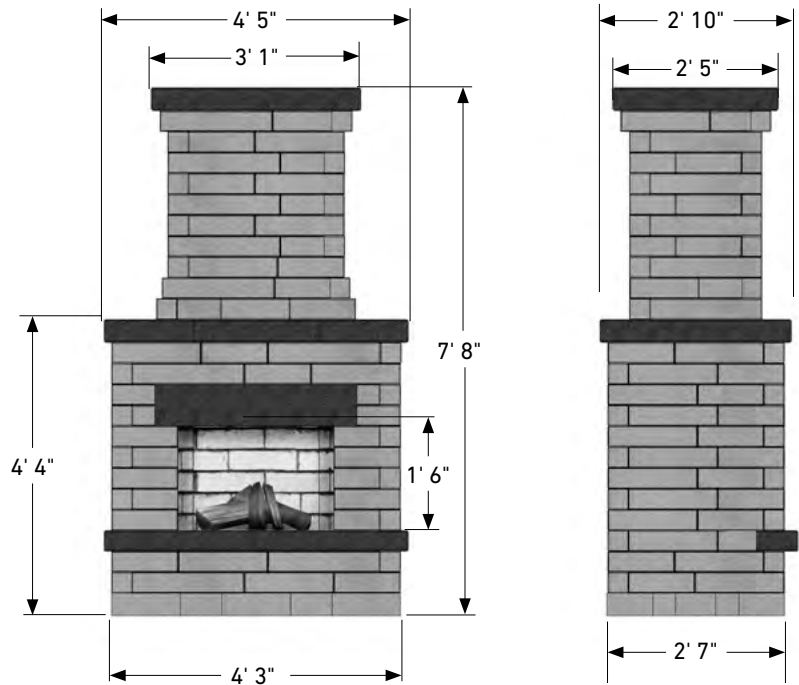

WOOD BOXES

Rough Dimensions:
2' 1" D x 3' 3" W x 3' 1" H

Approximate Weight:
3070 lbs. or 1535 lbs. each

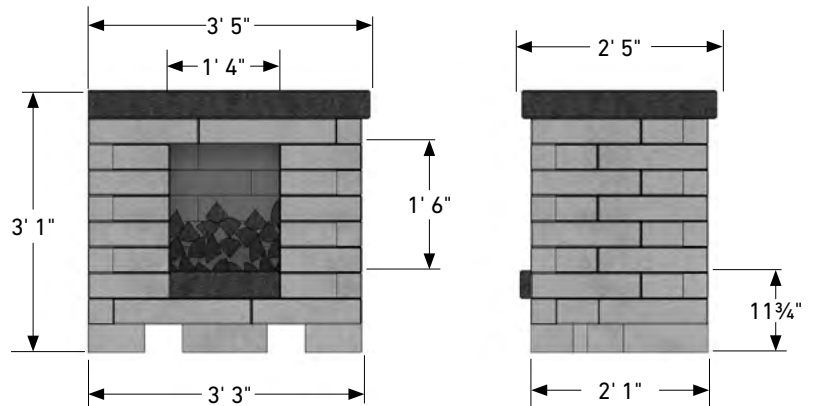

GRILL ISLAND

Rough Dimensions:
2' 8" D x 5' 11" W x 3' 5" H

Approximate Weight:
3500 lbs.

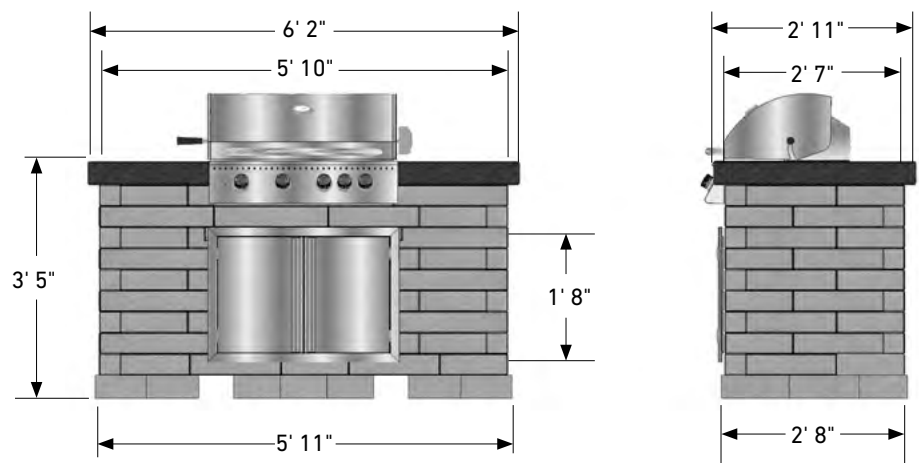

MELVILLE™ SERIES

LINEAR FIRE TABLE

Rough Dimensions:
2' 6" D x 5' 8" W x 2' 5" H
Approximate Weight:
2500 lbs.

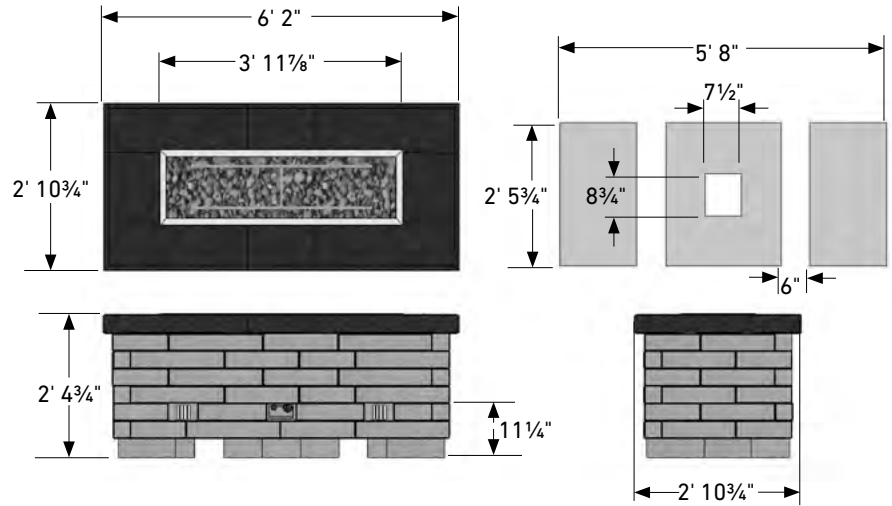

LINEAR FIREPLACE

Rough Dimensions:
2' 6" D x 7' 1" W x 5' 4" H
Approximate Weight:
4000 lbs.

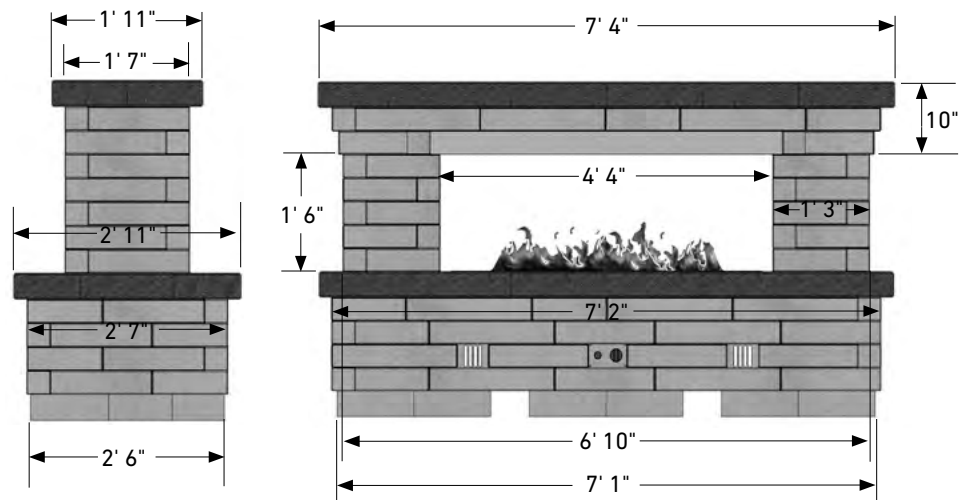

FLAGSTONE FIRE PIT



Scan for additional
product information

RESIDENTIAL	COMMERCIAL	STEPS	COLUMNS	FIRE PITS	KITCHEN	FREESTANDING WALL	RETAINING WALL
✓				✓			

SHAPES & SIZES

Kit



UNIT	HEIGHT	OUTSIDE DIAMETER	RING INCLUDED	WEIGHT/ PALLET
FIRE PIT KIT				
FIRE PIT KIT	12	APPROX. 44"	YES	860 W/ INSERT

WESTON STONE™ FIRE PIT

HERITAGE
COLLECTION **H**



Scan for additional
product information

RESIDENTIAL	COMMERCIAL	STEPS	COLUMNS	FIRE PITS	KITCHEN	FREESTANDING WALL	RETAINING WALL
✓				✓			

SHAPES & SIZES

Kit



UNIT	HEIGHT	OUTSIDE DIAMETER	INSIDE DIAMETER	RING INCLUDED	WEIGHT/PALLET
------	--------	------------------	-----------------	---------------	---------------

FIRE PIT KIT

FIRE PIT KIT	16	APPROX. 55"	APPROX. 39"	YES	1525 W/ INSERT
--------------	----	-------------	-------------	-----	-------------------

FIRE PIT KITS INSTALLATION INSTRUCTIONS

- Always use in accordance with all applicable local and state fire codes
- Failure to follow these instructions could result in a hazardous fire causing property damage or physical injury
- Caution: For outdoor use only
- Use the fire ring on stone, dirt or sand surfaces
- For adult use only — do not allow children to use the fire ring
- Do not use on lawns, wooden decks, concrete or asphalt
- Do not use fire ring indoors or under a patio roof
- Do not use in windy conditions
- Do not leave fire unattended at any time
- Do not use under tree branches, trellis, or overhangs of any kind, including covered porches
- Do not use flammable liquids such as gasoline, alcohol, diesel fuel, kerosene, or charcoal lighter fluid to light or relight fires as this may also cause paint to flake off fire ring
- Care should be taken to make sure all combustible material is far enough away from the fire ring not to ignite it
- Avoid using softwoods such as pine or cedar because they are likely to throw sparks — hardwoods are recommended
- Keep children and pets away from the fire ring while it is in use
- Exercise the same precautions you would with any open fire
- Do not wear flammable or loose clothing when tending an open fire
- Avoid touching surfaces as they will be extremely hot
- Assure the fire is completely extinguished before leaving fire ring
- Any modifications to this appliance may be dangerous and are not permitted

ADDITIONAL MATERIALS NEEDED

- Tamper
- Level
- 2 Bags of Leveling Sand
- 2 Tubes of Concrete Adhesive
- Caulk Gun
- 3 Bags of Gravel or Lava Rock
- Shovel
- Optional Marking Paint or Chalk





CUSTOMIZE YOUR SPACE

ACCESSORIES

- 160 Anglia Edger®
- 162 Artforms™
- 164 Eastwood Coping
- 165 Landings™ Step
- 168 Melville™ Curb
- 169 U Start Base Block®



Scan for additional
product information

RESIDENTIAL	COMMERCIAL	STEPS	CAPS	COPING
				
✓	✓			

SHAPES & SIZES

Edger Units

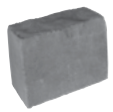

8 x 7⁷/₈ x 4¹/₂

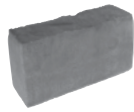

8 x 10¹/₂ x 4¹/₂



8 x 15¹/₂ x 4¹/₂

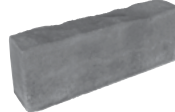

8 x 17⁷/₈ x 4¹/₂

UNIT	LNFT/ PALLET	LNFT/ LAYER	LAYER/ PALLET	UNITS/ PALLET	UNITS/ LAYER	UNITS/ LNFT	WEIGHT/ PALLET
------	-----------------	----------------	------------------	------------------	-----------------	----------------	-------------------

EDGER UNITS





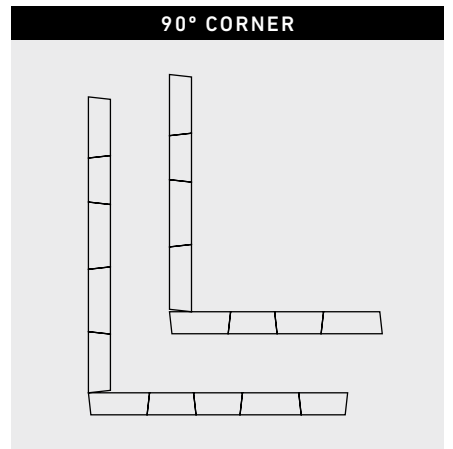
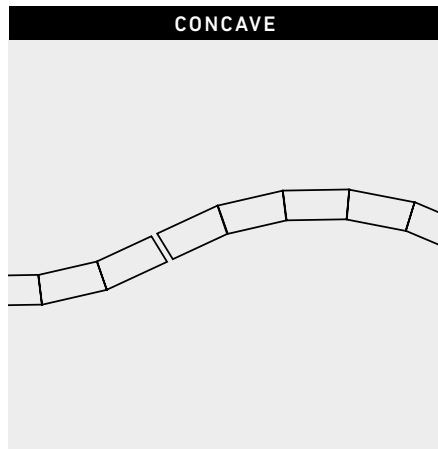
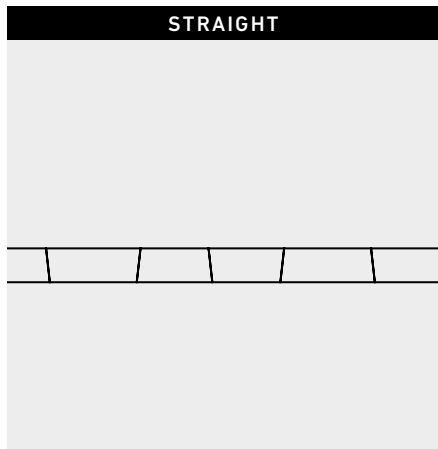
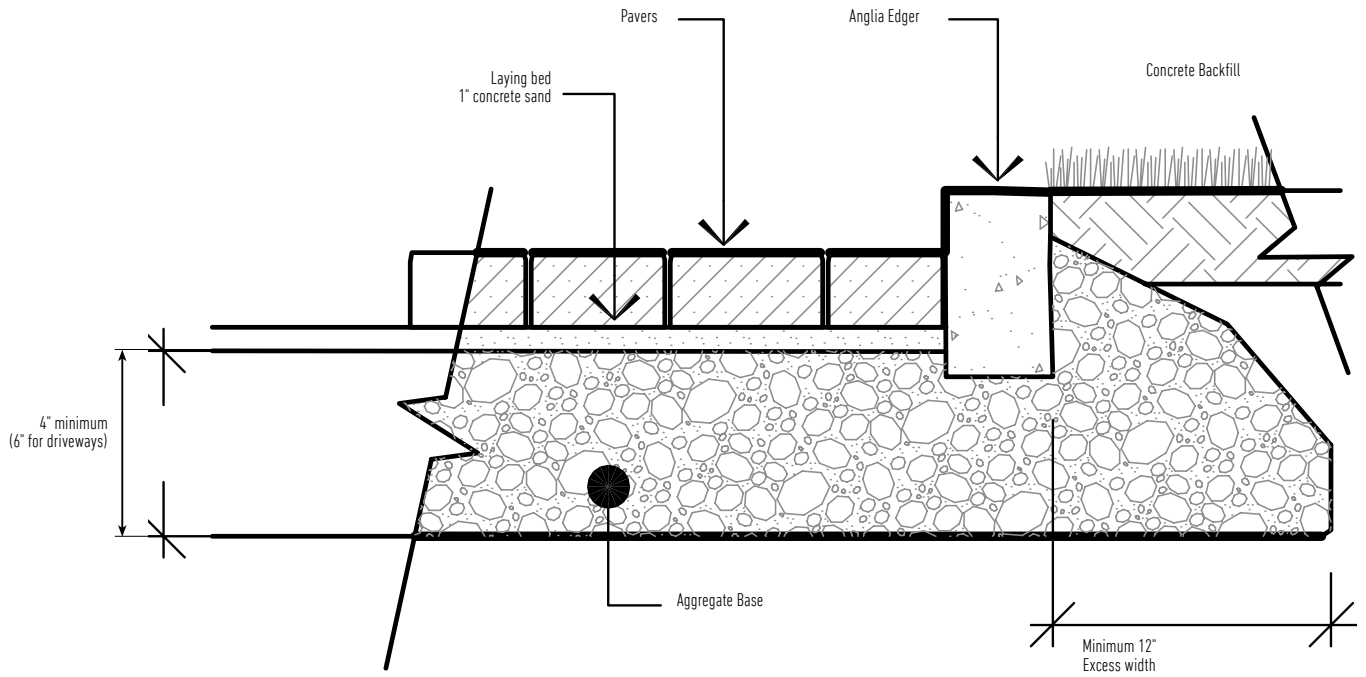



8 X 7 ⁷ / ₈ X 4 ¹ / ₂	7.5	2.5	–	12	4	1.6	–
8 X 10 ¹ / ₂ X 4 ¹ / ₂	9.996	3.332	–	12	4	1.2	–
8 X 15 ¹ / ₂ X 4 ¹ / ₂	15.504	5.168	–	12	4	0.774	–
8 X 17 ⁷ / ₈ X 4 ¹ / ₂	34.992	11.664	–	24	8	0.686	–
TOTAL	69.75	22.667	3	60	–	–	2515

ANGLIA EDGER INSTALLATION INSTRUCTIONS





Scan for additional product information

RESIDENTIAL	COMMERCIAL	STEPS	CAPS	FIRE PITS	KITCHEN	FREESTANDING WALL	RETAINING WALL
							
✓	✓		✓	✓	✓		

SHAPES & SIZES

18 x 36*

6 x 36*

Installation Hardware



18 x 36 x 3

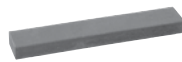

6 x 36 x 3

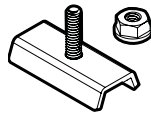

Anchor Slide & Nut

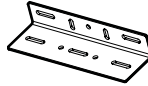

Joining Plate

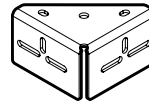

Outer Corner

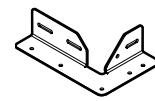

Inner Corner

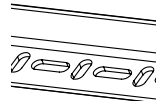

Stretcher

*Pallets contain both open and closed ended units

UNIT	SQFT/PALLET	SQFT/LAYER	LAYER/PALLET	UNITS/PALLET	UNITS/LAYER	UNITS/SQFT	WEIGHT/PALLET
------	-------------	------------	--------------	--------------	-------------	------------	---------------

COPING UNIT

18 X 36 X 3	81	9	9	18*	2	-	2754**
6 X 36 X 3	31.5	10.5	3	21*	7	-	1095

*Total number of both open and closed end panels. 18 x 36 pallets contain 9 of each. 6 x 36 pallets contain 3 open end panels and 18 closed end panels

**150lbs is the weight for the closed units, 148lbs is the weight for the open units.

18 X 36 X 3'

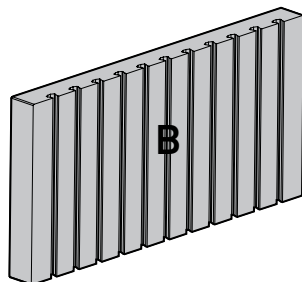
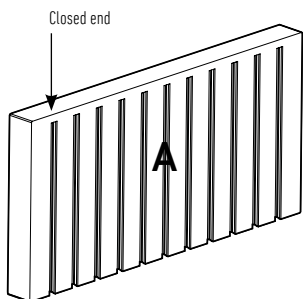

6 X 36 X 3'

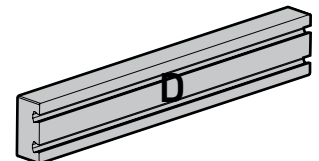
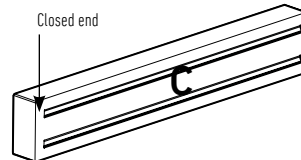

PANEL CONFIGURATIONS

IDEAL:

This configuration uses equal number of panel A and panel B.

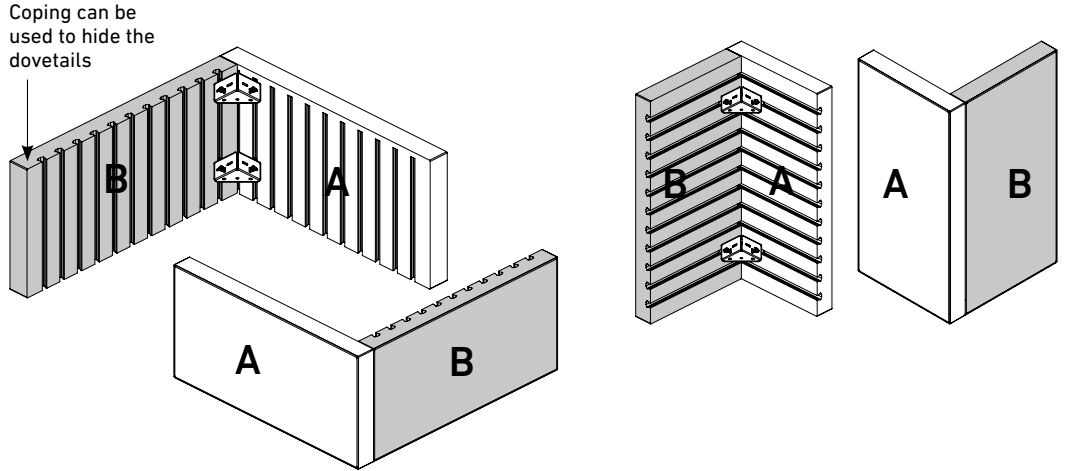

NOT OPTIMAL:

This configuration uses panel A only.

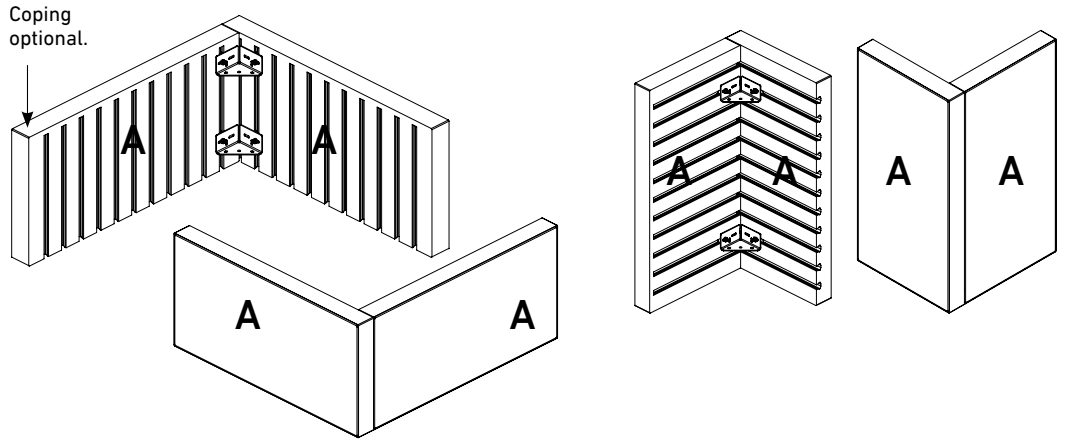

NOT RECOMMENDED:

This configuration uses panel B only and the dovetails are exposed. Use ideal configuration as shown above.

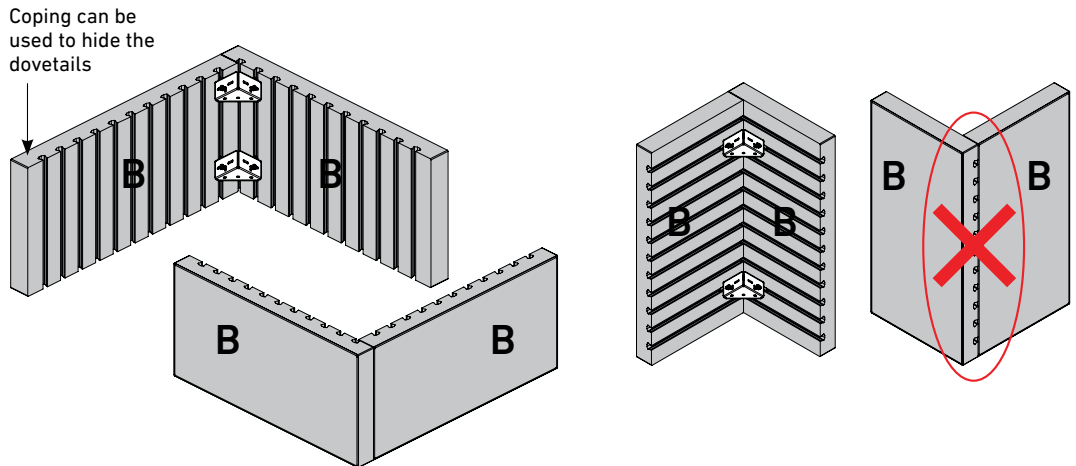





*IMPORTANT: When planning configurations, consider the amount of panel A and panel B on a pallet. 18 x 36" panels are sold in pair/layer or in full pallet only. 6 x 36" panels are sold in layer or in full pallet only.

EASTWOOD COPING



Scan for additional product information

RESIDENTIAL	COMMERCIAL	STEPS	CAPS	COPING
				
✓	✓	✓		✓

SHAPES & SIZES

Coping



6 x 12 x 2³/₈





UNIT	LNFT/ PALLET	LNFT/ LAYER	LAYER/ PALLET	UNITS/ PALLET	UNITS/ LAYER	WEIGHT/ PALLET
COPING						
6 X 12 X 2 ³ / ₈	84	21	4	168	42	2520

LANDINGS™ STEP

NATURAL
COLLECTION 



Scan for additional
product information

RESIDENTIAL	COMMERCIAL	STEPS	CAPS	COPING
				
✓	✓	✓		

SHAPES & SIZES

Step Unit



6 x 48 x 18

UNIT	SQFT/ PALLET	SQFT/ LAYER	LAYER/ PALLET	UNITS/ PALLET	UNITS/ LAYER	WEIGHT/ UNIT	WEIGHT/ PALLET
STEP UNIT							
6 X 48 X 18	-	-	-	6	-	460	2760



LANDINGS™ STEP UNIT INSTALLATION

Each Landings™ Step Unit is manufactured with two unique face patterns. The step units are palletized and packaged for easy skid-steer loader removal. Care needs to be taken in handling these units. If a blemish occurs on one side of unit, rotate 180° before setting unit into place.

BASE COURSE

Excavate an area 6 inches deep by 1 foot longer by 1 foot wider than the installed step(s) size. Add a minimum of 6 inches of compactable base material, 3/4-inch minus (with fines) aggregate. Compact and level. Set unit and, if desired, add a slight pitch of no more than 1/4 inch toward the front of the step to shed moisture. If installing step units next to a retaining wall, keep units level from front to back.

The Textures on Sides 1 and 2 are Designed to Nest with Minimal Gapping Between the Units.

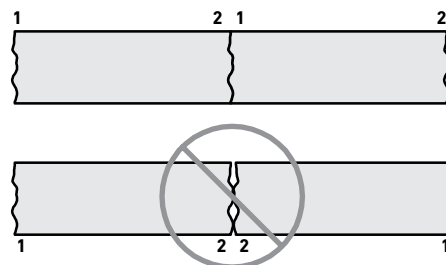

Place Units so They Nest Tightly Together.



Two unique faces on each step

STAIR TREAD

For each consecutive step, follow base course instructions, making sure the top of the base is even with the top of the previously installed unit. Recommended tread depth is a minimum of 10 inches, but no more than 16 inches. When installing steps adjacent to a finished surface such as pavers, as illustrated, a 6-inch-tall dummy block needs to be installed below the first step.

LANDING

For landing(s) follow base course instructions. Each step unit is manufactured with two unique face patterns. The face patterns are manufactured to nest together, which will create a narrower joint, providing pleasing aesthetics.

STEPS IN A 90-DEGREE WALL

When building into a retaining wall, construct the steps first and build the walls adjacent to the steps.

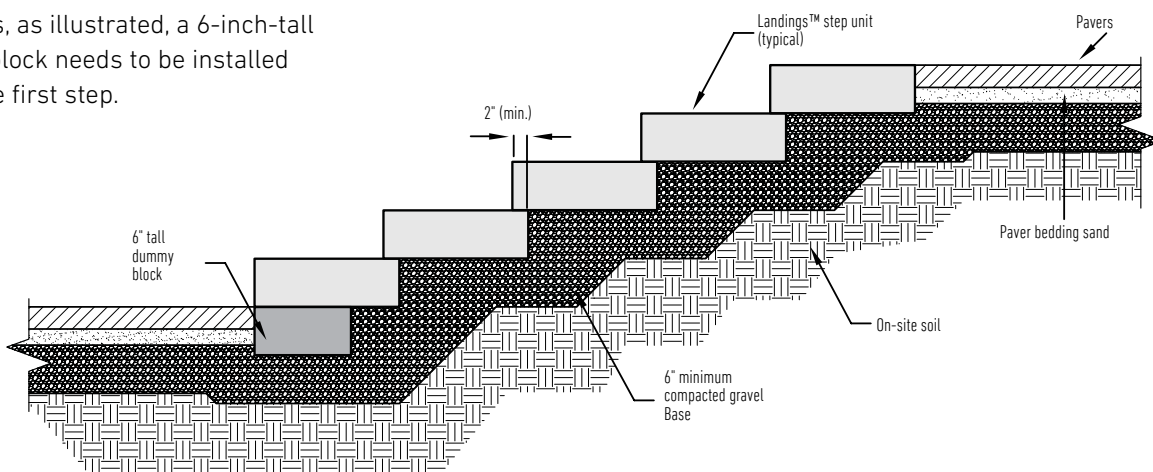

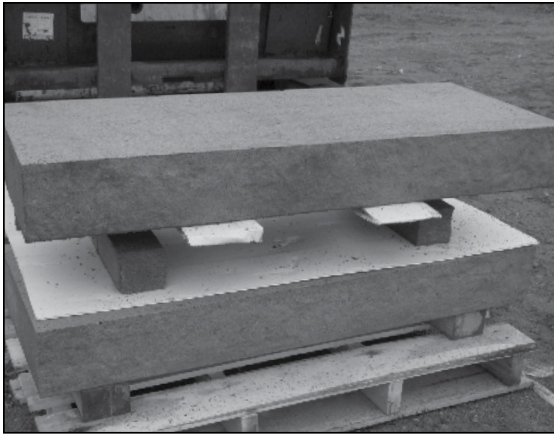

SKID-STEER LOADER

Slide forks underneath the first step unit and lift off pallet. Set the step unit onto its desired location, using a spacer to ease in fork removal.



A helpful tip to protect the step unit is to wrap the fork of the skid-steer with corrugated plastic packaging from the pallet or other protective materials. Secure to the forks.

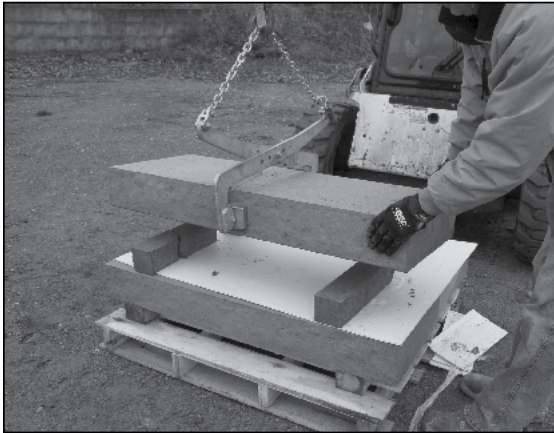

CLAMP

Using a materials clamp, center the clamp on the step unit. Attach clamp to skid-steer or mini-excavator and slowly lift the step unit off of the pallet and move it into place. Be sure to have a second person to help guide the unit into place as the machine sets the step unit down.



STRAPS

When using a heavy duty strap(s), start by wrapping the strap(s) around the center if using one or close to step unit ends if two straps are being used. Cinch the strap(s) tight and attach the looped ends of the strap(s) to skid-steer or mini-excavator. Slowly lift the step unit from the pallet and move it into place. Be sure to have a second person to help guide the unit into place as the machine sets the step unit down. Using a spacer will help to ease in the strap removal.







CART

When using a cart, place provided corrugated plastic from pallet or other protective material onto the cart to help protect the step unit. With help from a second person, slowly slide the step unit from the pallet onto the cart. Maneuver the unit carefully into place.

Videos can be found on our YouTube channel:
www.youtube.com/anchorblockmn



Scan for additional
product information

RESIDENTIAL	COMMERCIAL	STEPS	CAPS	COPING
				
✓	✓			

SHAPES & SIZES

Curb Unit

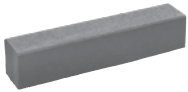

4 x 24 x 6½

UNIT	LNFT/ PALLET	LNFT/ LAYER	LAYER/ PALLET	UNITS/ PALLET	UNITS/ LAYER	UNITS/ LNFT	WEIGHT/ PALLET
CURB UNIT							
4 X 24 X 6½	96	24	4	48	12	0.5	2600

U START BASE BLOCK®



Scan for additional product information

RESIDENTIAL	COMMERCIAL	STEPS	CAPS	COPING
✓	✓			

See wall installation instructions on page [XXXXXX](#)

SHAPES & SIZES

Unit



12 x 16½ x 3½

UNIT	LNFT/ PALLET	LNFT/ LAYER	LAYER/ PALLET	UNITS/ PALLET	UNITS/ LAYER	WEIGHT/ PALLET
UNIT						
12 X 16½ X 3½	77	11	7	56	8	2870

BELGARD® | PAVES THE WAY®

LOCATIONS

GREENSBORO

108 Buchanan Church Rd
Greensboro, NC 27405

COWPENS

165 Allison Rd
Cowpens, SC 29330

RIDGEWAY

355 Commerce Blvd
Ridgeway, SC 29130

HOLLY HILL

560 Park Circle
Holly Hill, SC 29059

HARDSCAPES SALES & RESOURCE CENTER

625 Griffith Rd, Suite 115
Charlotte, NC 28217
800-545-5080

STAY CONNECTED WITH BELGARD.



[Pinterest.com/Belgard](https://www.pinterest.com/Belgard)



[Facebook.com/OutdoorLivingbyBelgard](https://www.facebook.com/OutdoorLivingbyBelgard)



[Belgard.com/Blog](https://belgard.com/blog)



[YouTube.com/BelgardHardscapes](https://www.youtube.com/BelgardHardscapes)



[Twitter.com/Belgard](https://twitter.com/Belgard)



[Instagram.com/BelgardOutdoorLiving](https://www.instagram.com/BelgardOutdoorLiving)